

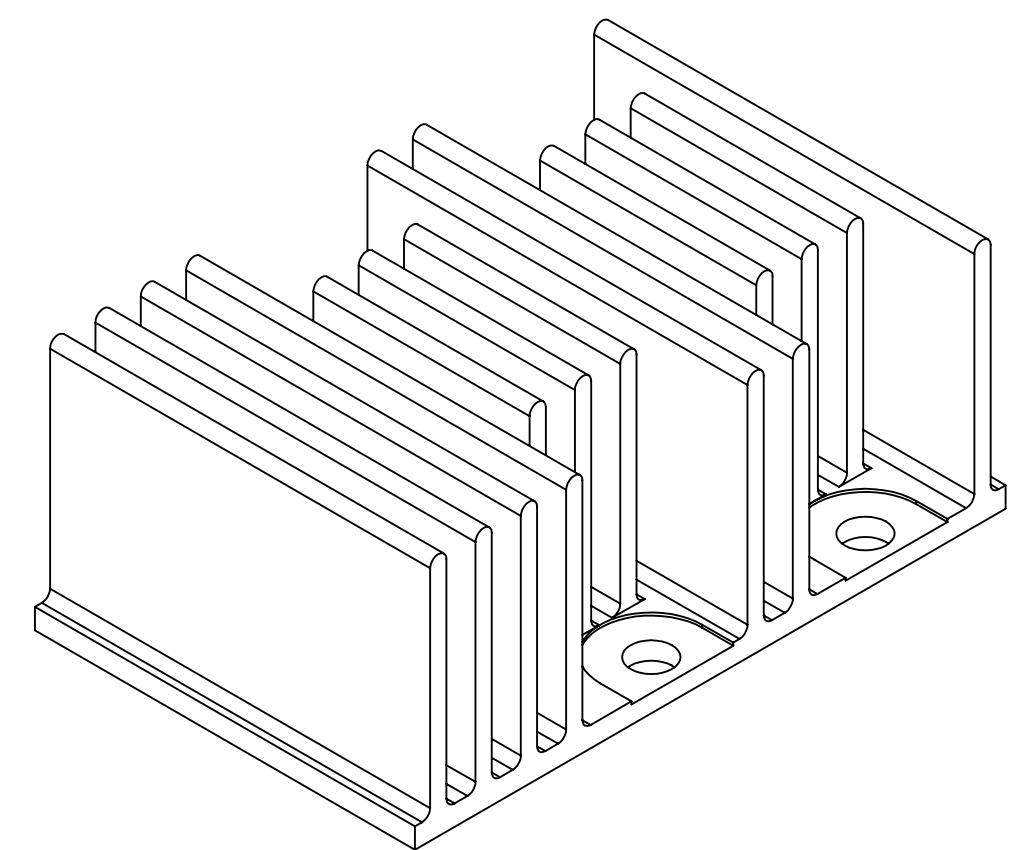

VICOR CONFIDENTIAL
 THIS DOCUMENT AND THE DATA DISCLOSED HEREIN OR HEREWITH IS NOT TO BE REPRODUCED, USED OR DISCLOSED IN WHOLE OR IN PART TO ANYONE WITHOUT THE PERMISSION OF VICOR CORP.

REV.	DESCRIPTION	INTL	DATE	APVD
1	RELEASE PER E161031b	GCK	11/22/16	RH

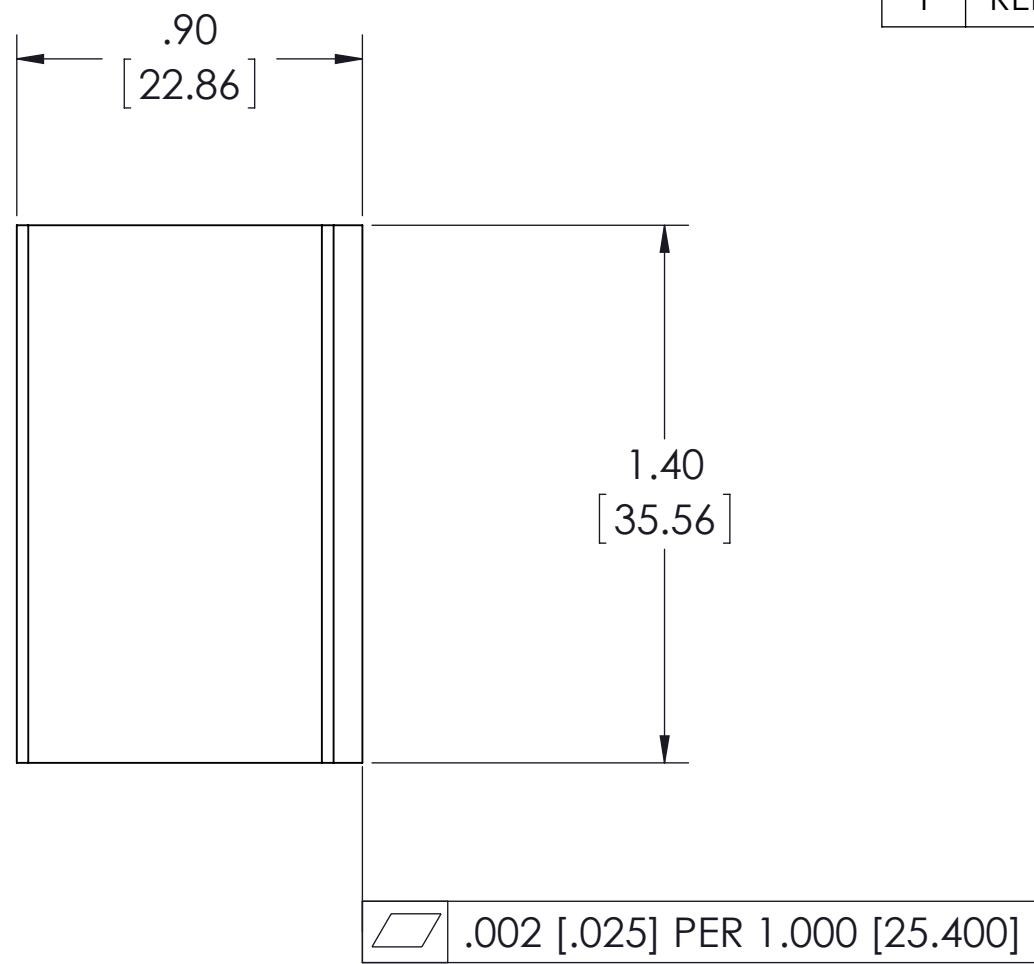
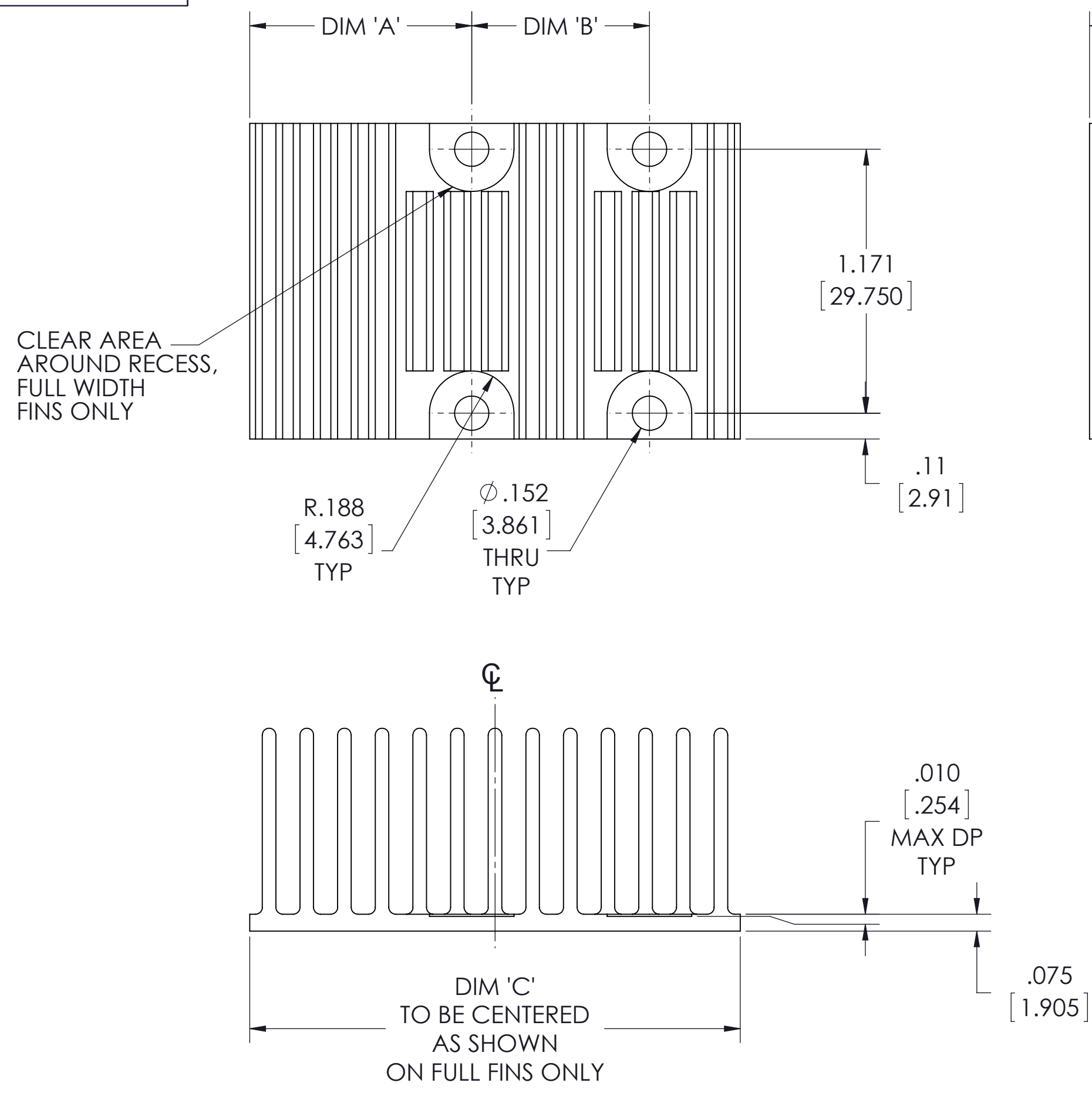

- NOTES:
- CLEAR FINISH, RoHS COMPLIANT PER CST-0001, LATEST REVISION PER
 A.) CHROMIUM FREE, OR
 B.) TRIVALENT CHROMIUM IN ACCORDANCE WITH MIL-DTL-5541, TYPE II, CLASS 1A OR 3. SEE CST-0003 FOR TYPES OF AVAILABLE FINISHES.
 - SEE CHART FOR BOM NUMBERS
 SEE BOMS FOR PARTS LIST.
 - MATERIAL: MAKE FROM AAVID EXTRUSION P/N 74765 OR EQUIVALENT (VICOR P/N 42596)
 - REMOVE ALL BURRS AND SHARP EDGES

BOM NUMBER	PRODUCT	DIM 'A'	DIM 'B'	DIM 'C'
43808-01	2214 (0 STAGE) 2223	0.57 [14.55]	N/A	1.23 [31.16]
43808-02	2814 (1 STAGE) 2223	0.95 [24.22]	N/A	1.60 [40.69]
43808-03	2814 (0 STAGE) 3623	0.57 [14.55]	0.789 [20.033]	1.77 [45.04]
43808-04	3414 (1 STAGE) 3623	0.98 [25.00]	0.789 [20.033]	2.18 [55.25]
43808-05	3714 (1 STAGE) 4623	0.98 [25.00]	1.150 [29.200]	2.55 [64.65]
43808-06	3814 (0 STAGE) 2361	0.39 [10.03]	1.277 [32.430]	2.56 [65.11]
43808-07	3814 (0 STAGE) 2361 NBM	0.39 [10.03]	1.277 [32.430]	2.56 [65.11]
43808-08	4414 (1 STAGE) 2361	0.98 [25.00]	1.277 [32.430]	3.15 [80.07]
43808-09	4414 (1 STAGE) 6123	0.98 [25.00]	1.757 [44.625]	3.15 [80.07]
43808-10	4914 (2 STAGE) 6123	1.38 [34.95]	1.757 [44.625]	3.54 [89.88]
43808-11	5314 (0 STAGE) 2392	0.54 [13.84]	2.490 [63.250]	3.93 [99.77]
43808-12	5314 (0 STAGE) 9223	0.54 [13.84]	2.970 [75.445]	3.93 [99.77]
43808-13	5614 (1 STAGE) 2392	0.98 [25.00]	2.490 [63.250]	4.24 [107.57]
43808-14	5614 (1 STAGE) 9223	0.98 [25.00]	2.970 [75.445]	4.24 [107.57]
43808-15	6114 (2 STAGE) 9223	TBD	TBD	TBD

DRAWN BY Matthew Biron	DATE 2/25/2016	VICOR		SWD
UNLESS OTHERWISE SPECIFIED DIMENSIONS ARE : INCH / [MM]		DWG HEAT SINK XF .900 TALL ADAPTERS		
TOLERANCES ARE: DECIMALS ±0.01 [0.25] ANGLES ±1° X.XXX [X.XXX] = ±0.005 [0.127]		SIZE C	CAGE CODE 67131	DWG NO 43756
THIRD ANGLE PROJECTION 		SCALE 2:1	REV 1	SHEET 1 OF 1