

UNCONTROLLED DOCUMENT

SC:0.50	PART NUMBER	REV.
	SSA-LXB10G6Y3I1W	A
REV.	E.C.N. NUMBER AND REVISION COMMENTS	DATE
A	E.C.N. #11148	5.22.07

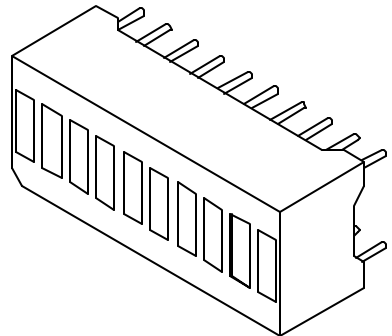

TOP VIEW POLARITY

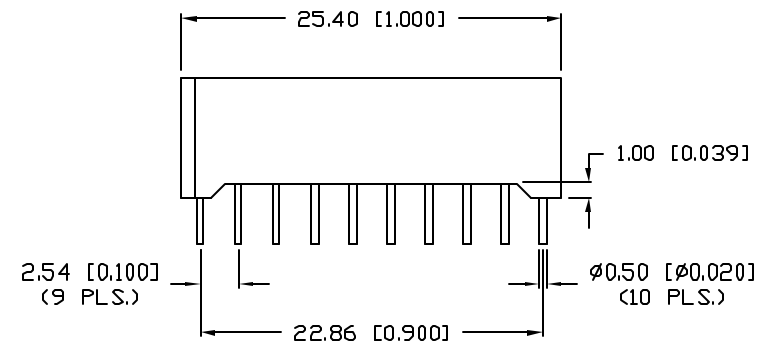
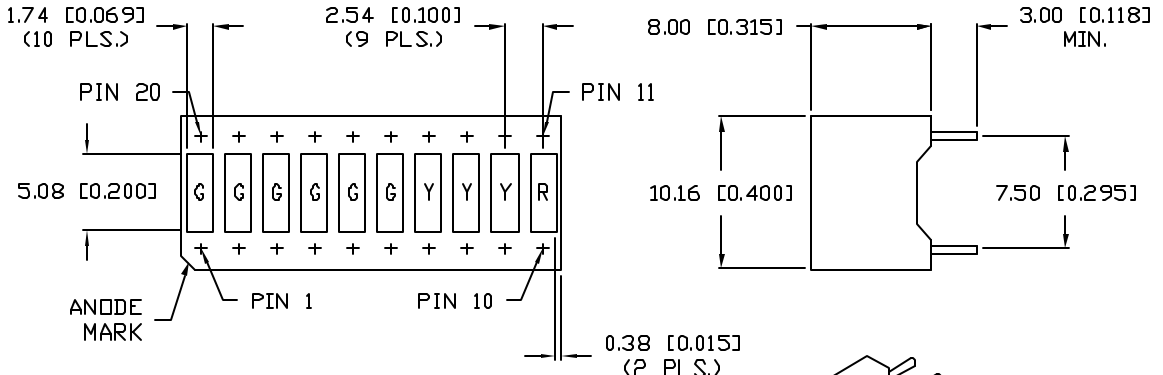
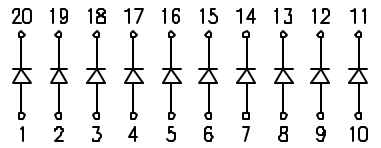

UNDER REVISION

ELECTRO-OPTICAL CHARACTERISTICS $T_A=25^\circ\text{C}$ $I_f=20\text{mA}$

PARAMETER	GREEN	YELLOW	RED	UNITS	TEST COND
PEAK WAVELENGTH	565	585	635	nm	
FORWARD VOLTAGE (TYP.)	2.2	2.1	2.0	nm	
FORWARD VOLTAGE (MAX.)	2.6	2.5	2.5	V _f	
REVERSE VOLTAGE	5.0	5.0	5.0	V _r	I _r =100µA
AXIAL INTENSITY	8	8	8	mcd	I _f =20mA
VIEWING ANGLE	160	160	160	2x theta	
LED POSITION:	1~6	7~9	10		
EPOXY LENS FINISH:	MILKY WHITE DIFFUSED				
FACE COLOR:	GRAY				

LIMITS OF SAFE OPERATION AT 25°C PER CHIP

PARAMETER	COLORS	MAX	UNITS
PEAK FORWARD CURRENT*		150	mA
STEADY CURRENT	(G/Y/R)	25/30/30	mA
POWER DISSIPATION		105	mW
DERATE FROM 25°C		-1.2	mW/°C
OPERATING, STORAGE TEMP.		-40 TO +85	°C
SOLDERING TEMP.		+260	°C
2.0mm FROM BODY			3 SEC. MAX

* t<10µS

*UNLESS OTHERWISE SPECIFIED TOLERANCES PER DECIMAL PRECISION ARE: X=±1 (±0.039), X.X=±0.5 (±0.020), X.XX=±0.25 (±0.010), X.XXX=±0.127 (±0.005). LEAD SIZE=±0.05 (±0.002), LEAD LENGTH=±0.75 (±0.030), MIN.=^{+0.00}_{-0.00} DECIMAL PRECISION MAX.=^{+0.00}_{-0.00} DECIMAL PRECISION

REV.	PART NUMBER
A	SSA-LXB10G6Y3I1W

CONFIDENTIAL INFORMATION
 THE INFORMATION CONTAINED IN THIS DOCUMENT IS THE PROPERTY OF LUMEX INC. EXCEPT AS SPECIFICALLY AUTHORIZED IN WRITING BY LUMEX INC, THE HOLDER OF THIS DOCUMENT SHALL KEEP ALL INFORMATION CONTAINED HEREIN CONFIDENTIAL AND SHALL PROTECT SAME IN WHOLE OR IN PART FROM DISCLOSURE AND DISSEMINATION TO ALL THIRD PARTIES.



290 E. HELEN ROAD
 PALATINE, IL 60067-6976
 PHONE: +1.847.359.2790
 US WEB: www.lumex.com
 TW WEB: www.lumex.com.tw

10 SEGMENT RECTANGULAR BAR GRAPH,
 6 GREEN, 3 YELLOW, 1 RED, MILKY WHITE DIFFUSED.

RELIABILITY NOTE
 OUR MANY YEARS OF EXPERIENCE DATA ACCUMULATION INDICATE THAT SOLDER HEAT IS A MAJOR CAUSE OF EARLY AND FUTURE FAILURE. PLEASE PAY ATTENTION TO YOUR SOLDERING PROCESS.

DRAWN BY:	CHECKED BY:	APPROVED BY:	DATE:
JN			8.5.02
			PAGE: 1 OF 1
			SCALE: N/A



UNCONTROLLED DOCUMENT