

UNCONTROLLED DOCUMENT

CAUTION: PRESSURE SENSITIVE ASSEMBLY  
AVOID APPLYING PRESSURE TO LED  
DURING PANEL ASSEMBLY.

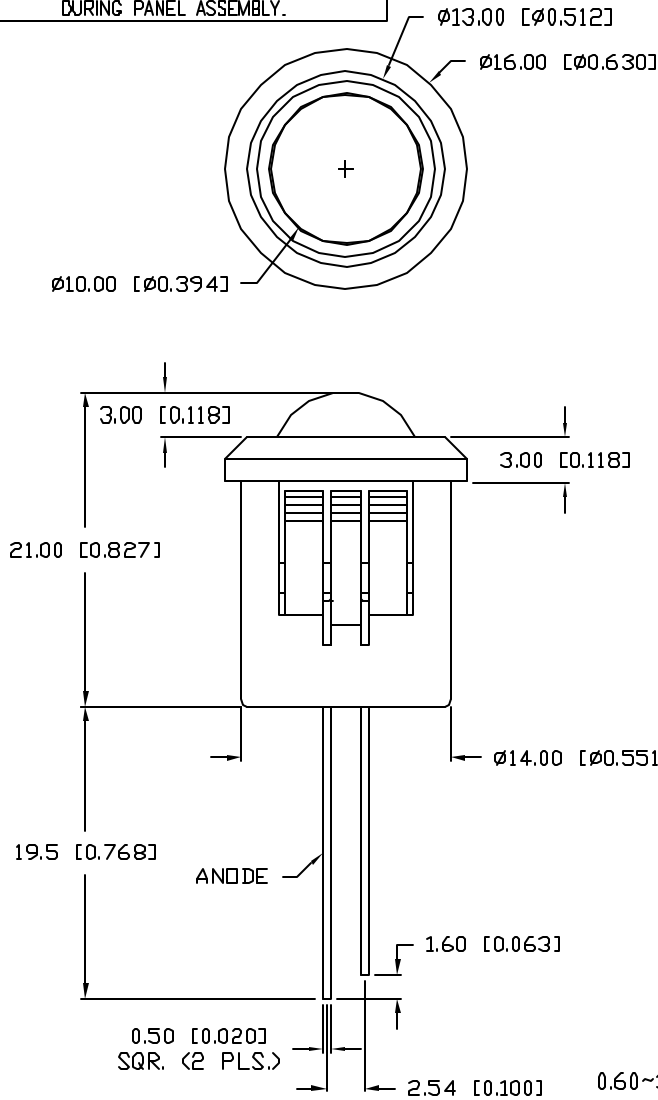

PART NUMBER		REV.
SSI-LXH1090BID		C
REV.	E.C.N. NUMBER AND REVISION COMMENTS	DATE
A	E.C.N. #10BRDR.	10.9.97
B	E.C.N. #10539.	9.24.99
C	E.C.N. #10BRDR. & REDRAWN IN 3D.	1.5.02

ELECTRO-OPTICAL CHARACTERISTICS  $T_A=25^\circ\text{C}$

PARAMETER	MIN	TYP	MAX	UNITS	TEST COND
PEAK WAVELENGTH		635		nm	
FORWARD VOLTAGE	3.0	9-12	13.0	$V_f$	
BLINKING FREQUENCY:		1.5		Hz	$V_f=9.0$ , $I_f=70\text{mA}$
		2.5		Hz	$V_f=3.0$ , $I_f=6\text{mA}$
AXIAL INTENSITY		50		mcd	$V_f=9.0$
VIEWING ANGLE		60		2x theta	
EMITTED COLOR:	RED				
EPOXY LENS FINISH:	RED DIFFUSED				

LIMITS OF SAFE OPERATION AT  $25^\circ\text{C}$

PARAMETER	MAX	UNITS
PEAK FORWARD CURRENT*	70	mA
STEADY CURRENT	38-56	mA
POWER DISSIPATION	200	mW
DERATE FROM $25^\circ\text{C}$	-1.2	mW/ $^\circ\text{C}$
OPERATING, STORAGE TEMP.	-40 TO +85	$^\circ\text{C}$
SOLDERING TEMP.	+260	$^\circ\text{C}$
2.0mm FROM BODY		3 SEC. MAX

\*  $t < 10\mu\text{s}$

NOTES:

- SSL-LX100133BID LED.
- SSH-RTF1090 HOLDER.
- UV EPOXY TO RETAIN LED IN HOLDER.

UNCONTROLLED DOCUMENT

\*UNLESS OTHERWISE SPECIFIED TOLERANCES PER DECIMAL PRECISION ARE: X= $\pm 1$  ( $\pm 0.039$ ), X.X= $\pm 0.5$  ( $\pm 0.020$ ), X.XX= $\pm 0.25$  ( $\pm 0.010$ ), X.XXX= $\pm 0.127$  ( $\pm 0.005$ ). LEAD SIZE= $\pm 0.05$  ( $\pm 0.002$ ), LEAD LENGTH= $\pm 0.75$  ( $\pm 0.030$ ), MIN.= $\frac{+0.00}{-0.00}$  DECIMAL PRECISION MAX.= $\frac{+0.00}{-0.00}$  DECIMAL PRECISION

REV.	PART NUMBER
C	SSI-LXH1090BID

CONFIDENTIAL INFORMATION  
THE INFORMATION CONTAINED IN THIS DOCUMENT IS THE PROPERTY OF LUMEX INC. EXCEPT AS SPECIFICALLY AUTHORIZED IN WRITING BY LUMEX INC, THE HOLDER OF THIS DOCUMENT SHALL KEEP ALL INFORMATION CONTAINED HEREIN CONFIDENTIAL AND SHALL PROTECT SAME IN WHOLE OR IN PART FROM DISCLOSURE AND DISSEMINATION TO ALL THIRD PARTIES.



290 E. HELEN ROAD  
PALATINE, IL 60067-6976  
PHONE: +1.847.359.2790  
US WEB: www.lumex.com  
TW WEB: www.lumex.com.tw

T-10mm 635nm BLINKING RED LED PANEL INDICATOR,  
RED DIFFUSED LENS.

RELIABILITY NOTE  
OUR MANY YEARS OF EXPERIENCE DATA ACCUMULATION INDICATE THAT SOLDER HEAT IS A MAJOR CAUSE OF EARLY AND FUTURE FAILURE. PLEASE PAY ATTENTION TO YOUR SOLDERING PROCESS.

DRAWN BY:	CHECKED BY:	APPROVED BY:	DATE: 7.14.93
BC			PAGE: 1 OF 1
			SCALE: N/A