

AVERY DENNISON MARKETING SPECIFICATION

HISTORY

THE SUBJECT MATTER DISCLOSED HEREIN EMBODIES PROPRIETARY INFORMATION WHICH IS THE CONFIDENTIAL PROPERTY OF THE AVERY DENNISON CO. NONE OF WHICH SHALL BE COPIED, REPRODUCED, DISCLOSED TO OTHERS, PUBLISHED OR USED IN WHOLE OR IN PART, FOR ANY PURPOSE OTHER THAN THAT FOR WHICH IT IS BEING MADE AVAILABLE WITHOUT THE EXPRESS ADVANCE WRITTEN PERMISSION OF A DULY AUTHORIZED AGENT OF THE COMPANY. THIS DOCUMENT IS THE PROPERTY OF THE AVERY DENNISON CO. AND IS TO BE RETURNED TO THE COMPANY ON DEMAND.

| REV. | DATE | DESCRIPTION |
|------|----------|--|
| L | 10.29.14 | REDRAWN IN NEW FORMAT, ADDED UL INFORMATION AND LOGO |

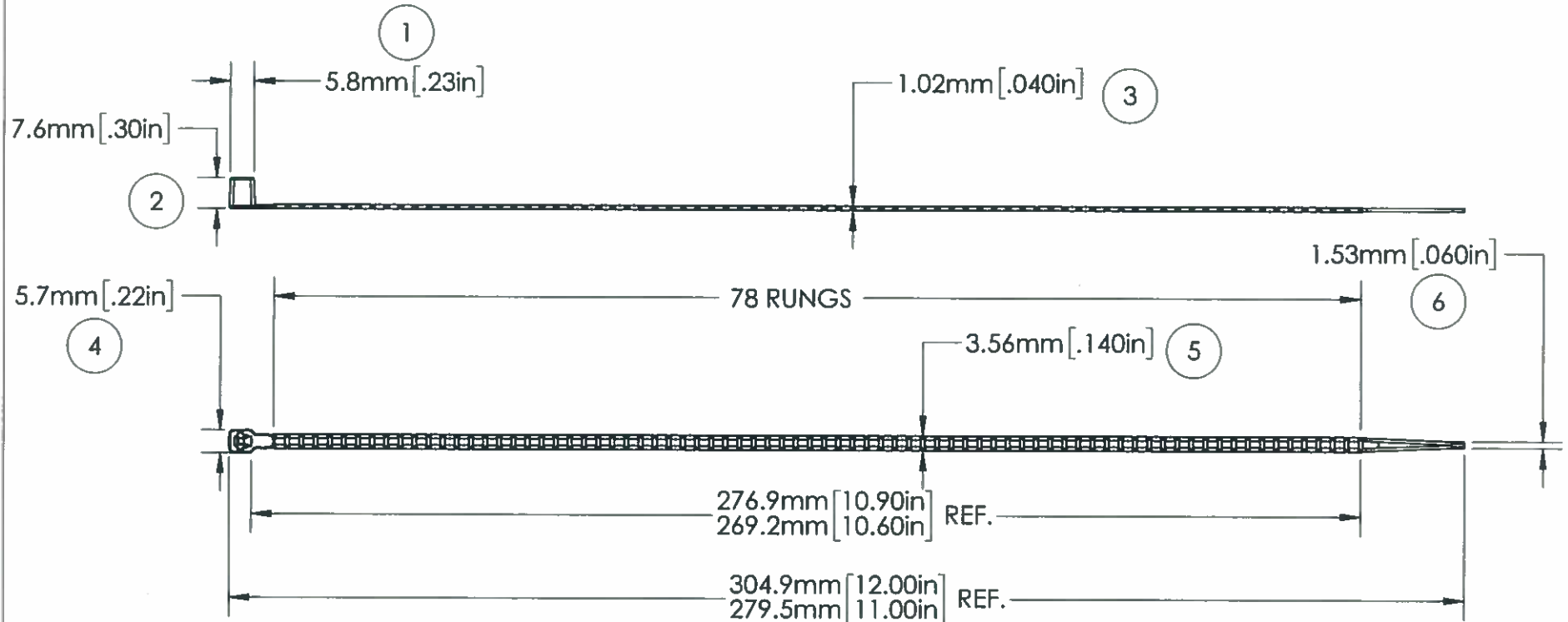

NOTE: THESE CABLE TIES ARE PLENUM RATED AND HAVE A FLAMMABILITY RATING OF V-2



LISTED

POSITIONING DEVICE
E57800
TYPE 21

| | | | | | |
|-------------------------|---|---------------------------------|-----------------------------|---------------------------|--|
| LOOP TENSILE STRENGTH: | 40 LBF/180 N MIN. PER AS-23190 | APPROVALS: | ENG. APPR. | <i>Millal</i> 7/26/2017 | AVERY DENNISON <small>FASTENER DIVISION FRIBURG, MA 01420 U.S.A. TEL. 1-800-225-5913 FAX. 978-353-8157</small> |
| OPERATING TEMP RANGE: | -40°F (-40°C) TO 185°F (85°C) | | Q.A. APPR. | <i>J. Boyle</i> 7/24/2017 | |
| MIN. INSTALLATION TEMP: | 32°F (0°C) | | | | |
| WEIGHT: | 0.72 g. / (0.02448 oz.) | SPECIFIED TOLERANCES ARE: | MATERIAL | NYLON 6/6 | DESCRIPTION |
| BUNDLE DIAMETER: | ∅ 1.6mm TO ∅ 76.2mm (0.06" - 3.0") | | .XX ± .03 INCHES .X ± .7 MM | COLOR | |
| TOOL: | 12001-0 - HAND TOOL 12500-0 - PNEUMATIC TOOL | .XXX ± .010 INCHES .XX ± .25 MM | | | REV. |
| PACKAGING: | 100/BAG, 5000/CASE | ANGULAR: ± 2° | | | L |

5 4 3 2 1