

4

3

2

1

THIS DRAWING IS UNPUBLISHED. RELEASED FOR PUBLICATION. ALL RIGHTS RESERVED.

REVISIONS					
P	LTR	DESCRIPTION	DATE	DWN	APVD
	F2	REVISED PER ECO-11-004917	11MAR11	RK	HMR
	F3	REVISED PER ECO-16-017354	07MAR2017	RK	AS

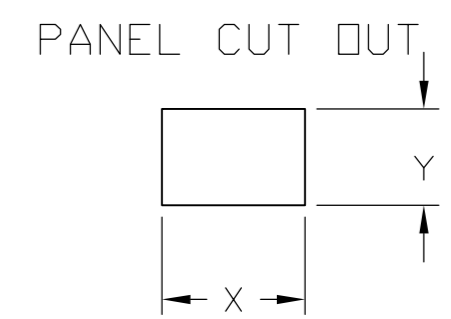
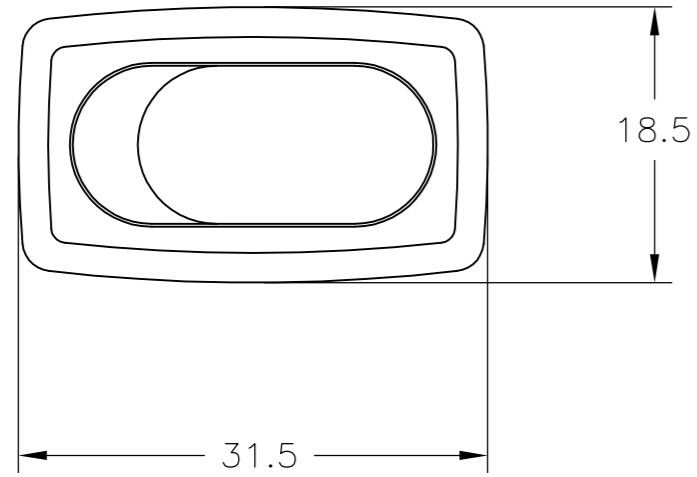

4.00-5.00	28.0-0.1	13.8+0.1
3.00-4.00	27.8-0.1	13.8+0.1
0.75-3.00	27.6-0.1	13.8+0.1
PANEL THICKNESS	X	Y

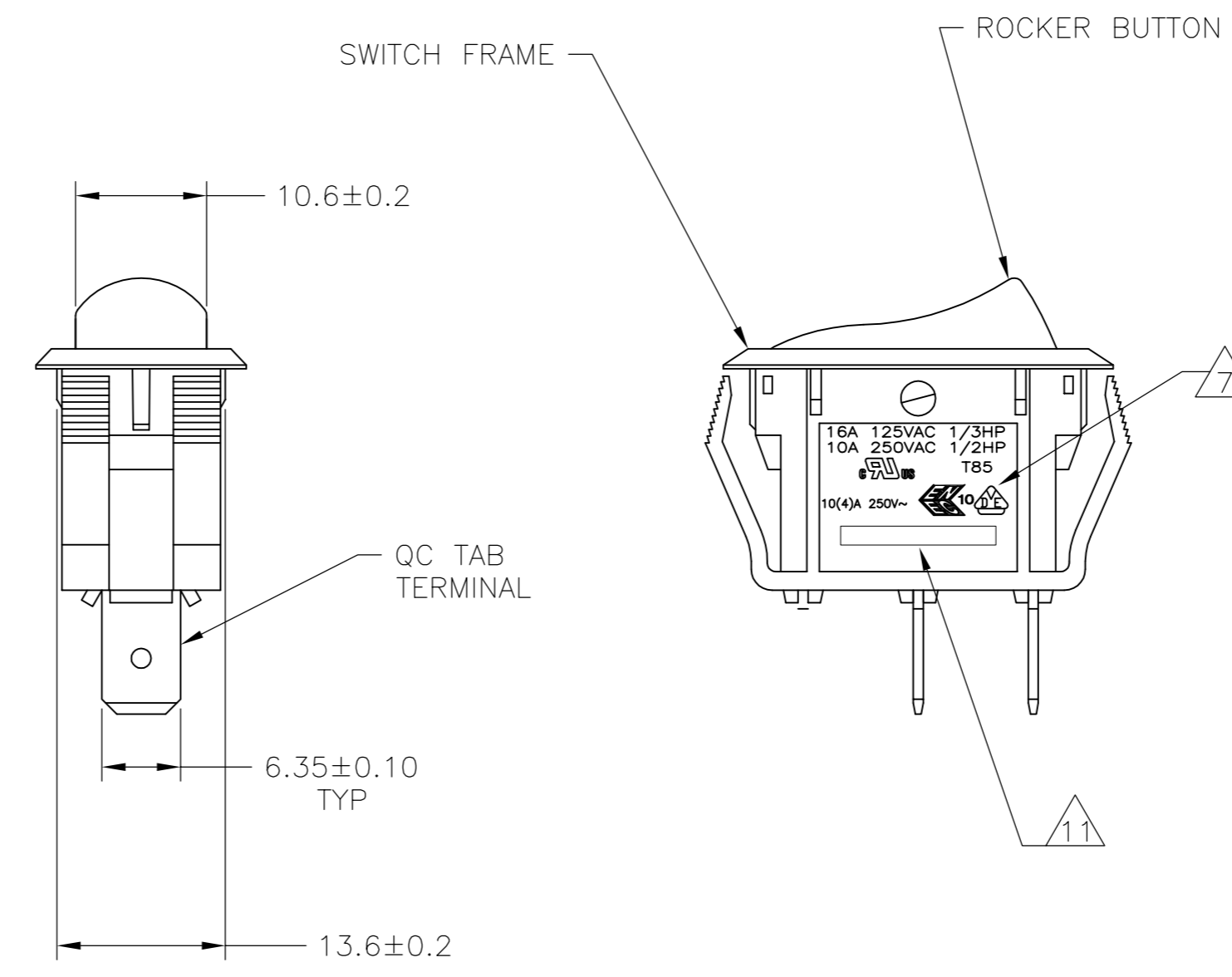
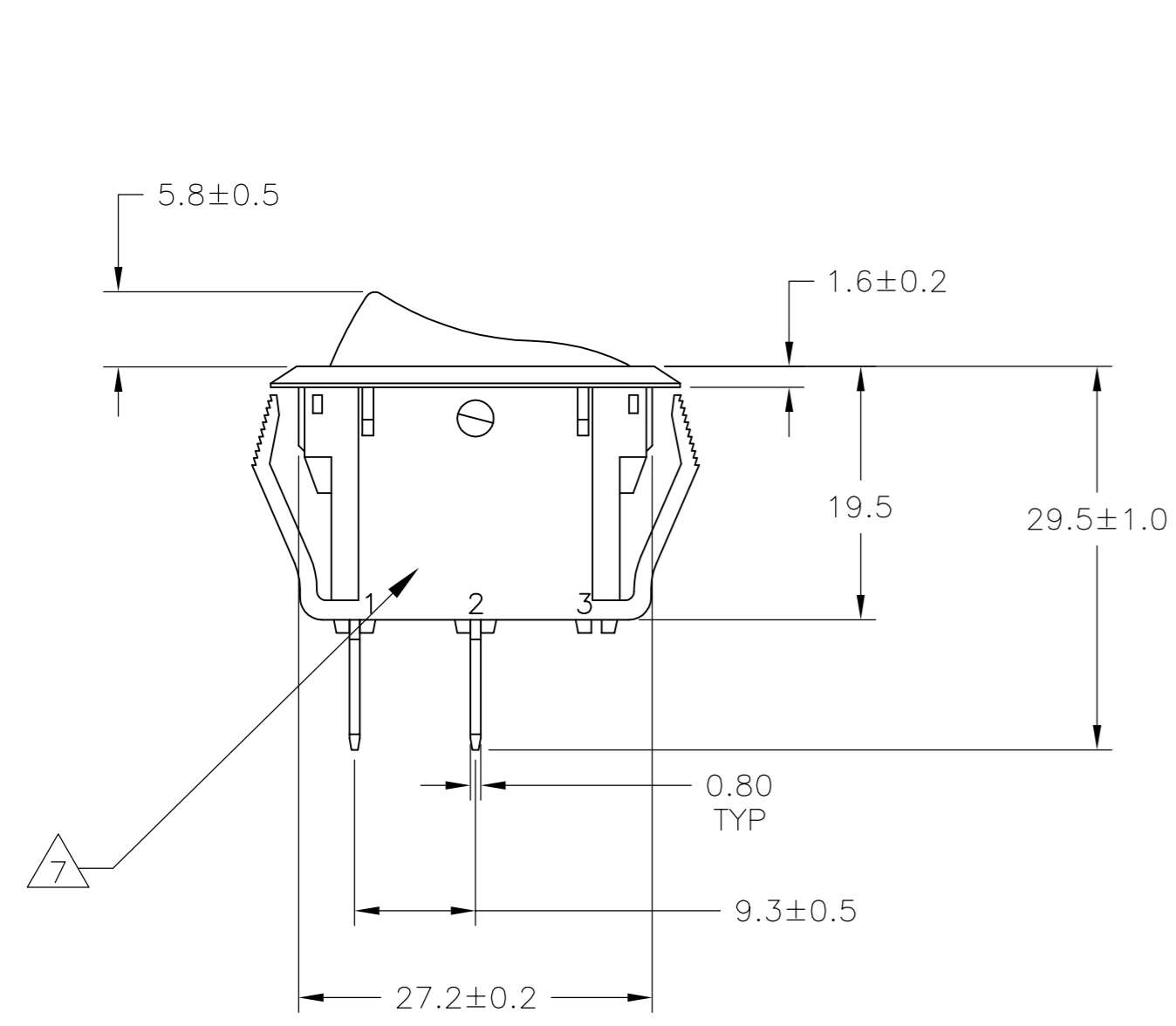

SWITCH FUNCTION A1
CIRCUIT DIAGRAM

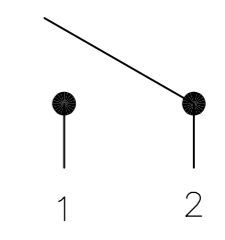

1571091-1 SHOWN

THIS DRAWING IS A CONTROLLED DOCUMENT.		DWN: BSV	01APRO4	TE TE Connectivity	
DIMENSIONS: mm		CHK: J.MOSIER	APVD: JP		
TOLERANCES UNLESS OTHERWISE SPECIFIED:		PRODUCT SPEC		POWER ROCKER SWITCH 13.8mmX27.6mm	
0 PLC ± -		APPLICATION SPEC		PANEL SIZE SPST, 2 TERMINALS, NON-ILLUMINATED	
1 PLC ± 0.30		MATERIAL		SIZE: A2	CAGE CODE: 00779
2 PLC ± 0.05		FINISH		DRAWING NO: 1571091	RESTRICTED TO: -
3 PLC ± -		WEIGHT		SCALE: 1:1	SHEET: 1 of 3
4 PLC ± -		CUSTOMER DRAWING		REV: F3	
ANGLES ± -					

4

3

2

1

THIS DRAWING IS UNPUBLISHED. RELEASED FOR PUBLICATION. ALL RIGHTS RESERVED.

REVISIONS					
P	LTR	DESCRIPTION	DATE	DWN	APVD
-	-	SEE SHEET 1	-	-	-

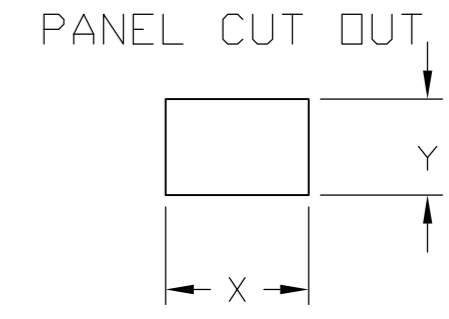
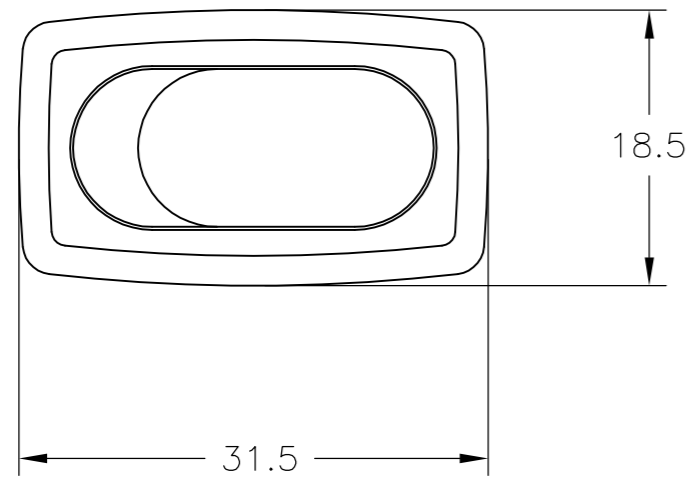

4.00-5.00	28.0-0.1	13.8+0.1
3.00-4.00	27.8-0.1	13.8+0.1
0.75-3.00	27.6-0.1	13.8+0.1
PANEL THICKNESS	X	Y

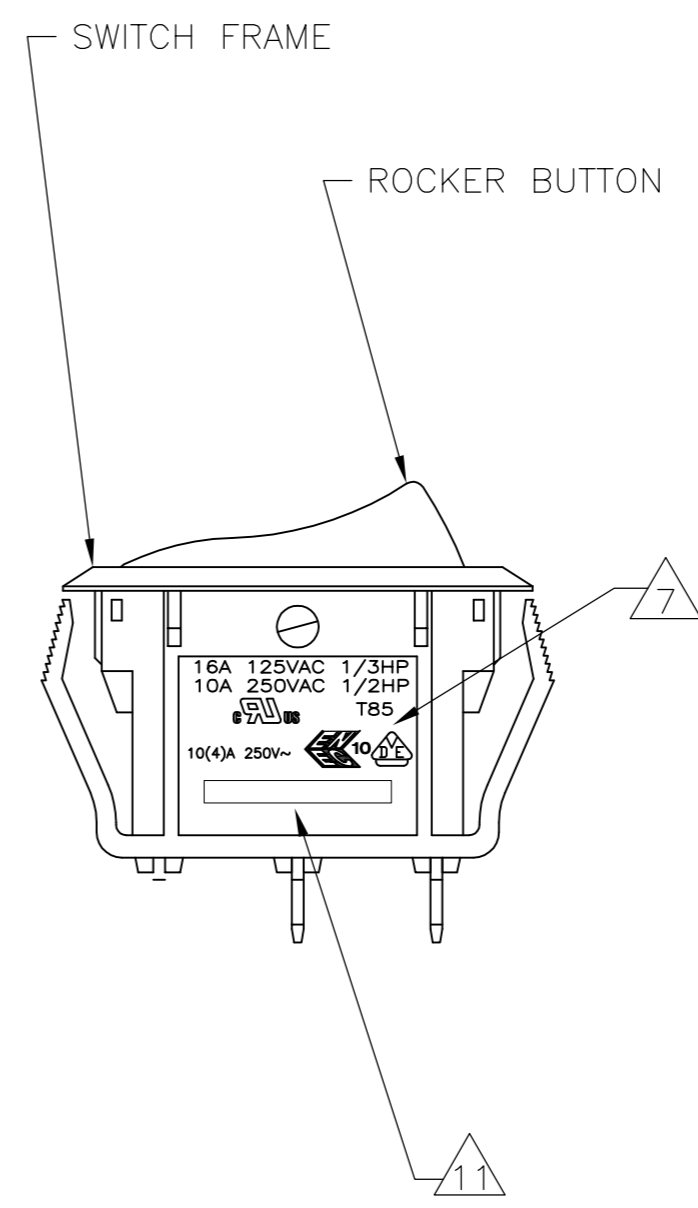
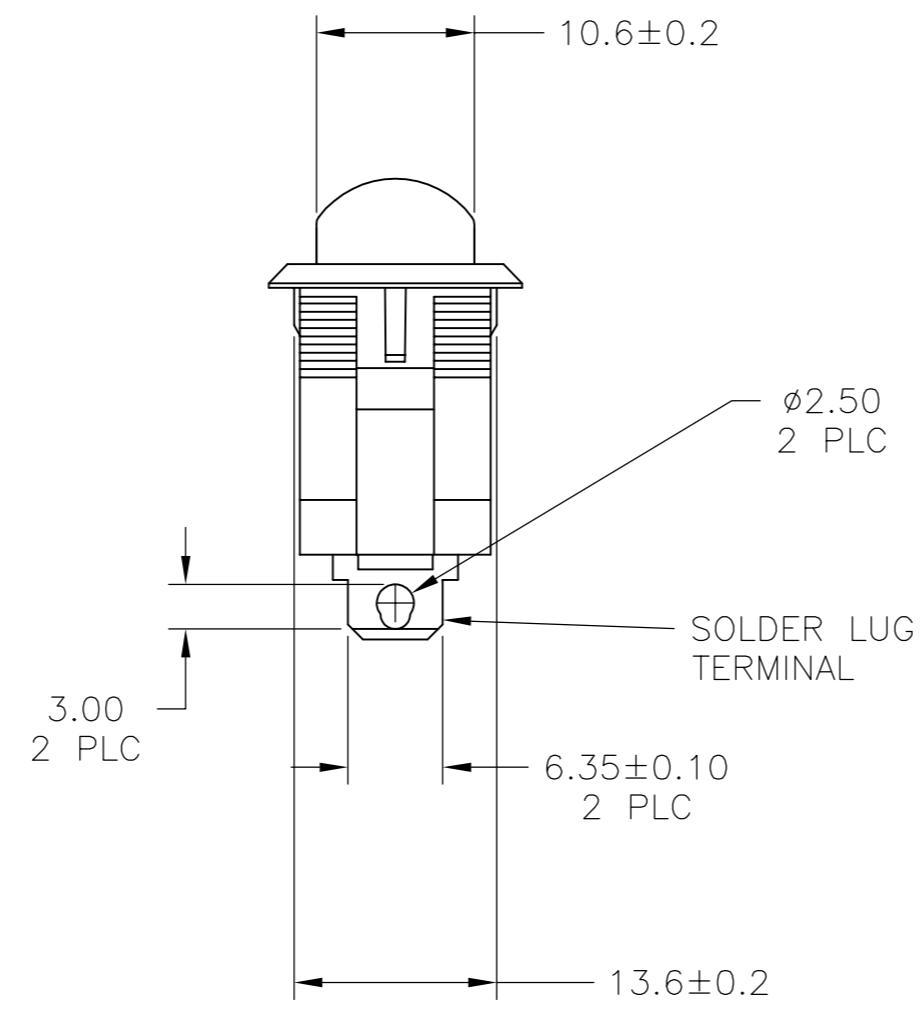
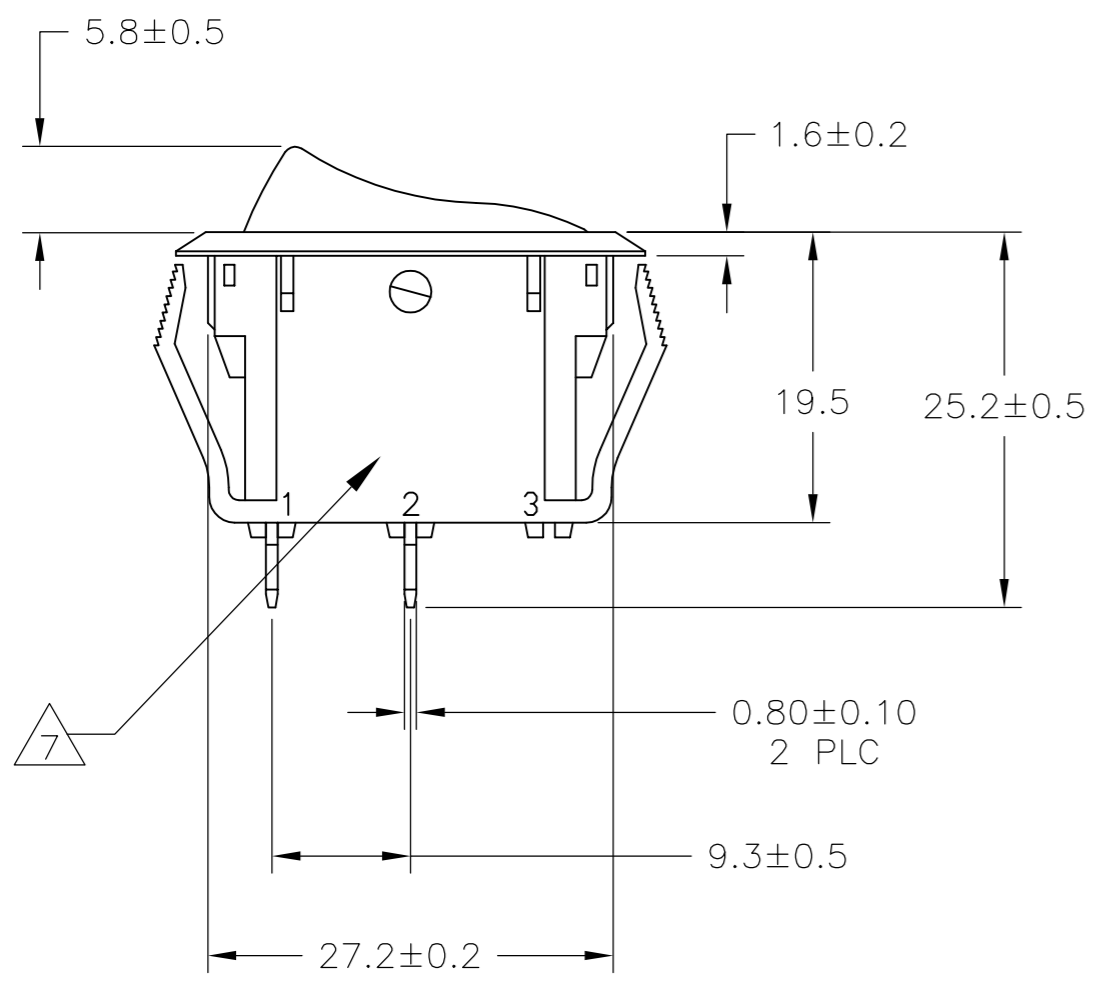

SWITCH FUNCTION A1
CIRCUIT DIAGRAM

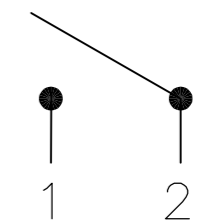

1571091-4 SHOWN

THIS DRAWING IS A CONTROLLED DOCUMENT.		DWN: BSV	01APRO4	TE TE Connectivity	
DIMENSIONS: mm		CHK: J.MOSIER	APVD: JP		
TOLERANCES UNLESS OTHERWISE SPECIFIED:		PRODUCT SPEC		POWER ROCKER SWITCH 13.8mmX27.6mm	
0 PLC ± -		APPLICATION SPEC		PANEL SIZE SPST, 2 TERMINALS, NON-ILLUMINATED	
1 PLC ± 0.30		MATERIAL		SIZE: A2	CAGE CODE: 00779
2 PLC ± 0.05		FINISH		DRAWING NO: 1571091	RESTRICTED TO: -
3 PLC ± -		WEIGHT: 0		SCALE: 1:1	SHEET: 2 of 3
4 PLC ± -		CUSTOMER DRAWING		REV: F3	
ANGLES ± -					

THIS DRAWING IS UNPUBLISHED. RELEASED FOR PUBLICATION
 © COPYRIGHT - By - ALL RIGHTS RESERVED.

REVISIONS				
P	LTR	DESCRIPTION	DATE	APVD
-	-	SEE SHEET 1	-	-

LEGACY PART NUMBER

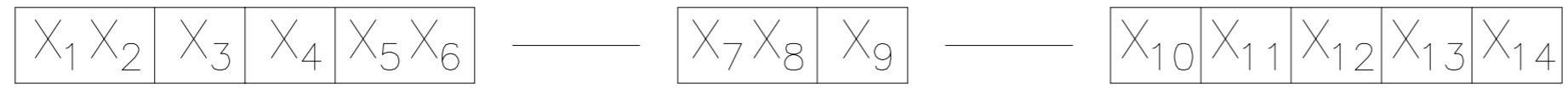

SWITCH TYPE: X₁X₂ = PR - POWER ROCKER
 NOMINAL PANEL CUT OUT SIZE: X₃ = B - 13.8x27.6
 NUMBER OF POLES: X₄ = S - SINGLE
 SWITCH FUNCTION: X₅X₆ = A1 - ON-OFF, WITH OPAQUE SINGLE-COLOR ROCKER BUTTON.

SECONDARY ROCKER COLOR: X₁₂ = Ø - NOT APPLICABLE

CURRENT RATING: X₇X₈ = 16 - △6
 TERMINAL TYPE: X₉ = F - QC TAB
L - SOLDER LUG
 FRAME COLOR: X₁₀ = B - BLACK
W - WHITE

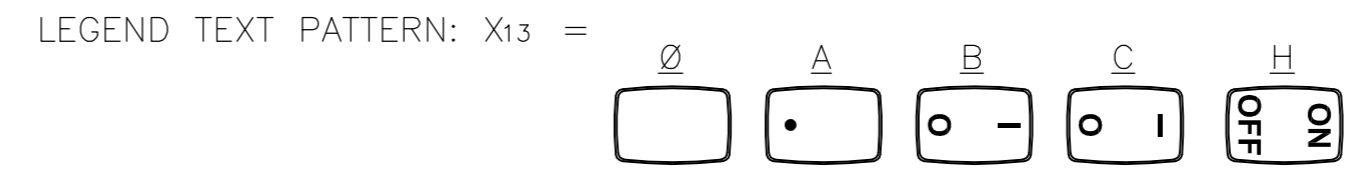

ROCKER COLOR: X₁₁ = B - BLACK
G - GREEN
R - RED
W - WHITE

LEGEND TEXT COLOR: X₁₄ = Ø - NOT APPLICABLE
G - GREEN
R - RED
B - BLACK
W - WHITE

1

MATERIALS:
 ROCKER BUTTON & HOUSING: NYLON 66, UL 94 V-2.
 TERMINAL, ACTIVE CONTACTOR: COPPER ALLOY PER ASTM B152/B152M
 PLUNGER: COPPER ALLOY PER ASTM B036
 SPRING: STEEL WIRE PER ASTM A228/A228M
 CONTACT: SILVER-TIN OXIDE

2

FINISH:
 ACTIVE CONTACTOR & TERMINALS: 1.0µm MIN SILVER
 PLUNGER: 3.0µm MIN NICKEL

3.

ELECTRICAL SPECIFICATIONS: △6
 CURRENT & VOLTAGE
 CONTACT RESISTANCE (INITIAL): <50mΩ
 DIELECTRIC STRENGTH (INITIAL): >1000 VAC, 1 MINUTE
 INSULATION RESISTANCE (INITIAL): >100MΩ MIN (500VDC BETWEEN OPEN CONTACTS)
 INRUSH CURRENT: 50A / 3msec (CAPACITIVE LOAD)
 ELECTRICAL LIFE ENDURANCE: >6000 OPERATIONS,
 TEMPERATURE RISE AT TERMINALS: <30°C, 6000 OPERATIONS
 (AMBIENT CONDITIONS: 25±2°C AND 65±5%R.H)

5.

ENVIRONMENTAL SPECIFICATIONS:
 AMBIENT TEMPERATURE: -20°C TO +85°C
 HUMIDITY: MAX 85%
 SALT SPRAY: NO REMAKABLE RUST IN METAL PARTS. (5%SALT / 35°C 24HRS)
 SHOCK: NO MECHANICAL DEFECT OR DAMAGE. (100g / 10MSEC/ X,Y,Z 3 TIMES)
 VIBRATION: NO MECHANICAL DEFECT OR DAMAGE. (10-55Hz /1.5mm/ X,Y,Z 2HRS)

6

UL: 16A@125VAC 1/3HP / 10A@250VAC 1/2HP
 ENEC: 10(4)A 250V~

7

ELECTRICAL RATINGS, APPROVED AGENCY LOGOS, TERMINAL IDENTIFICATION NUMBERS, MOLDED APPROXIMATELY AS SHOWN ON THE SIDES OF THE SWITCH HOUSING.

8.

COMPONENT-RECOGNIZED TO US & CANADIAN STANDARDS
 UL FILE NO. E46765

9.

COMPONENT-RECOGNIZED TO EUROPEAN STANDARDS
 (ENEC & VDE) MARKS LICENSE NO 40020315

10.

ROHS 2002/95/EC COMPLIANT

11

TE CONNECTIVITY LOGO LOCATED APPROXIMATELY AS SHOWN

OBSOLETE	1	PRBSA1-16F-BROHW	6-1571091-0
	2	PRBSA1-16L-BR000	5-1571091-8
	1	PRBSA1-16F-BR000	5-1571091-7
	1	PRBSA1-16F-BW0HB	1-1571091-2
OBSOLETE	1	PRBSA1-16F-BW000	1-1571091-1
	1	PRBSA1-16F-BB0HW	1571091-9
	2	PRBSA1-16L-BB0CW	1571091-6
	2	PRBSA1-16L-BB0BW	1571091-5
	2	PRBSA1-16L-BB000	1571091-4
	1	PRBSA1-16F-BB0CW	1571091-3
	1	PRBSA1-16F-BB0BW	1571091-2
1	PRBSA1-16F-BB000	1571091-1	
SHEET REF.	LEGACY PART NUMBER	PART NUMBER	

4.

MECHANICAL SPECIFICATIONS:
 ACTUATING FORCE: 300g MIN, 700g MAX
 OPERATING LIFE ENDURANCE: >100,000 OPERATIONS
 TERMINAL STRENGTH : >2.5kg- SOLDER LUG
 >10.0kg- QC TAB

THIS DRAWING IS A CONTROLLED DOCUMENT. DWN: BSV 01APR04
 CHK: J.MOSIER
 APVD: JP
 PRODUCT SPEC: -
 APPLICATION SPEC: -
 MATERIAL: -
 FINISH: -
 WEIGHT: -
 CUSTOMER DRAWING

TE Connectivity
 POWER ROCKER SWITCH 13.8mmX27.6mm
 PANEL SIZE SPST, 2 TERMINALS, NON-ILLUMINATED

SIZE: A2 CAGE CODE: 00779 DRAWING NO: 1571091 RESTRICTED TO: -
 SCALE: 1:1 SHEET: 3 of 3 REV: F3