

### GENERAL DESCRIPTION

The **XRP7704** is a quad-output pulse-width modulated (PWM) step-down DC-DC controller with a built-in LDO for standby power and GPIOs. The device provides a complete power management solution in one IC and is fully programmable via the included I<sup>2</sup>C serial interface. Independent Digital Pulse Width Modulator (DPWM) channels regulate output voltages and provide all required protection functions such as current limiting and over-voltage protection.

Each output voltage can be programmed from 0.9V to 5.1V without the need of an external voltage divider. The wide range of the programmable DPWM switching frequency (from 300 KHz to 1.5 MHz) enables the user to optimize between efficiency and component size. Input voltage range is from 6.5V to 20V.

I<sup>2</sup>C bus interface is provided to program the IC as well as to communicate with the host for fault reporting and handling, power rail parameters monitoring, etc.

The device offers a complete solution for soft-start and soft-stop. The start-up delay and ramp of each PWM regulator can be independently controlled. The device can start up a pre-biased PWM channel without causing large negative inductor current.

### APPLICATIONS

- Computing: Servers, Storage Systems
- Consumer: Set-top box (STB), Game Systems
- Industrial: ATE, DC-DC converters, Video Processing
- Plasma Display Panel (PDP)
- Networking and Telecommunications Equipment

### KEY FEATURES

- Four switching buck (step-down) controllers each with internal FET drivers
- 6.5V to 20V input voltage range – no additional voltage rails required
- Output voltages programmable from 0.9V to 5.1V
- Up to 6 reconfigurable GPIO pins
- Fully programmable via I<sup>2</sup>C interface
- Independent Digital Pulse Width Modulator (DPWM) channels with five coefficient PID control
- High Integration: elimination of external circuits and components required for compensation, parameter adjustment and interface
- Programmable DPWM frequency range (300kHz to 1.5 MHz) enables efficiency and component size optimization
- Complete power monitoring and reporting
- Independently controlled start-up delay and ramp for each regulator, including soft start with a pre-biased load voltage
- Independently controlled soft-stop delay and ramp for each regulator with a programmable stop voltage
- Over-temperature protection (OTP) and Under Voltage Lockout (UVLO); per-channel over-current protection (OCP) and over-voltage protection (OVP)
- Built-in LDO (configurable to 3.3V or 5V) with over-current protection
- Non-volatile memory for system configuration
- Configuration development tools

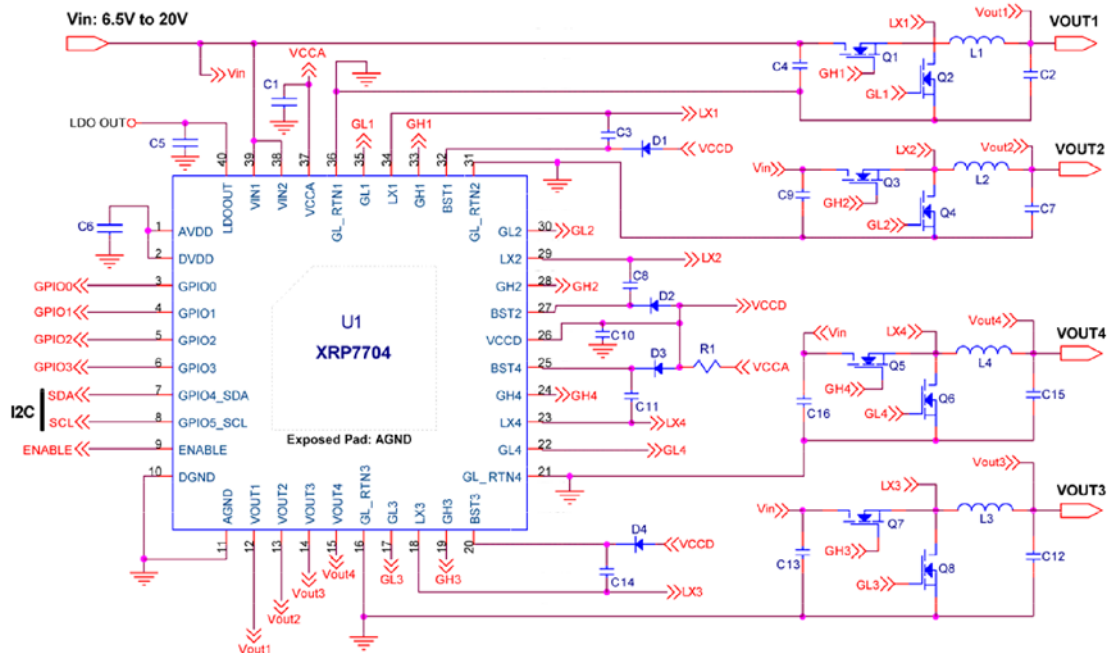



**ABSOLUTE MAXIMUM RATINGS**

These are stress ratings only and functional operation of the device at these ratings or any other above those indicated in the operation sections of the specifications below is not implied. Exposure to absolute maximum rating conditions for extended periods of time may affect reliability.

VCCA, VCCD, LDOOUT, GLx, VOUTx.....6V  
 AVDD, DVDD.....2.0V

VIN1, VIN2..... 22V  
 LXx..... -1V to 22V  
 Logic Inputs..... 6V  
 BSTx, GHx..... 27V  
 Storage Temperature..... -65°C to 150 °C  
 Thermal Resistance..... 18°C/W  
 Lead Temperature (Soldering, 10 sec).....300 °C

**ELECTRICAL SPECIFICATIONS**

Unless otherwise specified:  $T_A = T_J = 25^\circ\text{C}$ ,  $6.5 \leq \text{VIN1} \leq 20\text{V}$ ,  $6.5 \leq \text{VIN2} \leq 20\text{V}$ ,  $\text{ENABLE} = \text{HIGH}$ ,  $\text{C}_{\text{GL}} = \text{C}_{\text{GH}} = 1\text{nF}$ . Those specifications denoted by a ♦ are guaranteed over the full operating temperature range,  $-40^\circ\text{C} < T_J < 125^\circ\text{C}$ .

**QUIESCENT CURRENT**

PARAMETER	MIN	TYP	MAX	UNITS	CONDITIONS
VIN Supply Current in STANDBY		9		mA	LDOOUT enabled (no load) No switching converter channels enabled I2C Communication Active Switching Frequency = 400kHz
VIN Supply Current in SHUTDOWN		180		µA	EN = 0V VIN1 = VIN2 = 12V
VIN Supply Current		28		mA	4 channels running GH and GL = 1nF Load each VIN = 12V Switching Frequency = 300kHz
VIN Supply Current		50		mA	4 channels running GH and GL=1nF Load each VIN = 12V Switching Frequency = 1MHz

**BUCK CONTROLLERS**

PARAMETER	MIN	TYP	MAX	UNITS	CONDITIONS
VOUT Regulation Accuracy	-20		20	mV	♦ $0.9 \leq \text{VOUT} \leq 2.5\text{V}$
	-40		40	mV	♦ $2.6 \leq \text{VOUT} \leq 5.1\text{V}$
Feedback Resolution		5		mV	$0.9 \leq \text{VOUT} \leq 2.5\text{V}$
Feedback Resolution		10		mV	$2.6 \leq \text{VOUT} \leq 5.1\text{V}$
VOUT input voltage regulation range	0.9		5.1	V	♦ Programmable range of each channel.
VOUT set point resolution		50		mV	$0.9 \leq \text{VOUT} \leq 2.5\text{V}$
VOUT set point resolution		100		mV	$2.6 \leq \text{VOUT} \leq 5.1\text{V}$
VOUT Input Current			1	µA	♦ $0.9 < \text{VOUT} \leq 2.5\text{V}$
VOUT Input Resistance		120		kΩ	$2.6 \leq \text{VOUT} \leq 5.1\text{V}$



**LOW DROP-OUT REGULATOR**

PARAMETER	MIN	TYP	MAX	UNITS		CONDITIONS
LDOOUT Output Voltage (LDO=LOW)	3.15	3.3	3.45	V	◆	$6.5 \leq VIN_1 \leq 20V$ $0mA < I_{LDOOUT} < 100mA$
LDOOUT Output Voltage (LDO=HIGH)	4.75	5.0	5.25	V	◆	$6.5 \leq VIN_1 \leq 20V$ $0mA < I_{LDOOUT} < 100mA$
LDOOUT Short Circuit Current Limit	110		220	mA	◆	$V_{LDOOUT} = 0V$

**AUXILIARY ADCs**

PARAMETER	MIN	TYP	MAX	UNITS		CONDITIONS
ADC Resolution		8		bit		
Linearity Error Integral			2	LSB		
Linearity Error Differential	-1		1	LSB		
Input Dynamic Range VIN1	6.5		20	V	◆	
Input Dynamic Range VIN2	6.5		20	V	◆	

**ISENSE ADC**

PARAMETER	MIN	TYP	MAX	UNITS		CONDITIONS
ADC Resolution		7		bit		
ADC LSB		5		mV		Referred to the input
Input Dynamic Range	0		-320	mV		

**PWM GENERATORS and OSCILLATOR**

PARAMETER	MIN	TYP	MAX	UNITS		CONDITIONS
Output frequency range	300		1500	kHz	◆	Steps defined in the table in the "PWM Switching Frequency Setting" Section below.
Channel-to-channel phase shift step		90		deg		With 4 phase setting.
Channel-to-channel phase shift step		120		deg		With 3 phase setting.
Minimum On Time		40		ns		1nF of gate capacitance.
Minimum Off Time		125		ns		1nF of gate capacitance
CLOCK IN Synchronization Range	-5		5	%	◆	



**Digital Input/Output Pins**

3.3V CMOS logic compatible. 5V tolerant, maximum rating of 6.0V

PARAMETER	MIN	TYP	MAX	UNITS		CONDITIONS
Input Pin Low Level			0.8	V	◆	
Input Pin High Level	2.0			V	◆	
Input Pin Leakage Current			10	μA	◆	
Input pin Capacitance		5		pF		
Output Pin Low Level			0.4	V	◆	I <sub>SINK</sub> = 1mA
Output Pin High Level	2.4			V	◆	I <sub>SOURCE</sub> = 1mA
Output Pin High Level (no load)		3.3	3.6	V	◆	I <sub>SOURCE</sub> = 0mA

**I<sup>2</sup>C SPECIFICATION**

PARAMETER	MIN	TYP	MAX	UNITS		CONDITIONS
I2C Speed			400	kHz		Based upon I2C Master Clock
Input Pin Low Level, V <sub>IL</sub>			0.3 V <sub>IO</sub>	V		V <sub>IO</sub> = 3.3V ±10%
Input Pin High Level, V <sub>IH</sub>	0.7 V <sub>IO</sub>			V		V <sub>IO</sub> = 3.3V ±10%
Hysteresis of Schmitt Trigger inputs, V <sub>hys</sub>	0.05 V <sub>IO</sub>			V		V <sub>IO</sub> = 3.3V±10%
Output Pin Low Level (open drain or collector), V <sub>OL</sub>			0.4	V		I <sub>SINK</sub> = 3mA
Input leakage current	-10		10	μA		Input is between 0.1 V <sub>IO</sub> and 0.9 V <sub>IO</sub>
Output fall time from V <sub>IHmin</sub> to V <sub>ILmax</sub>	20 + 0.1 C <sub>b</sub>		250	ns		With a bus capacitance from 10pF to 400pF
Capacitance for each I/O Pin			10	pF		

Note

1. C<sub>b</sub> is the capacitance of one bus in pF

**GATE DRIVERS**

PARAMETER	MIN	TYP	MAX	UNITS		CONDITIONS
GH, GL Rise and Fall Time		30		ns		At 10% to 90% of full scale pulse. 1nF C <sub>load</sub>
GH, GL Pull-up On-State Output Resistance		3		Ω		
GH, GL Pull-down On-State Output Resistance		3		Ω		
GH, GL Pull-down Off-State Output Resistance		50		kΩ		V <sub>IN</sub> = V <sub>CCD</sub> = 0V.

**XRP7704 INTERNAL BLOCK DIAGRAM**

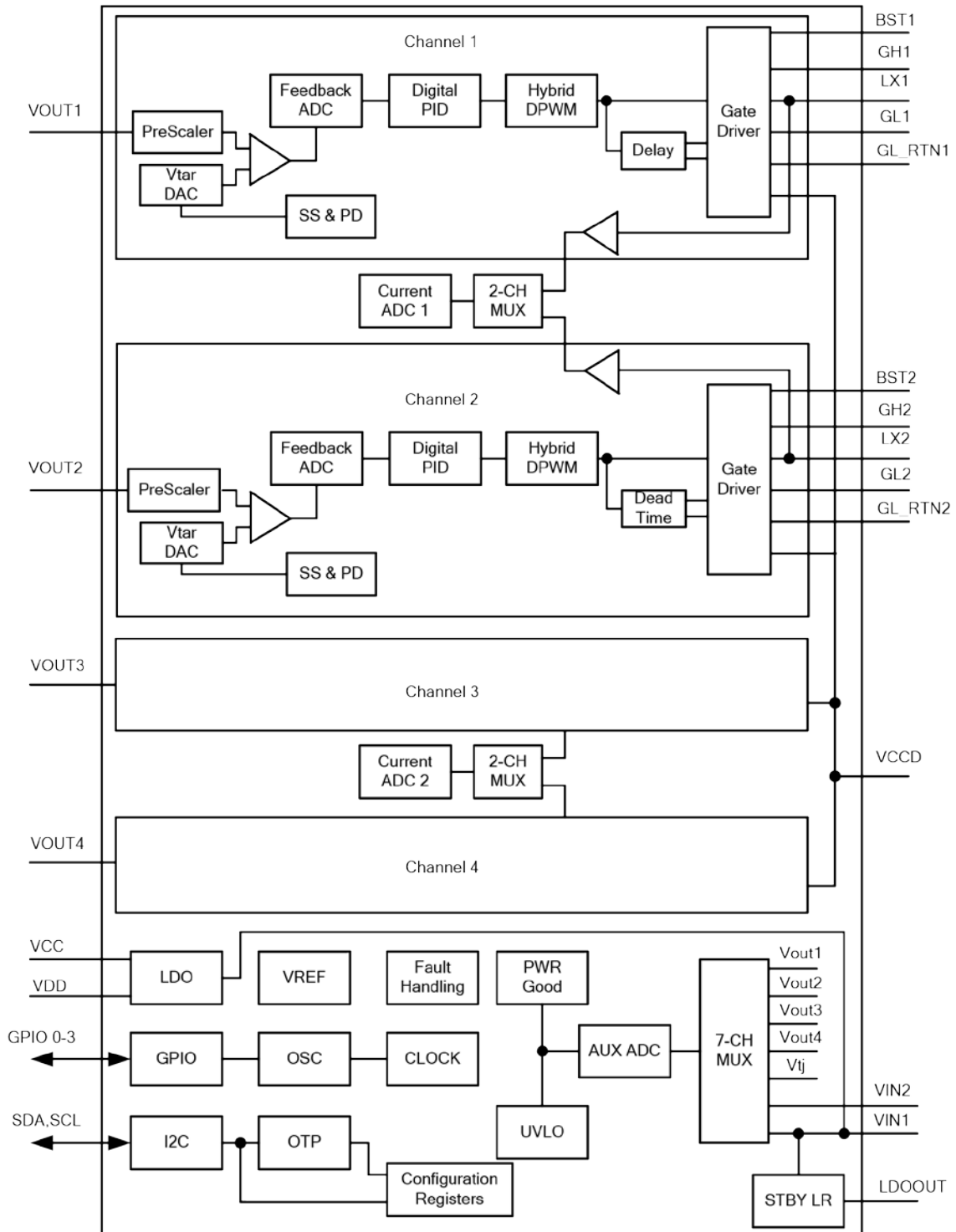

**XRP7704 PACKAGE OUTLINE – QFN**

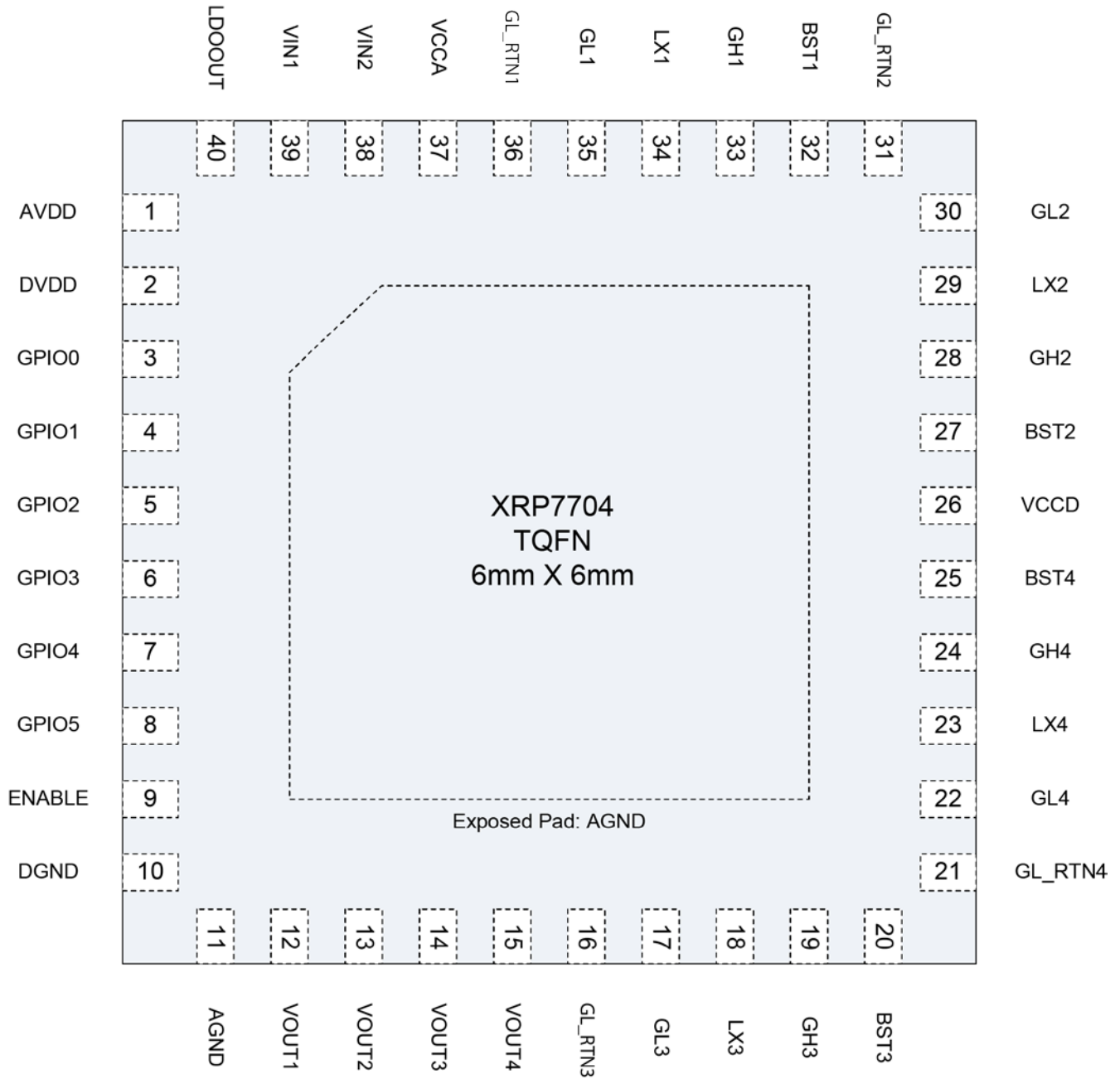

**PIN DESCRIPTION**

QFN PIN #	PIN NAME	DESCRIPTION
39	VIN1	Power source for the internal linear regulators to generate VCCA, VDD and the Standby LDO (LDOOUT). Place a decoupling capacitor close to the controller IC. Also used in UVLO1 fault generation – if VIN1 falls below the user programmed limit, all channels are shut down. The VIN1 pin needs to be tied to VIN2 on the board with a short trace.
38	VIN2	If the Vin2 pin voltage falls below the user programmed UVLO VIN2 level all channels are shut down. The VIN2 pin needs to be tied to VIN1 on the board with a short trace.
37	VCCA	Output of the internal 5V LDO. This voltage is internally used to power analog blocks. Note that a compensation capacitor should be used on this pin [see Application Note].
26	VCCD	Gate Drive input voltage. This is not an output voltage. This pin can be connected to VCCA to provide power for the Gate Drive. VCCD should be connected to VCCA with the shortest possible trace and decouple with a minimum 1uF capacitor. Alternatively, VCCD could be connected to an external supply (not greater than 5V).
36,31, 16,21	GL_RTN1- GL_RTN4	Power Ground. Ground connection for the low side gate driver.
1	AVDD	Output of the internal 1.8V LDO. A decoupling capacitor should be placed between AVDD and AGND close to the chip (with short traces).
2	DVDD	Input for powering the internal digital logic. This pin should be connected to AVDD.
10	DGND	Digital Ground. This pin should be connected to the ground plane at the exposed pad with a separate trace.
11	AGND	Analog Ground. This pin should be connected to the ground plane at the exposed pad with a separate trace.
17,22, 30,55	GL1-GL4	Output pin of the low side gate driver. Connect directly to the respective gate of an external N-channel MOSFET.
19,24, 28,33	GH1-GH4	Output pin of the high side gate driver. Connect directly to the respective gate of an external N-channel MOSFET.
34,29, 23,18	LX1-LX4	Lower supply rail for the high-side gate driver (GHx). Connect this pin to the switching node at the junction between the two external power MOSFETs and the inductor. These pins are also used to measure voltage drop across bottom MOSFETs in order to provide output current information to the control engine.

32,27, 20,25	BST1-BST4	High side driver supply pin(s). Connect BST to an external boost diode and a capacitor as shown in the front page diagram. The high side driver is connected between the BST pin and LX pin.
3,4,5,6	GPIO0-GPIO3	These pins can be configured as inputs or outputs to implement custom flags, power good signals and enable/disable controls. A GPIO pin can also be programmed as an input clock synchronizing IC to external clock. Refer to the "GPIO Pins" Section and the "External Clock Synchronization" Section for more information.
7,8	GPIO4_SDA, GPIO5_SCL	I <sup>2</sup> C serial interface communication pins. These pins can be re-programmed to perform GPIO functions in applications when I <sup>2</sup> C bus is not used.
12,13, 14,15	VOUT1- VOUT4	Voltage sense. Connect to the output of the corresponding power stage.
40	LDOOUT	Output of the Standby LDO. It can be configured as a 5V or 3.3V output. A compensation capacitor should be used on this pin [see Application Note].
9	ENABLE	If ENABLE is pulled high, the chip powers up (logic reset, registers configuration loaded, etc.). If pulled low for longer than 100us, the XRP7704 is placed into shutdown.
Exposed PAD	AGND	Analog Ground. Connect to analog ground (as noted above for pin 11).

## ORDERING INFORMATION<sup>(1)</sup>

Part Number	Junction Temperature Range	Lead-Free	Package	Packaging Method
XRP7704ILB-F	-40°C to +125°C	Yes <sup>(2)</sup>	40-pin 6 x 6 mm TQFN	Tray
XRP7704ILBTR-F				Tape and Reel

### NOTES:

1. Refer to [www.exar.com/XRP7704](http://www.exar.com/XRP7704) for most up-to-date Ordering Information.
2. Visit [www.exar.com](http://www.exar.com) for additional information on Environmental Rating.



**APPLICATION INFORMATION, Typical Performance Data**

at  $T_A = 25^\circ\text{C}$ , unless otherwise specified.

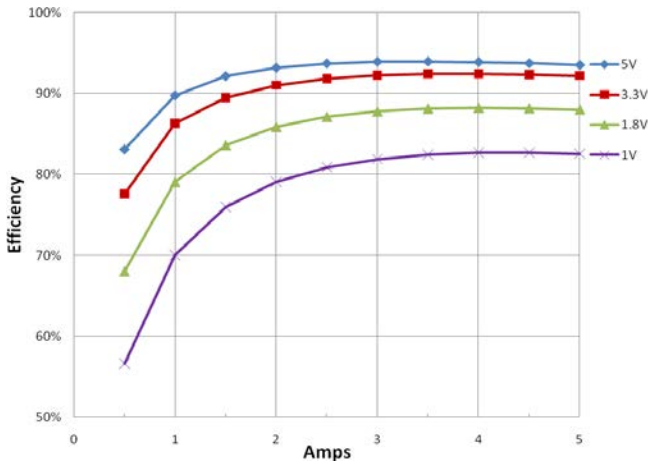

**12Vin Efficiency: Single Channel**  
 300kHz - Channels not in use are disabled  
 FET: Si4944; Inductor: 744314xxx 7x7x5mm

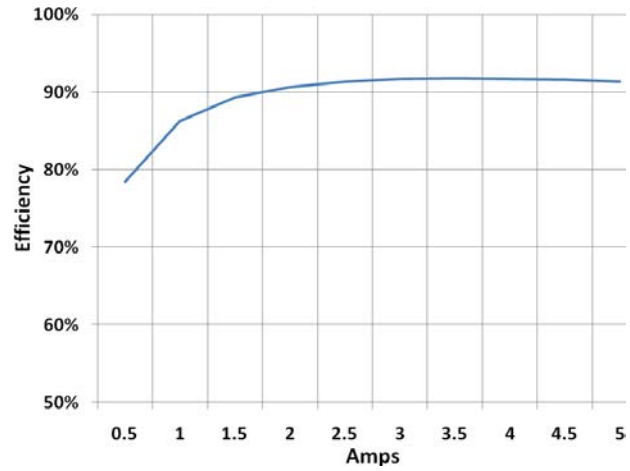

**12Vin Combined Efficiency: 5V, 3V3, 1V8 & 1V @ 5A**  
 300kHz PWM Frequency  
 FETs: Si4944; Inductor: 744314xxx 7x7x5mm

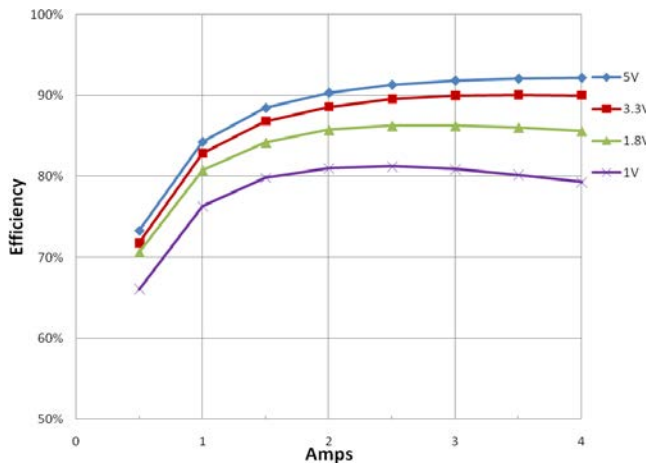

**12Vin Efficiency: Single Channel**  
 300kHz - Channels not in use are disabled  
 FET: FDS8984; Inductor: 744310200 7x7x3mm

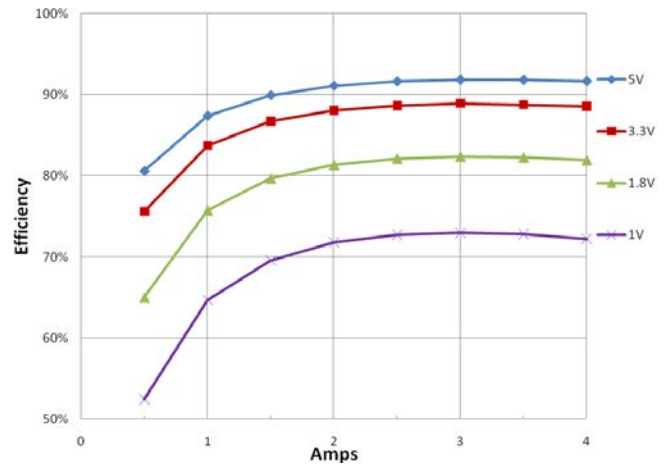

**12Vin Efficiency: Single Channel**  
 1MHz - Channels not in use are disabled  
 FET: FDS8984; Inductor: 744310200 7x7x3mm

**APPLICATION INFORMATION (Cont)**

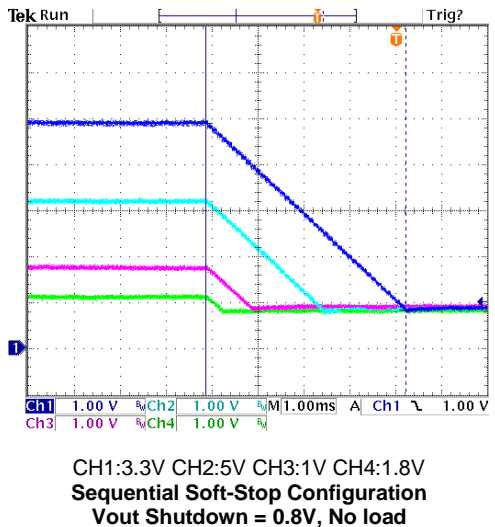
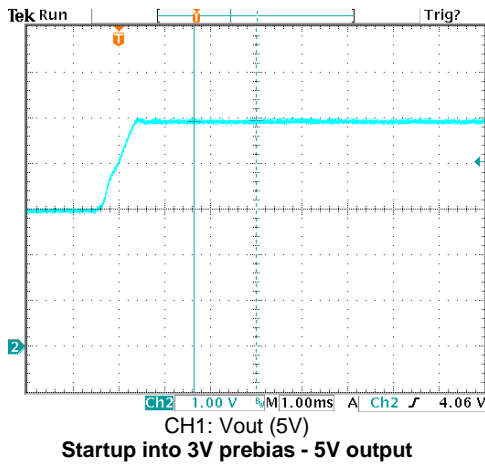
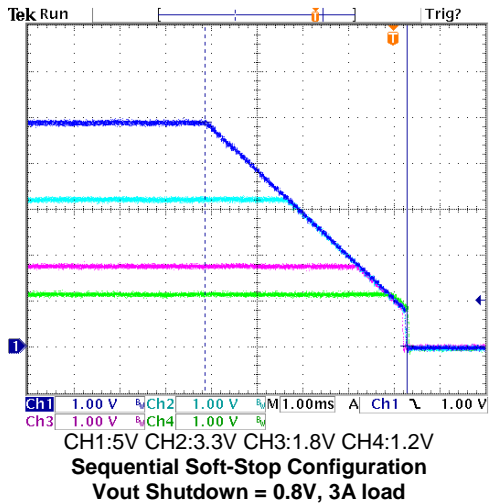
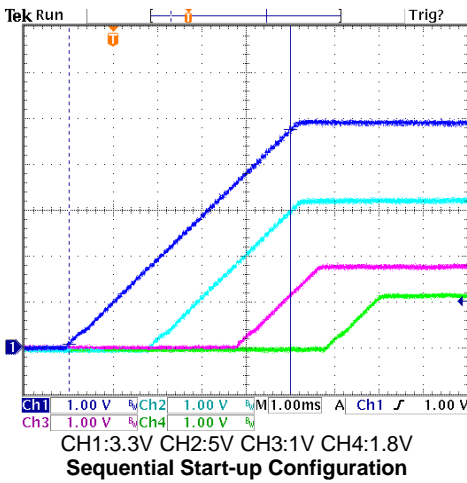
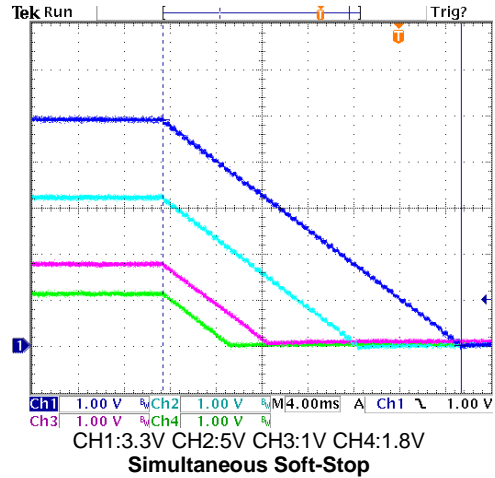
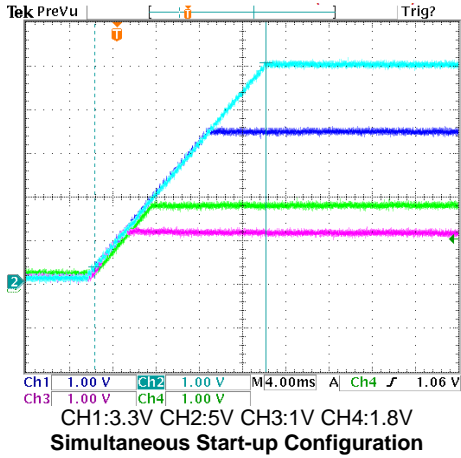

**APPLICATION INFORMATION (Cont)**

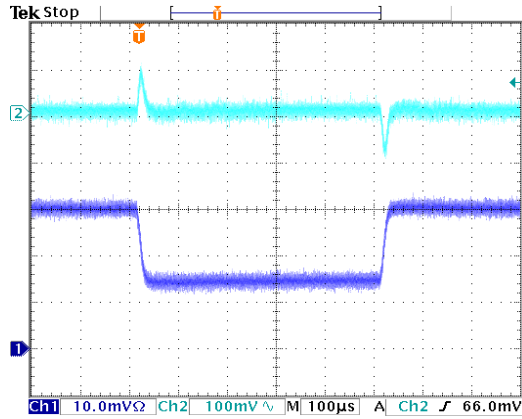

CH1:Iout (1A/div) CH2: Vout (3.3V)  
**Load Transient Response**

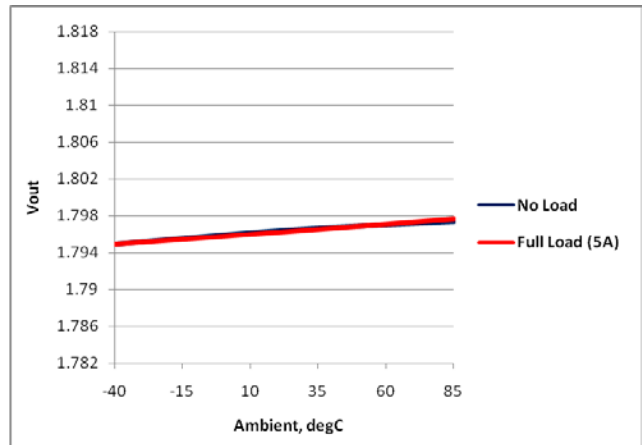

**Temperature Regulation**  
**1.8 V out (+/- 1% Vo window)**

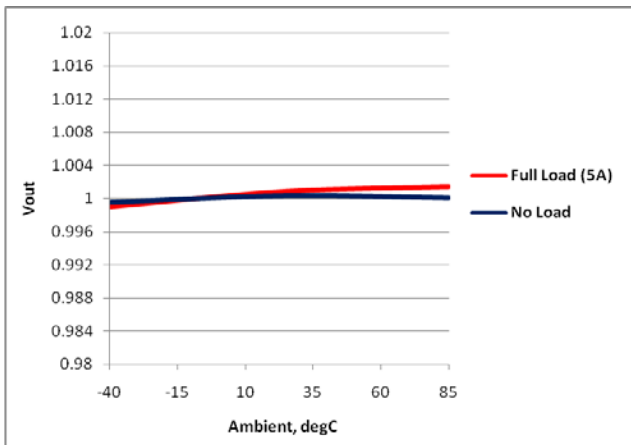

**Temperature Regulation**  
**1.0 V out (+/- 1% Vo window)**

## Features and Benefits

### General DPWM Benefits:

- Eliminate temperature and time variations associated with passive components in:
  - o Output set point
  - o Feedback compensation
  - o Frequency set point
  - o Under voltage lock out
  - o Input voltage measurement
  - o Gate drive dead time
- Tighter parameter tolerances including operating frequency set point
- Easy configuration and re-configuration for different VOUT, Iout, Cout, and Inductor selection by simply changing internal PID coefficients. No need to change external passives for a new output specification.
- Higher integration: Many external circuits can be handled by monitoring or modifying internal registers  
4 Independent DPWM channels in a small package
- Selectable DPWM frequency and Controller Clock Frequency

### Other Benefits:

- A single voltage is needed for regulation [no External LDO required].
- I<sup>2</sup>C interface allows:
  - o Communication with a System Controller or other Power Management devices for optimized system function
  - o Access to modify or read internal registers that control or monitor:
    - Output Current
    - Input and Output Voltage
    - Soft-Start/Soft-Stop Time
    - 'Power Good'
    - Part Temperature
    - Enable/Disable Outputs
    - Over Current
    - Over Voltage
    - Temperature Faults
    - Adjusting fault limits and disabling/enabling faults
- 6 Configurable GPIO pins, (4 if I<sup>2</sup>C is in use). Pins can be configured in several ways:
  - o Fault reporting (including OCP, OVP, Temperature, Soft-Start in progress, Power Good)
  - o Allows a Logic Level interface with other non-digital IC's or as logic inputs to other devices
  - o Possible to configure as traditional 'enable' pin for all 4 outputs
  - o 2 GPIOs can be dedicated to the I<sup>2</sup>C Interface as required by the customers design

- Frequency and Synchronization Capability
  - o Selectable switching frequency between 300kHz and 1.5MHz
  - o Each output can be programmed to any one of 4 possible phases
  - o Both internal clock and DPWM clock can be synchronized to external sources
  - o 'Master', 'Slave' and 'Stand-alone' Configurations are possible
- Internal MOSFET Drivers
  - o Internal FET drivers (3Ω) for each Channel
  - o Built-In Automatic Dead-time adjustment
  - o 30ns Rise and Fall times
  - o Soft-start into a pre-biased load and Soft-stop with programmable endpoint voltage
- GUI (Graphical User Interface) Design and Configuration Software:
  - o In its simplest form only VIN, VOUT, and Iout for each channel is required. The XRP7704 Configuration Software can generate all parts for a system bill of material including: Input Capacitor, FETs, Inductor and Output Capacitor.
  - o Tool calculates configuration register content based upon customer requirements. PID coefficients for correct loop response (for automatic or customized designs) can be generated and sent to the device.
  - o Configurations can be saved and/or recalled
  - o GPIOs can be configured easily and intuitively
  - o Synchronization configuration can be adjusted
  - o Interface can be used for real-time debugging and optimization
- Customizing XRP7704 with customer parameters
  - o Once a configuration is finalized it can be sent to MaxLinear and can reside in pre-programmed parts that customers can order with an individual part number.
  - o Allows parts to be used without I<sup>2</sup>C interface

### System Benefits:

- Reliability is enhanced via communication with the system controller which can obtain real time data on an output voltage, input voltage and current.
- System processors can communicate with the XRP7704 directly to obtain data or make adjustments to react to circuit conditions
- A system processor could also be configured to log and analyze operating history, perform diagnostics and if required, take the supply off-line after making other system adjustments.
- If customer field service is a possibility for your end product, parameter reporting and history would provide additional capabilities for troubleshooting or aid in future system upgrades.

## **XRP7704 FUNCTIONAL DESCRIPTION AND OPERATION**

The XRP7704 is a quad-output digital pulse width modulation (DPWM) controller with integrated gate drivers for the use in synchronous buck switching regulators. Each output voltage can be programmed from 0.9V to 5.1V without the need of an external voltage divider. The wide range of the programmable DPWM switching frequency (from 300 KHz to 1.5 MHz) enables the user to optimize for efficiency or component sizes. The digital regulation loop requires no external passive components for network compensation. The loop performance does not need to be compromised due to component tolerance, aging, and operating condition. Each digital controller provides a number of safety features, such as over-current protection (OCP) and over-voltage protection (OVP). The chip also provides over-temperature protection (OTP) and under-voltage lock-out (UVLO) for two input voltage rails. The XRP7704 also has up to 6 GPIOs and a Standby Linear Regulator to provide standby power. An I<sup>2</sup>C bus interface is provided to program the IC as well as to communicate with the host for fault reporting and handling, power rail monitoring, channel enable and disable, Standby Low Drop-out Regulator voltage reconfiguration, and Standby LDO enable and disable.

The XRP7704 offers a complete solution for soft-start and soft-stop. The delay and ramp of each PWM regulator can be independently controlled. When a pre-bias voltage is present, the device holds both high-side and low-side MOSFETs off until the reference voltage ramps up higher than the output voltage. As a result, large negative inductor current and output voltage disturbance are avoided. During soft-stop, the output voltage ramps down with a programmable slope until it reaches a pre-set stop voltage. This pre-set value can be programmed between within zero volts and the target voltage with the same set target voltage resolution (see shutdown waveforms in Applications).

### **Register Types**

There are two types of registers in the XRP7704: read/write registers and read-only registers. The read/write registers are used for the control functions of the IC and can be programmed using configuration non-volatile memory (NVM) or through an I<sup>2</sup>C command. The read-only registers are for feedback functions such as error/warning flags and for reading the output voltage or current.

### **Non-Volatile Configuration Memory**

The non-volatile memory (NVM) in XRP7704 stores the configuration data for the chip and all of the power rails. This memory is normally configured during manufacturing time. Once a specific bit of the NVM is programmed, that bit can never be reprogrammed again [i.e. one-time programmable]. During chip power up, the contents in the NVM are automatically transferred to the internal registers of the chip. Programmed cells have been verified to be permanent for at least 10 years and are highly reliable.

## Chip Power-Up

The figure below shows the power-up sequence of XRP7704 during the normal operation. The startup stage is divided into three phases. The first phase is the internal LDO power-up phase. The second phase is the configuration transfer phase. The third phase is chip ready phase. The power up sequence is less than 1ms.

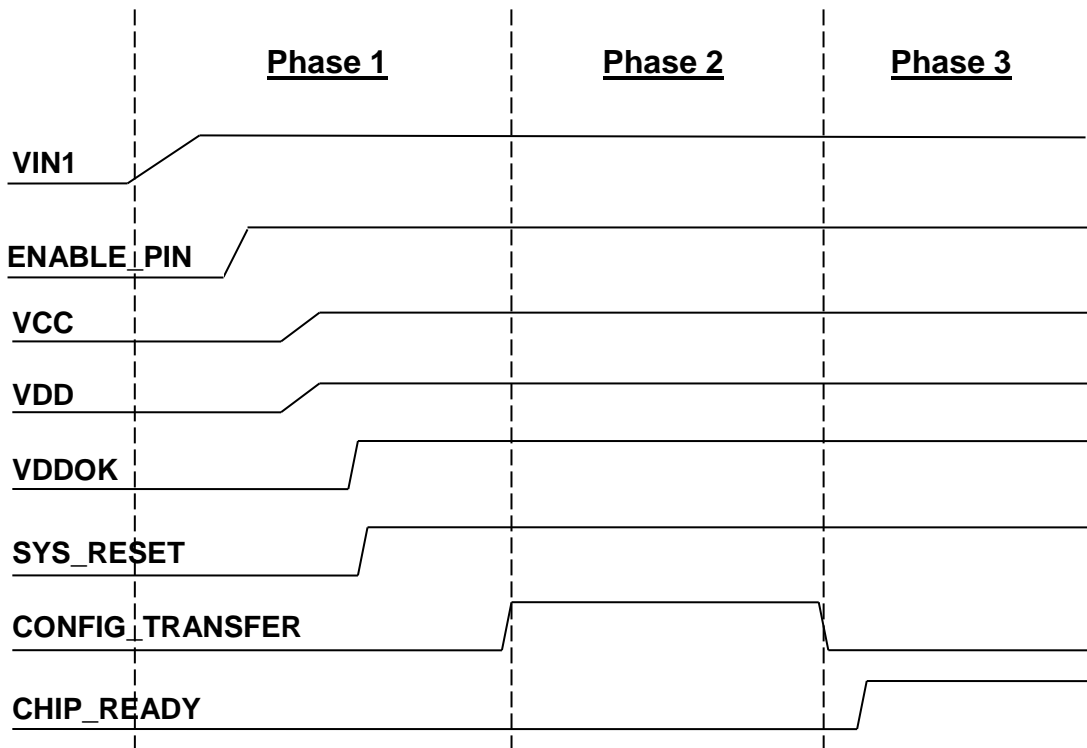

Power up sequence

### Internal LDO Power-Up Phase – Phase 1

When the ENABLE pin is set, internal VCC and VDD power up upon the power up of VIN1. Once the bandgap reference is stable and VCC and VDD fall into the acceptable range, an internal VDDOK flag is generated. A SYS\_RESET remains low for a few clock cycles to reset all the internal registers. After that the internal CONFIGURATION\_TRANSFER signal raises high and the chip transits to the second phase.

### Configuration Transfer Phase – Phase 2

In this phase, the contents in the configuration memory are transferred to the internal registers. The internal oscillator switches to the programmed switching frequency. The GPIO pins are properly configured as either inputs or outputs. If the chip is programmed to run in the I<sup>2</sup>C mode, GPIO4 and GPIO5 are configured to serve as SDA and SCL for the I<sup>2</sup>C bus. If chip is programmed to run in the NON-I<sup>2</sup>C mode, then these two pins can be used as GPIO4 and GPIO5 respectively.

### Chip Ready Phase – Phase 3

In this phase, the chip is ready for normal operation. An internal CHIP\_READY flag goes high and enables the I<sup>2</sup>C to acknowledge the Host's serial commands. Channels that are configured as always-on channels are enabled. Channels that are configured to be enabled by GPIOs are also enabled if the respective GPIO is asserted.

### Standby Low Drop-out Regulator

This 100mA low drop-out regulator can be programmed as 3.3V or 5V in **SET\_STBLDO\_EN\_CONFIG** register. Its output is seen on the LDOOUT Pin. This LDO is fully controllable via the Enable Pin (configured to turn on as soon as power is applied), a GPIO, and/or I<sup>2</sup>C communication.

### Enabling, Disabling and Reset

The XRP7704 is enabled via raising the ENABLE Pin high. The chip can then be disabled by lowering the same ENABLE Pin. There is also the capability for resetting the Chip via an I<sup>2</sup>C SOFTRESET Command.

For enabling a specific channel, there are several ways that this can be achieved. The chip can be configured to enable a channel at start-up as the default configuration residing in the non-volatile configuration memory of the IC. The channels can also be enabled using GPIO pins and/or an I<sup>2</sup>C Bus serial command. The registers that control the channel enable functions are the **SET\_EN\_CONFIG** and **SET\_CH\_EN\_I2C**.

### Internal Gate Drivers

The XRP7704 integrates Internal Gate Drivers for all 4 PWM channels. These drivers are optimized to drive both high-side and low side N-MOSFETs for synchronous operation. Both high side and low side drivers have the capability of driving 1 nF load with 30 ns rise and fall time. The drivers have built-in non-overlapping circuitry to prevent simultaneous conduction of the two MOSFETs.

### Fault Handling

While the chip is operating there are four different types of fault handling:

- **Under Voltage Lockout (UVLO)** monitors the input voltage to the chip, and the chip will shutdown all channels if the voltage drops to critical levels.
- **Over Temperature Protection (OTP)** monitors the temperature of the chip, and the chip will shutdown all channels if the temperature rises to critical levels.
- **Over Voltage Protection (OVP)** monitors the voltage of channel and will shutdown the channel if it surpasses its voltage threshold.
- **Over Current Protection (OCP)** monitors the current of a channel, and will shutdown the channel if it surpasses its current threshold. The channel will be automatically restarted after a 200ms delay.



### **Under Voltage Lockout (UVLO)**

There are two locations where the under voltage can be sensed: VIN1 and VIN2. The **SET\_UVLO\_WARN\_VINx** register that sets the under voltage warning set point condition at 100mV increments. When the warning threshold is reached, the Host is informed via a GPIO or by reading the **READ\_WARN\_FLAG** register.

The **SET\_UVLO\_TARG\_VINx** register that controls the under voltage fault set point condition at 100mV increments. This fault condition will be indicated in the **READ\_FAULT\_WARN** register.

When an under voltage fault condition occurs (either on VIN1 or VIN2), the fault flag register is set and all of the XRP7704 outputs are shut down. The measured input voltages can be read back using the **READ\_VIN1** or **READ\_VIN2** register, and both registers have a resolution of 100mV per LSB. When the UVLO condition clears (voltage rises above the UVLO Warning Threshold), the chip can be configured to automatically restart.

#### **VIN1**

This is a multi-function pin that provides power to both the Standby Linear Regulator and internal linear regulators to generate VCCA, VDD, and the Standby LDO (LDOUT).

It is also used as a UVLO detection pin. If Vin1 falls below its user programmed limit, all channels are shut down.

#### **VIN2**

VIN2 is required to be tied to VIN1 pin. It can be used as a UVLO detection pin. If VIN2 falls below its user programmed limit, all channels are shut down.

### **Temperature Monitoring and Over Temperature Protection (OTP)**

#### **Reading the junction temperature**

This register allows the user to read back the temperature of the IC. The temperature is expressed in Kelvin with a maximum range of 520K, a minimum of 200K, and an LSB of 5 degrees K. The temperature can be accessed by reading the **READ\_VTJ** register.

#### **Over Temperature Warning**

There are also warning and fault flags that get set in the **READ\_OVV\_UVLO\_OVT\_FLAG** register. The warning threshold is configurable to 5 or 10 Degrees C below the fault threshold. When the junction temperature reaches 5 or 10 Degrees C below the user defined set point, the over-temperature warning bit [*OTPW*] gets set in the **READ\_OVV\_UVLO\_OVT\_FLAG** register to warn the user that the IC might go into an over temperature condition (and shutdown all of the regulators).

#### **Over Temperature Fault**

If the over temperature condition occurs both the *OTP* and *OTPW* bits will be set in the **READ\_OVV\_UVLO\_OVT\_FLAG** register and the IC will shut down all channels (but I<sup>2</sup>C will remain operational). The actual over temperature threshold can be set by the user by using a 7bit **SET\_THERMAL\_SHDN** register with an LSB of 5K.

If the over temperature fault condition clears, then the IC can be set to restart the chip automatically. The restart temperature threshold can be set by the **SET\_THERMAL\_RESTART** register.



### Output Voltage Setting and Monitoring

The Output Voltage setting is controlled by the **SET\_VOUT\_TARGET\_CHx** register. This register allows the user to set the output voltage with a resolution of 50mV for output voltages between 0 and 2.5V and with a resolution of 100mV for output voltages between 2.6V and 5.1V. Output voltages higher than 5.1V can be achieved by adding an external voltage divider network. The output voltage of a particular channel can be read back using the **READ\_VOUTx** register.

#### Output Voltage from 0.9V to 5.1V

Per the equation below, for values between 0.9V and 5.1V the output voltage is equal to the binary number stored in the **SET\_VOUT\_TARGET\_CHx** register multiplied by 50mV. When programming an output voltage from 2.6V to 5.1V, odd binary values should be avoided. As a result, the set resolution for an output voltage higher than 2.5V is 100mV.

$$V_{OUT} = SET\_VOUT\_TARGET\_CHX \times 50mV$$

#### Output VOUT Higher Than 5.1V

To set the output voltage higher than 5.1V, the user needs to add an external voltage divider. The resistors used in the voltage divider should be below 10kΩ. The **SET\_VOUT\_TARGET\_CHx** register should be set to 0x32 which is equivalent to an output voltage of 2.5V without the external divider network. The output voltage regulation in this case might exceed 2% due to extra error from the resistor divider. *R1* and *R2* follow the definition below.

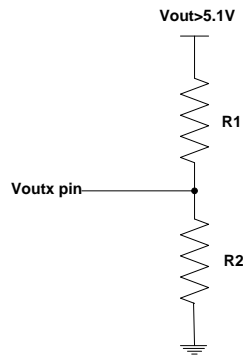

**External divider network for high output voltage**

$$V_{OUT} = \left( \frac{R1}{R2} + 1 \right) \times SET\_VOUT\_TARGET\_CHX \times 30mV$$

#### Output Voltage Lower Than 0.9V

The XRP7704 can be programmed to regulate an output voltage lower than 0.9V. However, in this case the specification of ±2% output voltage accuracy may be exceeded.

### **Over-Voltage Protection (OVP)**

The Over-Voltage Protection (OVP) **SET\_OVVP\_REGISTER** sets the over-voltage condition in predefined steps per channel. The over-voltage protection is always active even during soft-start condition. When the over-voltage condition is tripped, the controller will shut down the channel. When the channel is shut down the controller will then set corresponding OVP Fault bits in the **READ\_OVV\_UVLO\_OVT\_FLAG** register.

The VOUT OVP Threshold is 150mV to 300mV above nominal VOUT for a Voltage Target of 2.5V or less. For the Voltage Target of 2.6V to 5.1V, the VOUT OVP Threshold is 300mV to 600mV.

Once the over-voltage Channel is disabled, the controller will check the **SET\_FAULT\_RESP\_CONFIG\_LB** and **SET\_FAULT\_RESP\_CONFIG\_HB** to determine whether there are any “following” channels that need to be shut down. Any following channel will be disabled when the channel with the Over Voltage Fault is disabled. The channel(s) will remain disabled, until the Host takes action to enable the channel(s).

Any of the fault and warning conditions can also be configured to be represented using the general purpose input output pins (GPIO) to use as an interface with non I<sup>2</sup>C compatible devices. For further information on this topic see the “GPIO Pins” Section.

During OVP fault shutdown of the channel, the customer has the option to choose two types of shutdown for each channel. The first shutdown is ‘passive shutdown’ where the IC merely stops outputting pulses. The second shutdown is a ‘brute force’ shutdown where the GL remains on as the channel reaches its discharged voltage. Note that if the ‘brute force’ method is chosen, then GL will permanently remain high until the channel is re-enabled.

### **Output Current Setting and Monitoring**

XRP7704 utilizes a low side MOSFET R<sub>dson</sub> current sensing technique. The voltage drop on R<sub>dson</sub> is measured by dedicated current ADC. The ADC results are compared to a maximum current threshold and an over-current warning threshold to generate the fault and warning flags.

#### **Maximum Output Current**

The maximum output current is set by the **SET\_VIOUT\_MAX\_CHx** register and **SET\_ISENSE\_PARAM\_CHx** register. The **SET\_VIOUT\_MAX\_CHx** register is an 8 bit register. Bits [5:0] set the maximum current threshold and bits [7:6] set the over-current warning threshold. The LSB for the current limit register is 5 mV and the allowed voltage range is between 0 and 315mV. To calculate the maximum current limit, the user needs to provide the MOSFET R<sub>dson</sub>. The maximum current can be calculated as:

$$I_{OUTMAX} = \frac{V_{sense}}{R_{dson} \times Kt}$$

Where Kt is the temperature coefficient of the MOSFET R<sub>dson</sub>; V<sub>sense</sub> is the voltage across R<sub>dson</sub>; I<sub>OUTMAX</sub> is the maximum output current.

#### **Over-Current Warning**

The XRP7704 also offers an Over-Current warning flag. This warning flag resides in the **READ\_OVC\_FLAG** register. The warning flag bit will be set when the output current gets to within a specified value of the output current limit threshold enabling the host to reduce power consumption. The **SET\_VIOUT\_MAX\_CHx** register allows the warning flag threshold to be set 10mV, 20mV, 30mV or 40mV below VIOUT\_MAX. The warning flag will be automatically cleared when the current drops below the warning threshold.

**Over-Current Fault Handling**

When an over-current condition occurs, PWM drivers in the corresponding channels are disabled. After a 200ms timeout, the controller is re-powered and soft-start is initiated. When the over-current condition is reached the controller will check the **SET\_FAULT\_RESP\_CONFIG\_LB** and **SET\_FAULT\_RESP\_CONFIG\_HB** to determine whether there are any “following” channels that need to be similarly restarted. The controller will also set the fault flags in **READ\_OVC\_FAULT\_WARN** register.

Typically the over-current fault threshold would be set to 130-140% of the maximum desirable output current. This will help avoid any over-current conditions caused by transients that would shut down the output channel.

**Chip Operation and Configuration**

**Soft-Start**

The **SET\_SS\_RISE\_CHx** register is a 16 bit register which specifies the soft-start delay and the ramp characteristics for a specific channel. This register allows the customer to program the channel with a 250us step resolution and up to a maximum 16ms delay.

Bits [15:10] specify the delay after enabling a channel but before outputting pulses; where each bit represents 250us steps. Bits [9:0] specify the rise time of the channel; these 10 bits define the number of microseconds for each 50mV increment to reach the target voltage.

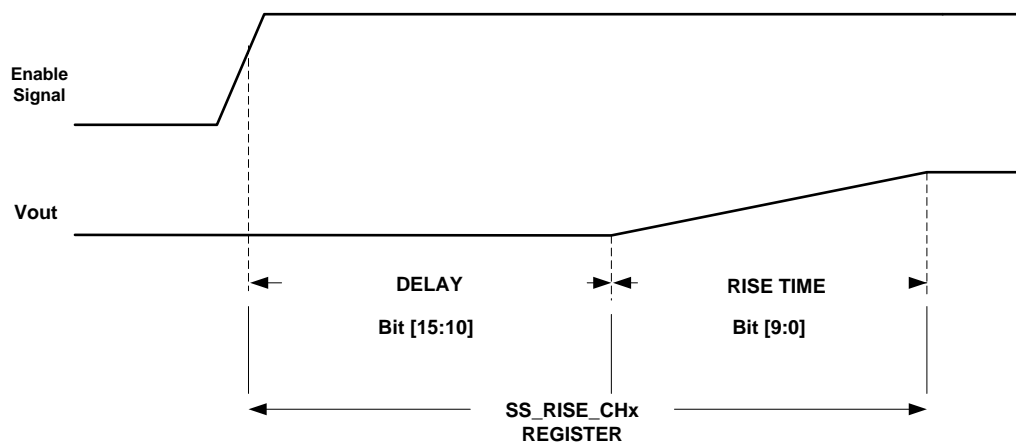

**Channel Power Up Sequence**

### Soft-Stop

The **SET\_PD\_FALL\_CHx** register is a 16 bit register. This register specifies the soft-stop delay and ramp (fall-time) characteristics for when the chip receives a channel disable indication from the Host to shutdown the channel.

Bits [15:10] specify the delay after disabling a channel but before starting the shutdown of the channel; where each bit represents 250us steps. Bits [9:0] specify the fall time of the channel; these 10 bits define the number of microseconds for each 50mV increment to reach the discharge threshold.

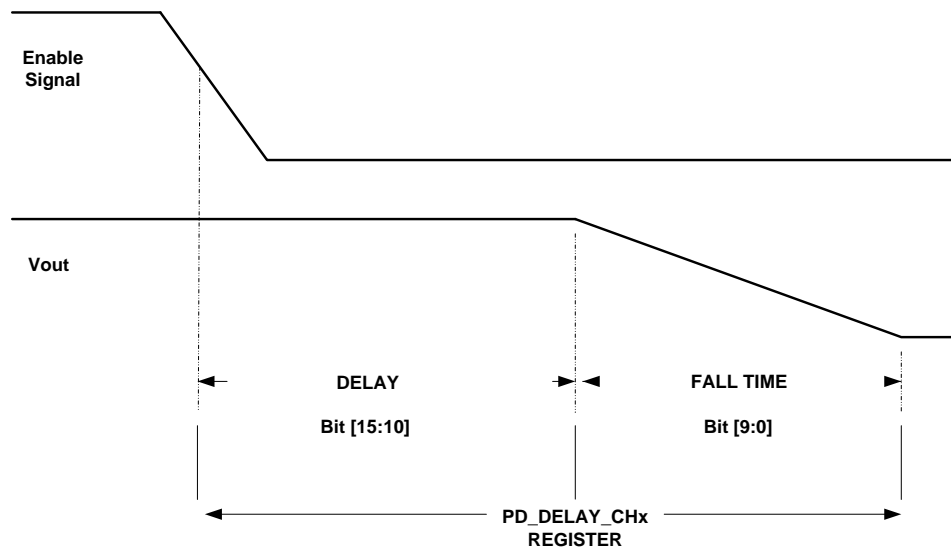

**Channel Soft-Stop Sequence**

### **Power Good Flag**

The XRP7704 allows the user to set the upper and lower bound for a power good signal per channel. The **SET\_PWRG\_TARG\_MAX\_CHx** register sets the upper bound, the **SET\_PWRG\_TARG\_MIN\_CHx** register sets the lower bound. Each register has a 20mV LSB resolution. When the output voltage is within bounds the power good signal is asserted high. Typically the upper bound should be lower than the over-voltage threshold. In addition, the power good signal can be delayed by a programmable amount set in the **SET\_PWRGD\_DLY\_CHx** register. The power good delay is only set after the soft-start period is finished. If the channel has a pre-charged condition that falls into the power good region, a power good flag is not set until the soft-start is finished.

### PWM Switching Frequency

The PWM switching frequency is set by choosing the corresponding oscillator frequency and clock divider ratio in the **SET\_SW\_FREQUENCY** register. Bits [6:4] set the oscillator frequency and bits [2:0] set the clock divider. The tables below summarize the available Main Oscillator and PWM switching frequency settings in the XRP7704.

#### **Main Oscillator Frequency**

SET_SW_FREQUENCY[6:4]	000	001	010	011	100	101	110	111
Main Oscillator Frequency	48MHz	44.8MHz	41.6MHz	38.4MHz	35.2MHz	32MHz	28.8MHz	25.6MHz
Ts	20.8ns	22.3ns	24ns	26ns	28.4ns	31.25ns	34.7ns	39ns

#### **PWM Switching Frequency**

SET_SW_FREQUENCY[2:0]	SET_SW_FREQUENCY[6:4]							
	000	001	010	011	100	101	110	111
000	NA	NA	NA	NA	NA	NA	NA	NA
001	1.5MHz	1.4MHz	1.3MHz	1.2MHz	1.1MHz	1.0MHz	900KHz	800KHz
010	1.0MHz	933KHz	867KHz	800KHz	733KHz	667KHz	600KHz	533KHz
011	750KHz	700KHz	650KHz	600KHz	550KHz	500KHz	450KHz	400KHz
100	600KHz	560KHz	520KHz	480KHz	440KHz	400KHz	360KHz	320KHz
101	500KHz	467KHz	433KHz	400KHz	367KHz	333KHz	300KHz	NA
110	429KHz	400KHz	370KHz	343KHz	314KHz	NA	NA	NA
111	375KHz	350KHz	325KHz	300KHz	NA	NA	NA	NA

#### **Setting the PWM switching frequency**

There are a number of options that could result in similar PWM switching frequency as shown above. In general, the chip consumes less power at lower oscillator frequency. When synchronization to external clock is needed, the user can choose the oscillator frequency to be within  $\pm 5\%$  of the external clock frequency. A higher Main Oscillator frequency will not improve accuracy or any performance efficiency.

#### **PWM Switching Frequency Considerations**

There are several considerations when choosing the PWM switching frequency.

##### **Minimum On Time**

Minimum on time determines the minimum duty cycle at the specific switching frequency. The minimum on time for the XRP7704 is 40ns.

$$\text{Minimum Duty Cycle\%} = \text{Minimum ontime} \times \text{PWM frequency} \times 100$$

As an example the minimum duty cycle is 4% for 1MHz PWM frequency. This is important since the minimum on time dictates the maximum conversion ratio that the PWM controller can achieve.

$$\text{Minimum Duty Cycle\%} > \frac{V_{out}}{V_{inmax}}$$

### Maximum Duty Cycle

The maximum duty cycle is dictated by the minimum required time to sample the current when the low side MOSFET is on. For the XRP7704, the minimum required sampling time is about 16 clock cycles at the main oscillator frequency. When calculating maximum duty cycle, the sampling time needs to be subtracted using the below equation. For example, if operating at 1MHz using the 32MHz main oscillator frequency, the maximum duty cycle would be:

$$\text{Maximum Duty Cycle\%} = (1 - ((16/\text{clock frequency}) \times \text{PWM frequency}) - 0.03) \times 100 = \sim 47\%$$

On the other hand, if the 48MHz main oscillator frequency was chosen for the 1MHz PWM frequency, the maximum duty cycle would be:

$$\text{Maximum Duty Cycle\%} = (1 - ((16/\text{clock frequency}) \times \text{PWM frequency}) - 0.03) \times 100 = \sim 64\%$$

Therefore, it is best to choose the highest main oscillator frequency for a particular PWM frequency if duty cycle limit might be encountered. The maximum duty cycle for any PWM frequency can easily be determined using the following table:

Main Osc. Frequency →	48MHz	44.8MHz	41.6MHz	38.4MHz	35.2MHz	32MHz	28.8MHz	25.6MHz
Maximum Duty Cycle ↓	PWM Frequency ↓							
47%	1.5MHz	1.4MHz	1.3MHz	1.2MHz	1.1MHz	1.0MHz	900KHz	800KHz
64%	1.0MHz	933KHz	867KHz	800KHz	733KHz	667KHz	600KHz	533KHz
72%	750KHz	700KHz	650KHz	600KHz	550KHz	500KHz	450KHz	400KHz
77%	600KHz	560KHz	520KHz	480KHz	440KHz	400KHz	360KHz	320KHz
80%	500KHz	467KHz	433KHz	400KHz	367KHz	333KHz	300KHz	NA
83%	429KHz	400KHz	370KHz	343KHz	314KHz	NA	NA	NA
85%	375KHz	350KHz	325KHz	300KHz	NA	NA	NA	NA

It is highly recommended that the maximum duty cycle obtained from the table above be programmed into each of the channels using the SET\_DUTY\_LIMITER\_CHx register. This ensures that under all conditions (including faults), there will always be sufficient sampling time to measure the output current. When the duty cycle limit is reached, the output voltage will no longer regulate and will be clamped based on the maximum duty cycle limit setting.

### Efficiency

The PWM Switching frequency plays an important role on overall power conversion efficiency. As the switching frequency increase, the switching losses also increase. Please see the **APPLICATION INFORMATION, Typical Performance Data** for further examples.

### Component Selection and Frequency

Typically the components become smaller as the frequency increases, as long as the ripple requirements remain constant. At higher frequency the inductor can be smaller in value and have a smaller footprint while still maintaining the same current rating.

## Frequency Synchronization Function and External Clock

The user of the XRP7704 can choose to use an external source as the primary clock for the XRP7704. This function can be configured using the **SET\_SYNC\_MODE\_CONFIG** register. This register sets the operation of the XRP7704 when an external clock is required. By selecting the appropriate bit combination the user can configure the IC to function as a master or a slave when two or more XRP7704s are used to convert power in a system. Automatic clock selection is also provided to allow operation even if the external clock fails by switching the IC back to an internal clock.

### External Clock Synchronization

Even when configured to use an external clock, the chip initially powers up with its internal clock. The user can set the percent target that the frequency detector will use when comparing the internal clock with the clock frequency input on the GPIO pin. If the external clock frequency is detected to be within the window specified by the user, then a switchover will occur to the external clock. If the IC does not find a clock in the specified frequency target range then the external clock will not be used and the IC will run on the internal clock that was specified by the user. If the external clock fails the user can choose to have the internal clock take over, using the automatic switch back mode in the **SET\_SYNC\_MODE\_CONFIG** register.

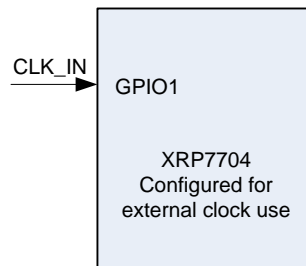

### XRP7704 Configured For External Clock Use

#### Synchronized Operation as a Master and Slave Unit

Two XRP7704s can be synchronized together. This Master-Slave configuration is described below.

##### Master

When the XRP7704 powers up as a master unit after the internal configuration memory is loaded the unit will send CLK\_OUT and SYNC\_OUT signals to the slave on the preconfigured GPIO pins.

##### Slave

When powering in sync mode the slave unit will initially power up with its internal clock to transfer the configuration memory. Once this transfer occurs, then the unit is set to function as a slave unit. In turn the unit will take the external clock provided by the master to run as its main internal clock.

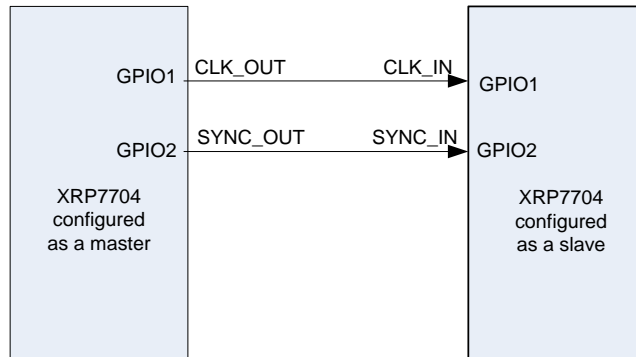

**Master/Slave configure of the XRP7704**

**External Clock Synchronization Master Slave combination**

When an external clock is used, the user will need to setup the master to also have an external clock in function. All of the same rules apply as in the External clock synchronization, Synchronized operation as a Slave unit section of this document. There are two ways of synchronizing this, either the external clock going to both Master/Slave CLK\_IN, or CLK\_IN can go to the Master, and the Master can synchronize SYNC\_OUT and CLK\_OUT to the Slave.

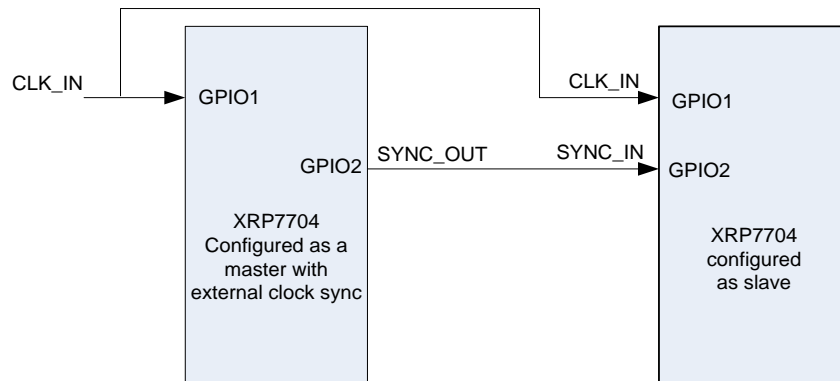

**External clock synchronization Master Slave combination**

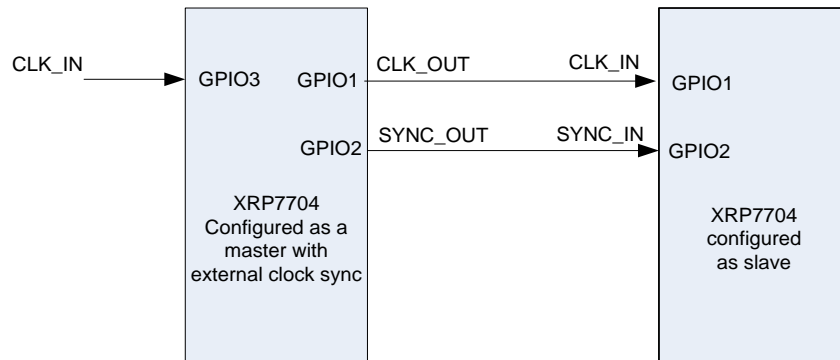

**Alternative External clock synchronization Master Slave combination**



## **Phase Shift**

Each switching channel can be programmed to a phase shift of the multiples of 90 degrees [for a 4 phase configuration] or 120 degrees [for a 3 phase configuration]. Two or more of the channels can use the same phase shift, however, it is preferable to run each channel at separate phases.

## **GPIO Pins**

The General Purpose Input Output (GPIO) Pins are the basic interface between the XRP7704 and the system. Although all of the stored data within the IC can be read back using the I<sup>2</sup>C bus it is sometimes convenient to have some of those internal registers to be displayed and or controlled by a single data pin. Besides simple input output functions the GPIO pins can be configured to serve as external clock inputs. These pins can be programmed using OTP bits or can be programmed using the I<sup>2</sup>C bus. This **GPIO\_CONFIG** register allows the user close to 100 different configuration functions that the GPIO can be programmed to do.

**NOTE: the GPIO Pins (and all I/Os) should NOT be driven without a 10K resistor when VIN is not being applied to the IC.**

## **GPIO Pins Polarity**

The polarity of the GPIO pin can be set by using the **GPIO\_ACT\_POL** register. This register allows any GPIO pin whether configured as an input or output to change polarity. Bits [5:0] are used to set the polarity of GPIO 0 through 5. If the IC operates in I<sup>2</sup>C mode, then the commands for Bits [5:4] are ignored.

## **Supply Rail Enable**

Each GPIO can be configured to enable a specific power rail for the system. The **GPIOx\_CFG** register allows a GPIO to enable/disable any of the following rails controlled by the chip:

- A single buck power controller
- The Standby LDO
- Any mix of the Standby LDO and power controller(s)

When the configured GPIO is asserted externally, the corresponding rails will be enabled, and they will be similarly disabled when the GPIO is de-asserted. This supply enabling/disabling can also be controlled through the I<sup>2</sup>C interface.

## **Power Good Indicator**

The GPIO pins can be configured as Power Good indicators for one or more rails. The GPIO pin is asserted when all rails configured for this specific IO are within specified limits for regulation. This information can also be found in the **READ\_PWRGD\_SS\_FLAG** status register.

## Fault and Warning Indication

The GPIOs can be configured to signal Fault or Warning conditions when they occur in the chip. Each GPIO can be configured to signal one of the following:

- OCP Fault on Channel 1 - 4
- OCP Warning on Channel 1 - 4
- OVP Fault on Channel 1 - 4
- UVLO Fault on VIN1 or VIN2
- UVLO Warning on VIN1 or VIN2
- Over Temperature Fault or Warning

## I<sup>2</sup>C Communication

The I<sup>2</sup>C communication is standard 2-wire communication available between the Host and the IC. This interface allows for the full control, monitoring, and reconfiguration of the semiconductor.

The I<sup>2</sup>C Slave address is saved in the NVM. Therefore, each customer can choose the 7-bit Slave Address which will work best in their design (in relation to any other I<sup>2</sup>C devices on the bus).

## External Component Selection

### Inductor Selection

Select the Inductor for inductance L and saturation current Isat. Select an inductor with Isat higher than the programmed over current limit. Calculate inductance from:

$$L = \frac{(V_{in} - V_{out}) \times V_{out}}{V_{in}} \times \frac{1}{f_s} \times \frac{1}{I_{rip}}$$

Where:

VIN is the converter input voltage

VOU is the converter output voltage

fs is the switching frequency

Irip is the inductor peak-to-peak current ripple (nominally set to 30% of Iout)

Keep in mind that a higher Irip results in a smaller inductance value which has the advantages of smaller size, lower DC equivalent resistance (DCR), and allows the use of a lower output capacitance to meet a given step load transient. A higher Irip, however, increases the output voltage ripple, requires higher saturation current limit, and increases critical conduction. Notice that this critical conduction current is half of Irip.

## Capacitor Selection

### Output Capacitor Selection

Select the output capacitor for voltage rating, capacitance and Equivalent Series Resistance (ESR). Nominally the voltage rating is selected to be at least twice as large as the output voltage. Select the capacitance to satisfy the specification for output voltage overshoot/undershoot caused by the current step load. A sudden decrease in the load current forces the energy surplus in the inductor to be absorbed by Cout. This causes an overshoot in output voltage that is corrected by power switch reduced duty cycle. Use the following equation to calculate Cout:

$$C_{out} = L \times \frac{(I_2 - I_1)^2}{V_{os}^2 - V_{out}^2}$$

Where:

L is the output inductance  
 I2 is the step load high current  
 I1 is the step load low current  
 Vos is output voltage including the overshoot  
 VOUT is the steady state output voltage

Or it can be expressed approximately as:

$$C_{out} = L \times \frac{(I_2 - I_1)^2}{2V_{out} \times \Delta V}$$

Here,  $\Delta V = V_{os} - V_{out}$  is the overshoot voltage deviation.

Select ESR such that output voltage ripple (Vrip) specification is met. There are two components in Vrip. First component arises from the charge transferred to and from Cout during each cycle. The second component of Vrip is due to the inductor ripple current flowing through the output capacitor's ESR. It can be calculated for Vrip:

$$V_{rip} = I_{rip} \times \sqrt{ESR^2 + \left(\frac{1}{8 \times C_{out} \times fs}\right)^2}$$

Where:

Irip is the inductor ripple current  
 fs is the switching frequency  
 Cout is the output capacitance

Note that a smaller inductor results in a higher Irip, therefore requiring a larger Cout and/or lower ESR in order to meet Vrip.

### Input Capacitor Selection

Select the input capacitor for Voltage, Capacitance, ripple current, ESR and ESL. Voltage rating is nominally selected to be at least twice the input voltage. The RMS value of input capacitor current, assuming a low inductor ripple current, can be approximated as:

$$I_{in} = I_{out} \times \sqrt{D(1 - D)}$$

Where:

$I_{in}$  is the RMS input current  
 $I_{out}$  is the DC output current  
 $D$  is the duty cycle

In general, the total input voltage ripple should be kept below 1.5% of  $V_{IN}$ . The input voltage ripple also has two major components: the voltage drop on the main capacitor  $\Delta V_{Cin}$  and the voltage drop due to ESR -  $\Delta V_{ESR}$ . The contribution to Input voltage ripple by each term can be calculated from:

$$\Delta V_{Cin} = \frac{I_{out} V_{out} (V_{in} - V_{out})}{f_s C_{in} V_{in}^2}$$

$$\Delta V_{ESR} = ESR \times (I_{out} + 0.5 I_{rip})$$

Total input voltage ripple is the sum of the above:

$$\Delta V_{Tot} = \Delta V_{Cin} + \Delta V_{ESR}$$

### **Power MOSFETs Selection**

Selecting MOSFETs with lower  $R_{dson}$  reduces conduction losses at the expense of increased switching losses. A simplified expression for conduction losses is given by:

$$P_{cond} = I_{out}^2 \times R_{dson} \times \frac{V_{out}}{V_{in}}$$

MOSFET's junction temperature can be estimated from:

$$T_J = 2P_{cond} R_{thJA} + T_{ambient}$$

This assumes that the switching loss is the same as the conduction loss.  $R_{thJA}$  is the total MOSFET thermal resistance from junction to ambient.

**Mechanical Dimensions**

40 PIN 6x6mm TQFN

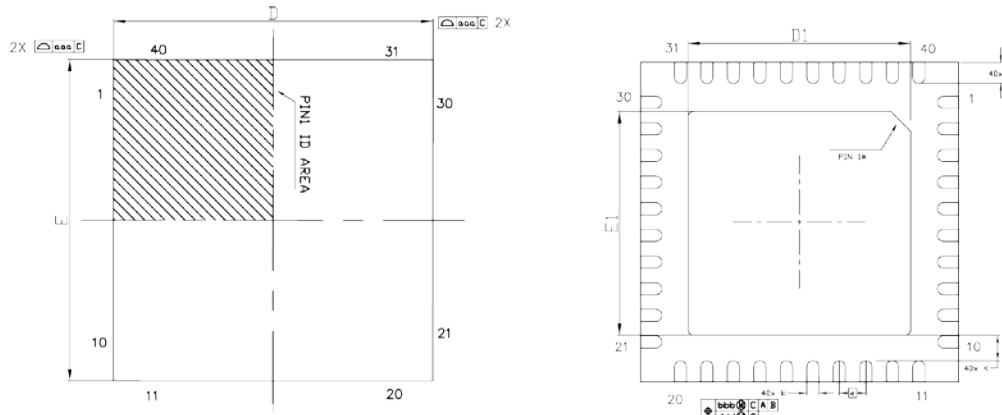

TOP VIEW

BOTTOM VIEW

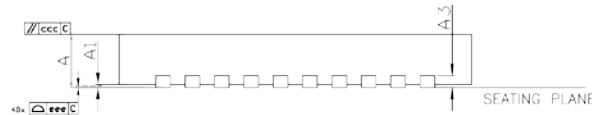

SIDE VIEW

DIMENSION TABLE			
SYMBOL	MIN	NOM	MAX
A	0.70	0.75	0.80
A1	0.00	0.02	0.05
A3	---	0.20Ref	---
b	0.20	0.25	0.30
D	6.00 BSC		
E	6.00 BSC		
e	0.50 BSC		
D1	4.40	4.50	4.60
E1	4.40	4.50	4.60
L	0.30	0.40	0.50
K	0.20	—	—
aaa		0.15	
bbb		0.10	
ccc		0.10	
ddd		0.05	
eee		0.08	
N		40	

TERMINAL DETAILS

- ALL DIMENSIONS ARE IN MILLIMETERS.
- DIMENSIONS AND TOLERANCE PER JEDEC MO-220.

**Recommended Land Pattern and Stencil**

40 PIN 6x6mm TQFN

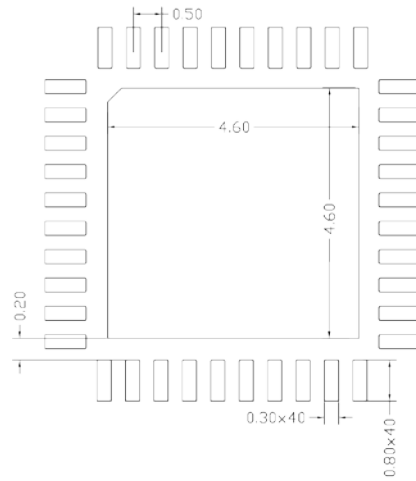

TYPICAL RECOMMENDED LAND PATTERN

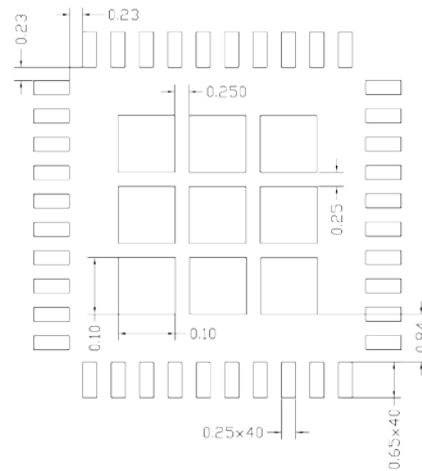

TYPICAL RECOMMENDED STENCIL

Drawing No.: POD- 00000137

Revision: A



## Revision History

DATE	REVISION	DESCRIPTION
September 2009	1.1.0	Initial release
June 2018	1.1.1	Updated to MaxLinear logo. Update format and Ordering Information. Changed PGND1-4 to GL_RTN1-4.



**Corporate Headquarters:**

5966 La Place Court  
Suite 100  
Carlsbad, CA 92008  
Tel.: +1 (760) 692-0711  
Fax: +1 (760) 444-8598  
[www.maxlinear.com](http://www.maxlinear.com)

**High Performance Analog:**

1060 Rincon Circle  
San Jose, CA 95131  
Tel.: +1 (669) 265-6100  
Fax: +1 (669) 265-6101  
[www.exar.com](http://www.exar.com)

The content of this document is furnished for informational use only, is subject to change without notice, and should not be construed as a commitment by MaxLinear, Inc.. MaxLinear, Inc. assumes no responsibility or liability for any errors or inaccuracies that may appear in the informational content contained in this guide. Complying with all applicable copyright laws is the responsibility of the user. Without limiting the rights under copyright, no part of this document may be reproduced into, stored in, or introduced into a retrieval system, or transmitted in any form or by any means (electronic, mechanical, photocopying, recording, or otherwise), or for any purpose, without the express written permission of MaxLinear, Inc.

MaxLinear, Inc. does not recommend the use of any of its products in life support applications where the failure or malfunction of the product can reasonably be expected to cause failure of the life support system or to significantly affect its safety or effectiveness. Products are not authorized for use in such applications unless MaxLinear, Inc. receives, in writing, assurances to its satisfaction that: (a) the risk of injury or damage has been minimized; (b) the user assumes all such risks; (c) potential liability of MaxLinear, Inc. is adequately protected under the circumstances.

MaxLinear, Inc. may have patents, patent applications, trademarks, copyrights, or other intellectual property rights covering subject matter in this document. Except as expressly provided in any written license agreement from MaxLinear, Inc., the furnishing of this document does not give you any license to these patents, trademarks, copyrights, or other intellectual property.

Company and product names may be registered trademarks or trademarks of the respective owners with which they are associated.

© 2009 – 2018 MaxLinear, Inc. All rights reserved