

CIRCUIT: SPDT

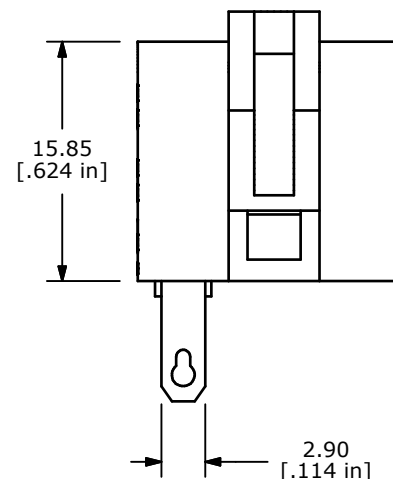

NOTE:

1. ALL DIMENSIONS IN MM [INCH]
2. GENERAL TOLERANCE: X.X=±0.4
X.XX=±0.25
3. TERMINAL NUMBERS FOR REF ONLY
4. RATING: 5A @ 250VAC; 8A @125VAC; 4A@ 250VAC
5. INSULATION RESISTANCE: 50 MEGA-OHMS (INITIAL)
6. ELECTRICAL LIFE: 30,000 MAKE-AND-BREAK CYCLES
7. CONTACT MATERIAL: SILVER
8. OPERATING TEMP.: -25°C to 55°C
9. STORAGE TEMP.: -40°C to 70°C
10. ▲ DENOTES CRITICAL PARAMETER.
11. 2002/95/EC (ROHS) COMPLIANT

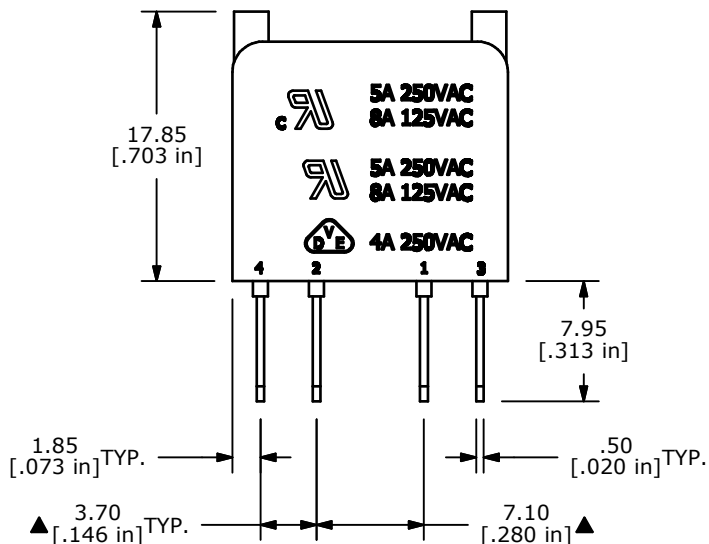

TITLE SPDT NON ILLUMINATED CONTACT BLOCK				
SCALE	DATE	DR	DWG	REV
2:1	8/30/2007	BF	F080000	A

A	17609	RELEASED FOR PRODUCTION	8/30/07	BF
REV	PCR NO	DESCRIPTION	DATE	BY
<small>THE INFORMATION CONTAINED IN THIS DOCUMENT IS PROPRIETARY TO E-SWITCH AND IS NOT TO BE COPIED OR TRANSFERRED</small>				