



## CODE 40 - TINEL-LOCK BACKSHELL

**TXR40AB00-1608AI-S**

SERIES \_\_\_\_\_  
 TXR: RING INCLUDED  
 (SEE RING OPTION)  
 TX: RING NOT INCLUDED  
 CONNECTOR INTERFACE \_\_\_\_\_  
 MATERIAL \_\_\_\_\_  
 REFER TO CH00-0250-008  
 FINISH \_\_\_\_\_  
 REFER TO CH00-0250-008  
 ANGLE \_\_\_\_\_  
 DASH NUMBER (TABLE 1) \_\_\_\_\_  
 ENTRY SIZE (TABLE 2) \_\_\_\_\_  
 RING OPTION \_\_\_\_\_  
 AI - TO SUIT SINGLE BRAID  
 BI - TO SUIT DOUBLE BRAID  
 FOR TX, LEAVE BLANK  
 MODIFICATION CODE \_\_\_\_\_  
 REFER TO CH00-0250-008 (2)

### NOTES:

1. THIS PRODUCT IS DESIGNED TO TERMINATE A BRAIDED CABLE SHIELD AND A HEAT SHRINKABLE LIPPED BOOT TO A CONNECTOR.
- (2) FOR ADDITIONAL DIMENSIONS, ORDERING INFORMATION AND MODIFICATIONS, SEE CH00-0250-008.
- (3) SEE DRAWING TR FOR DETAIL ON TINEL-LOCK RING, RINGS ARE DESIGNED TO BE HEATED ELECTRICALLY, ALL RINGS ARE MARKED WITH THERMOCHROMIC PAINT WHICH CHANGES COLOUR WHEN INSTALLATION TEMPERATURE IS REACHED.
4. BACKSHELL TO BE PERMANENTLY MARKED/BAGGED AND LABELLED WITH CODE IDENTIFICATION NUMBER AND PART NUMBER LESS RING DESIGNATOR. (e.g. 06090-TXR40AB00-1206). RING SHALL BEAR NO MARKING.
- (5) FOR LARGER ENTRY SIZES, A 2 PIECE BACKSHELL ASSEMBLY (TYPE 2) IS SUPPLIED.
6. BACKSHELL MATES TO MIL-DTL-38999, SERIES III AND IV, CLASS C, F, K, AND W, D38999/20, /24, /26, /40, /46 AND /47 CONNECTORS, AND WHEN SO MATED SHALL PROVIDE A WATER-TIGHT SEAL MEETING THE REQUIREMENTS OF MIL-C-85049, PARA. 3. 5. 7.
- (7) THESE DIMENSIONS APPLY IF A SELF-LOCKING COUPLING NUT IS USED.

DRAWN	K.WINCZURA	DATE	04/12/2014	 3RD ANGLE PROJECTION NOT TO SCALE  UNLESS OTHERWISE SPECIFIED ALL DIMENSIONS IN MILLIMETRES GENERAL TOL LINEAR +/-0.25MM ANGULAR +/- 1°	TITLE:	TINEL-LOCK BACKSHELL			 Polamco 
CHECKED		04/12/2014	ASSY USED ON:						
APPROVED	K.SHEPPARD	04/12/2014							
APPROVED	H.SMITH	15/06/2015							
REVISIONS									
LTR	DESCRIPTION	DATE	APPROVED						
K	REVISED PER ECO-15-002200	11.02.15	H.SMITH						
L	REVISED PER ECO-17-009011	21.06.17	D.JONES						
TE CAGE CODE: 06090 POLAMCO/TE CAGE CODE: U5792					TE CONNECTIVITY - POLAMCO LTD RESERVES THE RIGHT TO AMEND THIS DRAWING AND THE INFORMATION SET FORTH HEREON AT ANY TIME. USERS SHOULD INDEPENDENTLY EVALUATE THE SUITABILITY OF THE PRODUCT FOR THEIR APPLICATION.	DRAWING NO: <b>TXR40</b>	DRAWING REV: <b>L</b>	SHT <b>1</b>	



STRAIGHT BACKSHELL - TYPE 1



STRAIGHT BACKSHELL - TYPE 2

IF MAX ENTRY IS EXCEEDED BACKSHELL WILL BE SUPPLIED AS TYPE 2



45° BACKSHELL - TYPE 1

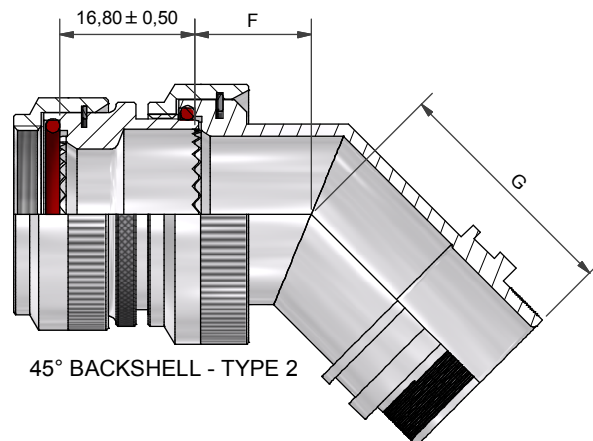

45° BACKSHELL - TYPE 2



90° BACKSHELL - TYPE 1

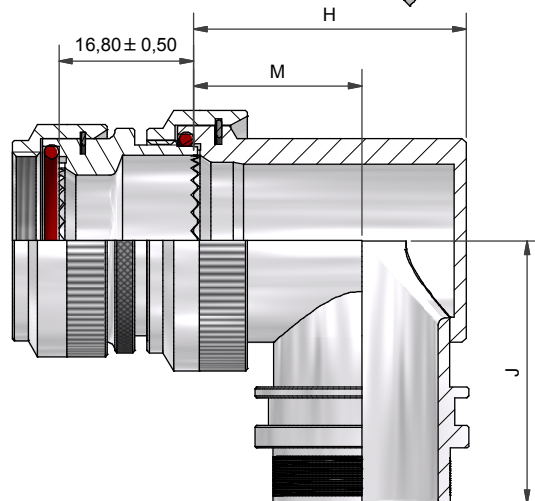

90° BACKSHELL - TYPE 2



90° BACKSHELL - TYPE 1  
STAINLESS STEEL AND  
NICKEL ALUMINIUM BRONZE



90° BACKSHELL - TYPE 2  
STAINLESS STEEL AND  
NICKEL ALUMINIUM BRONZE

DRAWN	K.WINCZURA	DATE	04/12/2014	 3RD ANGLE PROJECTION NOT TO SCALE
CHECKED		DATE	04/12/2014	
APPROVED	K.SHEPPARD	DATE	04/12/2014	
APPROVED	H.SMITH	DATE	15/06/2015	
UNLESS OTHERWISE SPECIFIED ALL DIMENSIONS IN MILLIMETRES <b>GENERAL TOL</b> LINEAR +/-0.25MM ANGULAR +/- 1°				

REVISIONS			
LTR	DESCRIPTION	DATE	APPROVED
K	REVISED PER ECO-15-002200	11.02.15	H.SMITH
L	REVISED PER ECO-17-009011	21.06.17	D.JONES

**TITLE:**  
TINEL-LOCK BACKSHELL

**ASSY USED ON:**  
MIL-DTL-38999 SERIES III & IV



TE CAGE CODE: 06090  
POLAMCO/TE CAGE CODE: U5792

TE CONNECTIVITY - POLAMCO LTD RESERVES THE RIGHT TO AMEND THIS DRAWING AND THE INFORMATION SET FORTH HEREON AT ANY TIME. USERS SHOULD INDEPENDENTLY EVALUATE THE SUITABILITY OF THE PRODUCT FOR THEIR APPLICATION.

DRAWING NO: <b>TXR40</b>	DRAWING REV: <b>L</b>	SHT <b>2</b>
-----------------------------	--------------------------	-----------------

# MODIFICATION S (SELF-LOCKING COUPLING NUT)



BACKSHELL - TYPE 1



BACKSHELL - TYPE 2

TABLE 1

ORDER NO.	SHELL SIZE COM'L / MIL	A THREAD	ØB MAX	ØB MAX $\langle 7 \rangle$	MAX ENTRY	C $\pm 0,5$	D $\pm 0,5$	W $\pm 0,5$	T $\pm 0,5$	E $\pm 0,5$	THESE DIMENSIONS APPLY IF BACKSHELL IS STAINLESS STEEL OR NICKEL ALUMINIUM BRONZE		
											W $\pm 0,5$	T $\pm 0,5$	E $\pm 0,5$
08	9 / A	M12 x 1.0	18,0	21,5	04	12,0	26,8	21,0	14,0	26,20	21,2	16,3	26,4
10	11 / B	M15 x 1.0	21,0	24,6	07	12,5	27,5	24,0	15,5	27,95	24,3	17,2	28,2
12	13 / C	M18 x 1.0	24,5	28,3	08	13,1	28,0	27,0	17,0	29,45	28,3	19,4	29,7
14	15 / D	M22 x 1.0	29,0	32,4	10	13,5	29,0	31,0	19,5	31,00	31,1	21,0	31,2
16	17 / E	M25 x 1.0	32,5	35,6	12	14,5	29,7	34,0	21,0	32,70	34,2	22,8	32,9
18	19 / F	M28 x 1.0	35,5	38,5	14	15,5	30,5	35,0	20,0	34,25	38,5	25,3	34,5
20	21 / G	M31 x 1.0	37,0	41,7	16	16,1	30,9	38,0	21,5	35,80	40,7	26,1	36,1
22	23 / H	M34 x 1.0	40,0	43,9	18	16,5	31,1	42,0	24,0	37,40	43,7	27,6	37,6
24	25 / J	M37 x 1.0	43,5	47,0	20	17,0	32,1	45,0	25,5	38,90	46,4	29,1	39,1

TABLE 2

ENTRY SIZE	ØZ MIN	ØS	ØY $\pm 0,3$	ØK MAX	ØK MAX $\langle 7 \rangle$	F $\pm 0,5$	G $\pm 0,5$	H $\pm 0,5$	M $\pm 0,5$	J $\pm 0,5$	THESE DIMENSIONS APPLY IF BACKSHELL IS STAINLESS STEEL OR NICKEL ALUMINIUM BRONZE		
											H $\pm 0,5$	M $\pm 0,5$	J $\pm 0,5$
04	6,35	9,49 +/-0,04	14,00	NA	NA	NA	NA	NA	NA	NA	NA	NA	NA
05	7,92	11,06 +/-0,04	15,50	21,0	24,6	12,5	27,5	24,0	15,5	27,95	24,3	17,2	28,2
06	9,53	12,66 +/-0,04	17,10	21,0	24,6	12,5	27,5	24,0	15,5	27,95	24,3	17,2	28,2
07	11,10	14,21 +/-0,07	18,70	21,0	24,6	12,5	27,5	24,0	15,5	27,95	24,3	17,2	28,2
08	12,70	15,81 +/-0,07	20,30	24,5	28,3	13,1	28,0	27,0	17,0	29,45	28,3	19,4	29,7
10	15,88	18,96 +/-0,08	23,50	29,0	32,4	13,5	29,0	31,0	19,5	31,00	31,1	21,0	31,2
12	19,05	22,14 +/-0,08	26,70	32,5	35,6	14,5	29,7	34,0	21,0	32,70	34,2	22,8	32,9
14	22,23	25,30 +/-0,08	29,80	35,5	38,5	15,5	30,5	35,0	20,0	34,25	38,5	25,3	34,5
16	25,40	28,48 +/-0,08	33,00	37,0	41,7	16,1	30,9	38,0	21,5	35,80	40,7	26,1	36,1
18	28,58	31,65 +/-0,08	36,20	40,0	43,9	16,5	31,1	42,0	24,0	37,40	43,7	27,6	37,6
20	31,75	34,83 +/-0,08	39,40	43,5	47,0	17,0	32,1	45,0	25,5	38,90	46,4	29,1	39,1
22	34,93	37,98 +/-0,08	42,50	48,5	50,0	18,5	35,3	54,5	31,0	42,00	50,0	31,0	42,0
24	38,10	41,15 +/-0,08	45,70	52,1	56,0	21,9	38,1	58,0	33,0	46,00	53,5	33,0	46,0

DRAWN	K.WINCZURA	DATE	04/12/2014	 3RD ANGLE PROJECTION NOT TO SCALE  UNLESS OTHERWISE SPECIFIED ALL DIMENSIONS IN MILLIMETRES GENERAL TOL LINEAR +/-0,25MM ANGULAR +/- 1°
CHECKED		DATE	04/12/2014	
APPROVED	K.SHEPPARD	DATE	04/12/2014	
APPROVED	H.SMITH	DATE	15/06/2015	

REVISIONS			
LTR	DESCRIPTION	DATE	APPROVED
K	REVISED PER ECO-15-002200	11.02.15	H.SMITH
L	REVISED PER ECO-17-009011	21.06.17	D.JONES

TITLE:		<b>TINEL-LOCK BACKSHELL</b>	
ASSY USED ON:		<b>MIL-DTL-38999 SERIES III &amp; IV</b>	



TE CAGE CODE: 06090  
POLAMCO/TE CAGE CODE: U5792

TE CONNECTIVITY - POLAMCO LTD RESERVES THE RIGHT TO AMEND THIS DRAWING AND THE INFORMATION SET FORTH HEREON AT ANY TIME. USERS SHOULD INDEPENDENTLY EVALUATE THE SUITABILITY OF THE PRODUCT FOR THEIR APPLICATION.

DRAWING NO:	DRAWING REV:	SHT
<b>TXR40</b>	<b>L</b>	<b>3</b>