

5	6	7	8
REV. B	ECN NO. LE3-910080	DATE 2009/01/16	SIGN Vicky
			DESCRIPTION Update the drawing.

THIS DOCUMENT IS SUBJECT TO CHANGE WITHOUT NOTICE. IT IS CONFIDENTIAL AND A PROPERTY OF Amphenol LTW. DISCLOSURE TO THIRD PARTY HAS TO BE AUTHORIZED BY Amphenol LTW.

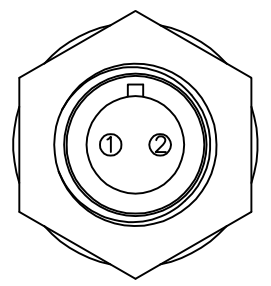

Pin Assignments
Front View

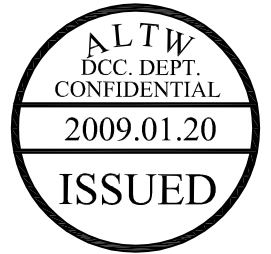
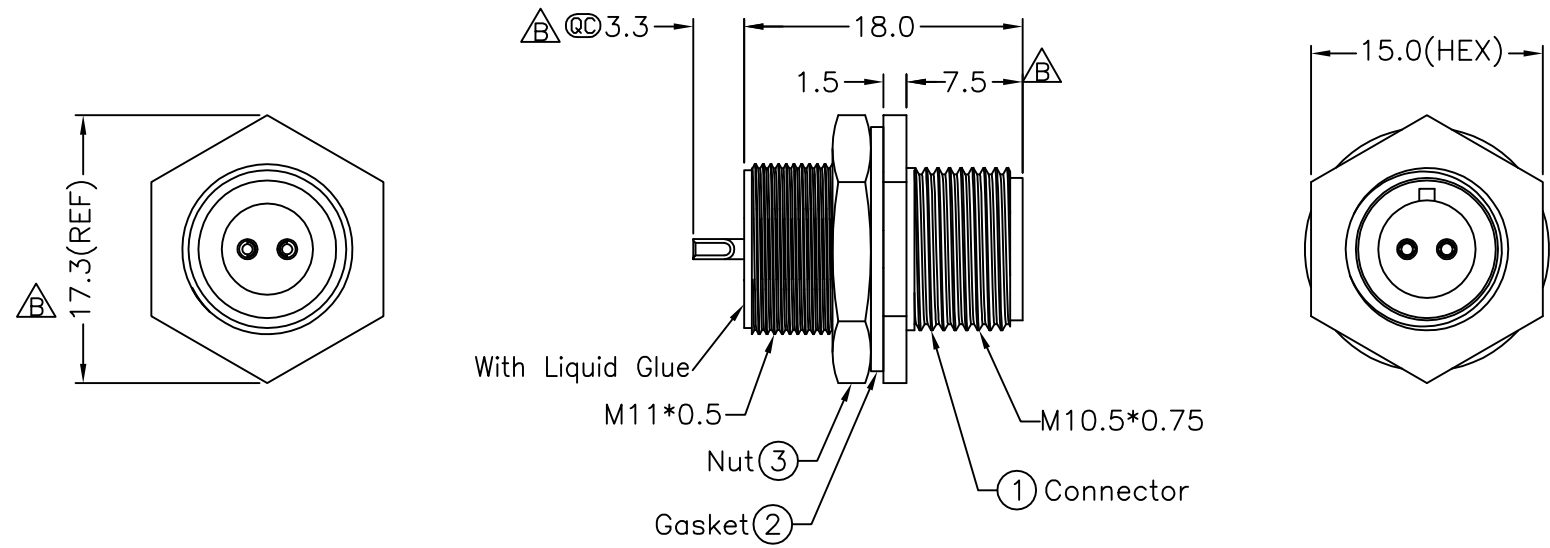
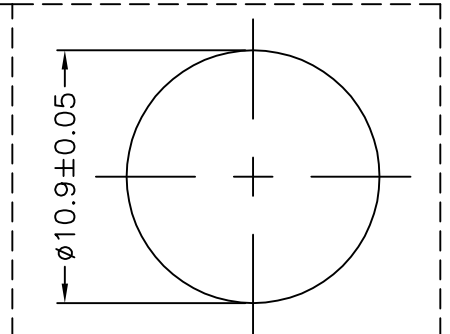

Recommended Panel Cut-Out

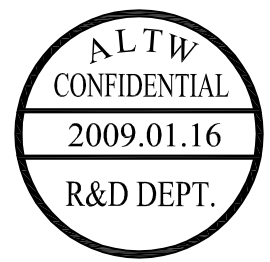

Notes:

- * @C Important Dimension.
- * Waterproof Rate:IP67.
- * Connector:Black,Nylon+GF.
- * Female Pin:Copper Alloy,Gold Plated.
- * Gasket:Black,EPDM.
- * Nut:Copper Alloy,Nickel Plated.
- * Shield:Copper Alloy,Nickel Plated.
- * For Panel Thickness Max:6.0mm.
- * @B Nut Torque:4~6 Kgf.cm

UNIT:mm		TITLE M10.5 Conn Panel Screw 2P M Conn F Pin	Amphenol LTW 安費諾亮泰企業股份有限公司		ITEM NO 105-02PMFS-SH7001	DRAWN BY Vicky	DATE 2009/01/16
TOLERANCE .X ±0.25 .XX ±0.1 .XXX ±0.05 ANGLES ±1'	SCALE Free	SHEET 1 OF 1		DWG NO 105-02PMFS-SH7001	CHECKED BY Ivan	DATE 2009/01/16	
REV. B	SIZE A4	@C :Inspection Item		CUSTOMER ALTW	APPROVED BY Luke	DATE 2009/01/16	