

SPEC

Spec No.	TQ3C-8EAF0-E1TAB02-00
Date	January 21, 2014

TYPE : T-55786GD084J-LW-AHN (TCG084SVLQ*PNN-AN*33)

< 8.4 inch SVGA transmissive color TFT

with LED backlight and constant current circuit for LED backlight>

CONTENTS

1. Application
2. Construction and outline
3. Mechanical specifications
4. Absolute maximum ratings
5. Electrical characteristics
6. Optical characteristics
7. Interface signals
8. Input timing characteristics
9. Lot number identification
10. Warranty
11. Precautions for use
12. Reliability test data
13. Outline drawing



KYOCERA DISPLAY CORPORATION

This specification is subject to change without notice.
Consult Kyocera display before ordering.

Original Issue Date	Designed by: Engineering dept.			Confirmed by: QA dept.	
	Prepared	Checked	Approved	Checked	Approved
January 21, 2014	<i>T. Andera</i>	<i>S. Ohtaka</i>	<i>M. Fujitani</i>	<i>O. Sato</i>	<i>I. Hamano</i>

Spec No. TQ3C-8EAF0-E1TAB02-00	Part No. T-55786GD084J-LW-AHN (TCG084SVLQ*PNN-AN*33)	Page -
-----------------------------------	--	-----------

Warning

1. This Kyocera LCD module has been specifically designed for use only in electronic devices and industrial machines in the area of audio control, office automation, industrial control, home appliances, etc. The module should not be used in applications where the highest level of safety and reliability are required and module failure or malfunction of such module results in physical harm or loss of life, as well as enormous damage or loss. Such fields of applications include, without limitation, medical, aerospace, communications infrastructure, atomic energy control. Kyocera expressly disclaims any and all liability resulting in any way to the use of the module in such applications.

2. Customer agrees to indemnify, defend and hold Kyocera harmless from and against any and all actions, claims, damages, liabilities, awards, costs, and expenses, including legal expenses, resulting from or arising out of Customer's use, or sale for use, or Kyocera modules in applications.

Caution

1. Kyocera shall have the right, which Customer hereby acknowledges, to immediately scrap or destroy tooling for Kyocera modules for which no Purchase Orders have been received from the Customer in a two-year period.

Spec No. TQ3C-8EAF0-E1TAB02-00	Part No. T-55786GD084J-LW-AHN (TCG084SVLQ*PNN-AN*33)	Page -
-----------------------------------	--	-----------

Revision record

Date		Designed by : Engineering dept.			Confirmed by : QA dept.	
		Prepared	Checked	Approved	Checked	Approved
Rev.No.	Date	Page	Descriptions			

1. Application

This document defines the specification of T-55786GD084J-LW-AHN. (TCG084SVLQ*PNN-AN*33)
(RoHS Compliant)

2. Construction and outline

LCD	: Transmissive color dot matrix type TFT
Backlight system	: LED
Polarizer	: Anti-Glare treatment
Interface	: LVDS
Additional circuit	: Timing controller, Power supply (3.3V input) With Constant current circuit for LED Backlight(12V input)

3. Mechanical specifications

Item	Specification	Unit
Outline dimensions 1)	199.5(W)×149(H)×(11.5)(D)	mm
Active area	170.4(W)×127.8(H) (21.3cm/8.4 inch(Diagonal))	mm
Dot format	800×(R,G,B)(W)×600(H)	dot
Dot pitch	0.071(W)×0.213(H)	mm
Base color 2)	Normally Black	-
Mass	TBD	g

1) Projection not included. Please refer to outline for details.

2) Due to the characteristics of the LCD material, the color varies with environmental temperature.

4. Absolute maximum ratings

4-1. Electrical absolute maximum ratings

Item	Symbol	Min.	Max.	Unit	
Supply voltage(+3.3V)	V _{DD}	-0.3	4.0	V	
Supply voltage(+12V)	V _{IN}	-0.3	14.0	V	
Input signal voltagee 2)	RxIN _i +, RxIN _i - 1)	V _{I1}	-0.3	2.8	V
	CK IN+, CK IN-	V _{I2}	-0.3	2.8	V
	SELLVDS	V _{I3}	-0.3	V _{DD} +0.5	V
	BLBRT, BLEN	V _{I4}	-0.3	V _{IN}	V

1) i=0,1,2,3

2) V_{DD} must be supplied correctly within the range described in 5-1.

4-2. Environmental absolute maximum ratings

Item	Symbol	Min.	Max.	Unit
Operating temperature(Ambient) 1)	T _{OP} (Ambient)	-30	80	°C
Operating temperature(Panel) 2)	T _{OP} (Panel)	-30	80	
Storage temperature 3)	T _{STO}	-30	80	°C
Operating humidity 4)	H _{OP}	10	5)	%RH
Storage humidity 4)	H _{STO}	10	5)	%RH
Vibration	-	6)	6)	-
Shock	-	7)	7)	-

1) Operating temperature means a temperature which operation shall be guaranteed. Since display performance is evaluated at 25°C, another temperature range should be confirmed.

2) Panel surface temperature (all the surface)

3) Temp. = -30°C < 48h , Temp. = 80°C < 168h

Store LCD at normal temperature/humidity. Keep them free from vibration and shock.

An LCD that is kept at a low or a high temperature for a long time can be defective due to other conditions, even if the low or high temperature satisfies the standard.

(Please refer to “Precautions for Use” for details.)

3) Non-condensing

4) Temp. ≤ 40°C, 85%RH Max.

Temp. > 40°C, Absolute humidity shall be less than 85%RH at 40°C.

5)

Frequency	10~55 Hz	Acceleration value (0.3~9 m/s ²)
Vibration width	0.15mm	
Interval	10-55-10 Hz	1 minutes

2 hours in each direction X, Y, Z (6 hours total)

EIAJ ED-2531

6) Acceleration: 490 m/s², Pulse width: 11 ms

3 times in each direction: ±X, ±Y, ±Z

EIAJ ED-2531

5. Electrical characteristics

5-1. LCD

Temp. = -30~80°C

Item	Symbol	Condition	Min.	Typ.	Max.	Unit
Supply voltage 1)	V_{DD}	-	3.0	3.3	3.6	V
Current consumption	I_{DD}	2)	-	270	350	mA
Permissible input ripple voltage	V_{RP}	$V_{DD}=3.3V$	-	-	100	mVp-p
Input signal voltage 3)	V_{IL}	"Low" level	0	-	0.8	V
	V_{IH}	"High" level	2.0	-	V_{DD}	V
Input leak current	I_{OL}	$V_{I3}=0V$	-10	-	10	μA
	I_{OH}	$V_{I3}=3.3V$	-	-	400	μA
LVDS Input voltage 4)	V_L	-	0	-	1.9	V
Differential input voltage 4)	V_{ID}	-	250	350	450	mV
Differential input threshold voltage 4) 5)	V_{TL}	"Low" level	$V_{CM}-100$	-	-	mV
	V_{TH}	"High" level	-	-	$V_{CM}+100$	mV
Terminator	R_1	-	-	100	-	Ω
V_{DD} -turn-on conditions 1)	t_1	-	0.1	-	10	ms
	t_2	-	0	-	-	ms
	t_3	-	0	-	-	ms
	t_4	-	1.0	-	-	s
	t_5	-	200	-	-	ms
	t_6	-	200	-	-	ms

1) V_{DD} -turn-on conditions

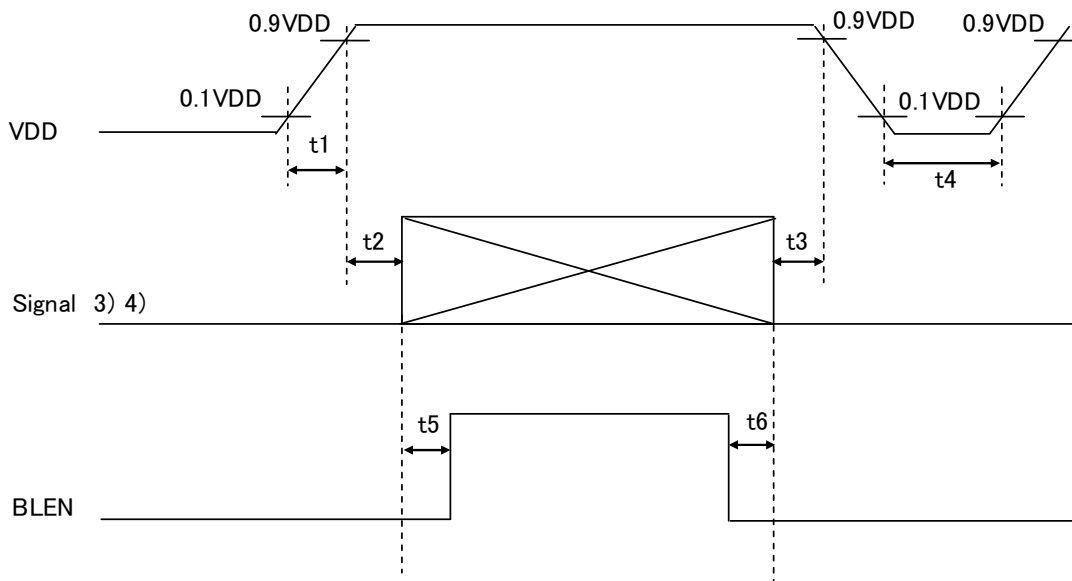

2) Display pattern:

$V_{DD} = 3.3V$, Temp. = 25°C

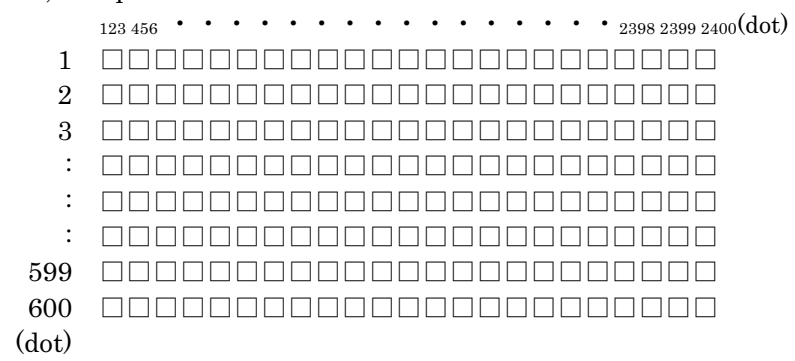

3) Input signal : SELLVDS

4) Input signal : RxIN3+, RxIN3-, RxIN2+, RxIN2-, RxIN1+, RxIN1-, RxIN0+, RxIN0-, CK IN+, CK IN-

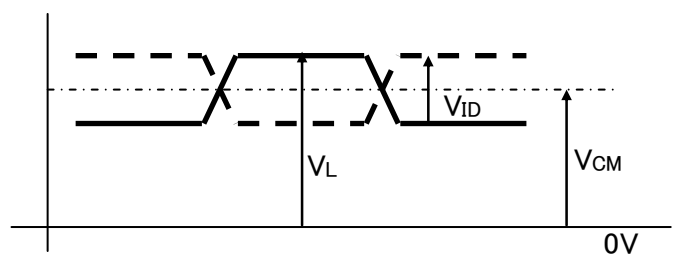

5) V_{CM} : LVDS Common mode voltage ($V_{CM}=1.25V$)

5-2. Constant current circuit for LED Backlight

Temp. = -30~80°C

Item	Symbol	Condition	Min.	Typ.	Max.	Unit
Supply voltage 1)	V_{IN}	-	10.8	12.0	13.2	V
Current consumption	I_{IN}	2)	-	(770)	(1000)	mA
Permissive input ripple voltage	V_{RP_BL}	$V_{IN}=12.0V$	-	-	100	mVp-p
BLBRT Input signal voltage	V_{IL_BLBRT}	"Low" level	0	-	0.8	V
	V_{IH_BLBRT}	"High" level	2.3	-	V_{IN}	V
BLBRT Input pull-down resistance	R_{IN_BLBRT}	-	100	300	500	k Ω
BLEN Input signal voltage	V_{IL_BLEN}	"Low" level	0	-	0.8	V
	V_{IH_BLEN}	"High" level	2.3	-	V_{IN}	V
BLEN Input pull-down resistance	R_{IN_BLEN}	-	100	300	500	k Ω
PWM Frequency 3)	f_{PWM}	-	200	-	10k	Hz
PWM Duty ratio	D_{PWM}	$f_{PWM}=200Hz$	1	-	100	%
		$f_{PWM}=2kHz$	10	-	100	%
		$f_{PWM}=10kHz$	50	-	100	%
Operating life time 4), 5)	T	Temp.=25°C	-	(70,000)	-	h

【LED Circuit】

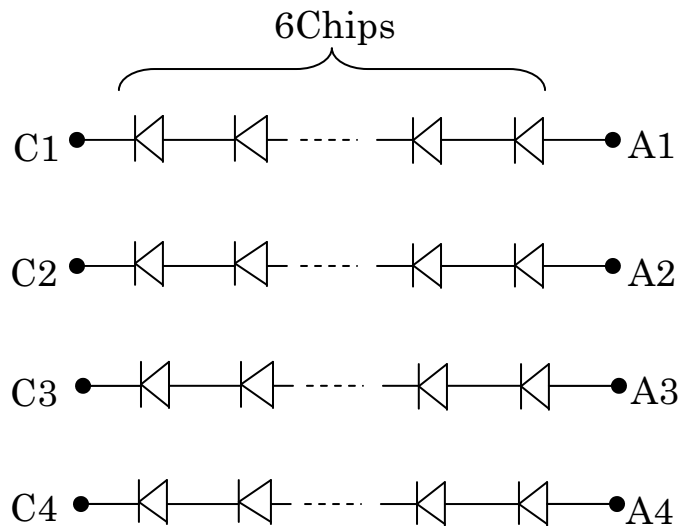

1) V_{IN} -turn-on conditions

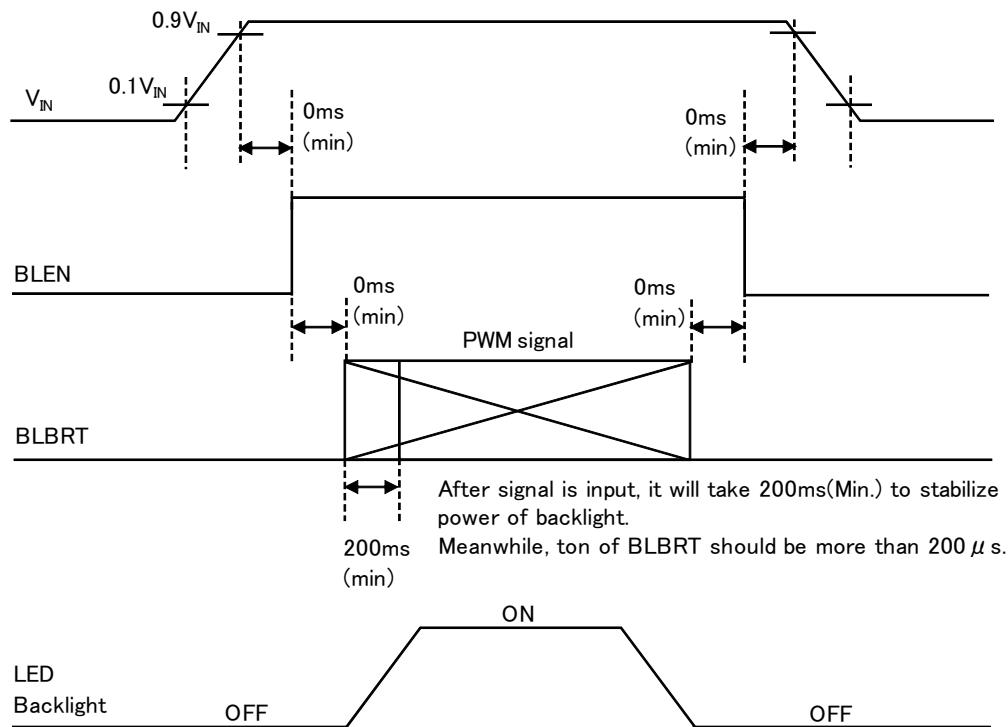

2) $V_{IN} = 12V$, Temp. = 25°C, $D_{PWM} = 100\%$

3) PWM Timing Diagram

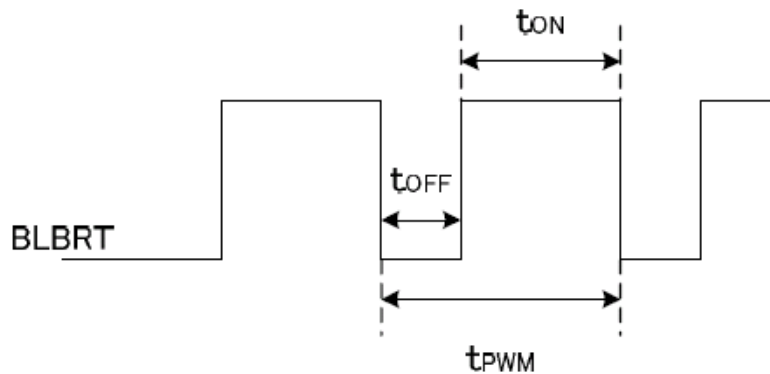

$$t_{ON}, t_{OFF} \geq 50 \mu s.$$

In case of lower frequency, the deterioration of the display quality, flicker etc., may occur.

- 4) When brightness decrease 50% of minimum brightness.
The average life of a LED will decrease when the LCD is operating at higher temperatures.
- 5) Life time is estimated data. (Condition : $I_F=100mA$, $T_a=25^\circ C$ in chamber).

6. Optical characteristics

Measuring spot = ϕ 6.0mm, Temp. = 25°C

Item	Symbol	Condition	Min.	Typ.	Max.	Unit	
Response time	Rise	τ_r	$\theta = \phi = 0^\circ$	-	18	-	ms
	Down	τ_d	$\theta = \phi = 0^\circ$	-	12	-	ms
Viewing angle range	θ UPPER	CR \geq 10	-	85	-	deg.	
	θ LOWER		-	85	-		
	ϕ LEFT		-	85	-	deg.	
	ϕ RIGHT		-	85	-		
Contrast ratio	CR	$\theta = \phi = 0^\circ$	(500)	(750)	-	-	
Brightness	L	IF=100mA/Line	-	(1200)	-	cd/m ²	
Chromaticity coordinates	Red	x	$\theta = \phi = 0^\circ$	TBD	TBD	TBD	
		y		TBD	TBD	TBD	
	Green	x	$\theta = \phi = 0^\circ$	TBD	TBD	TBD	
		y		TBD	TBD	TBD	
	Blue	x	$\theta = \phi = 0^\circ$	TBD	TBD	TBD	
		y		TBD	TBD	TBD	
	White	x	$\theta = \phi = 0^\circ$	TBD	TBD	TBD	
		y		TBD	TBD	TBD	

6-1. Definition of contrast ratio

$$\text{CR(Contrast ratio)} = \frac{\text{Brightness with all pixels "White"}}{\text{Brightness with all pixels "Black"}}$$

6-2. Definition of response time

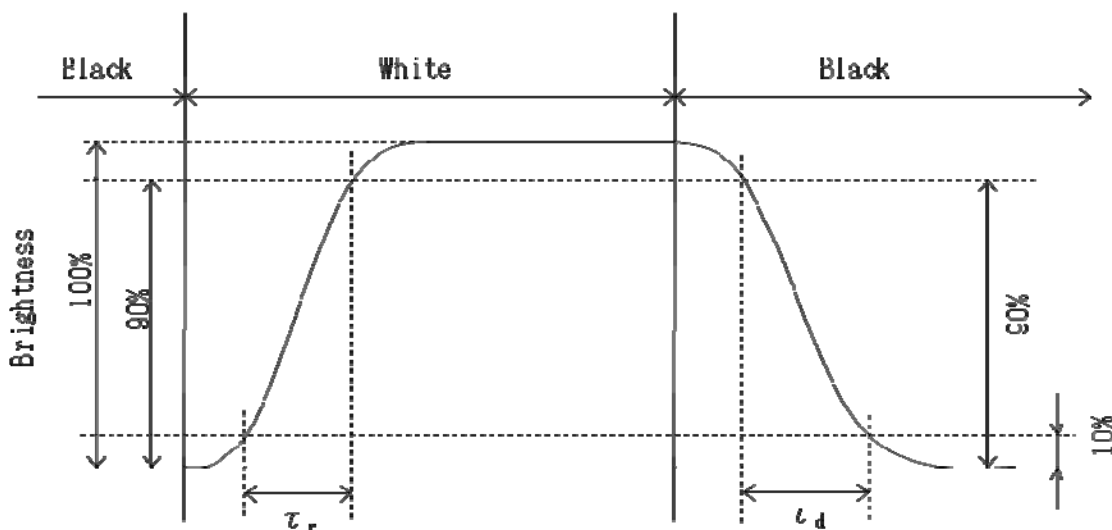

6-3. Definition of viewing angle

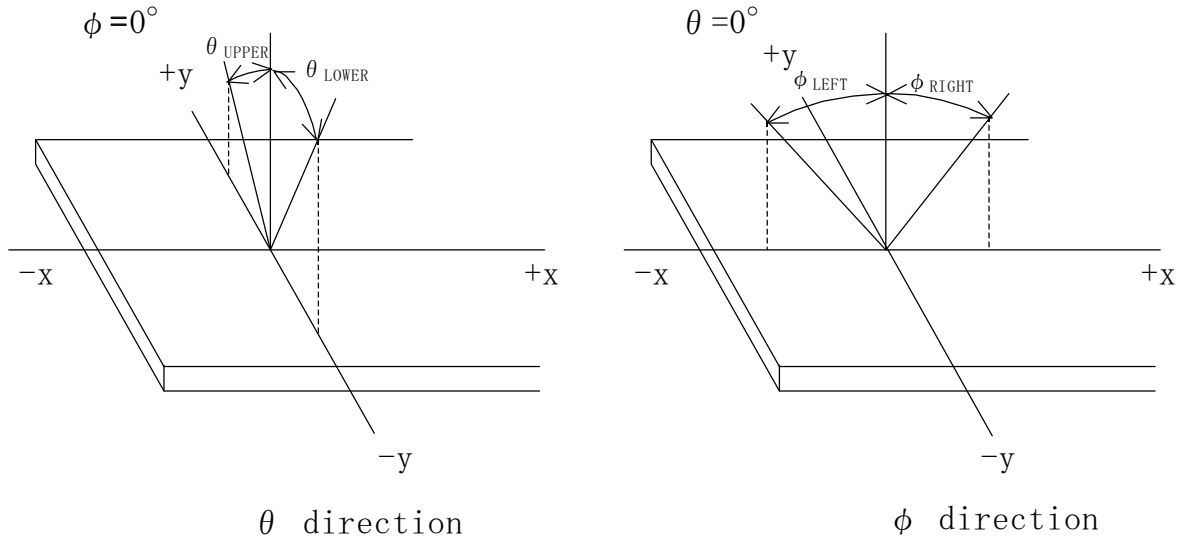

6-4. Brightness measuring points

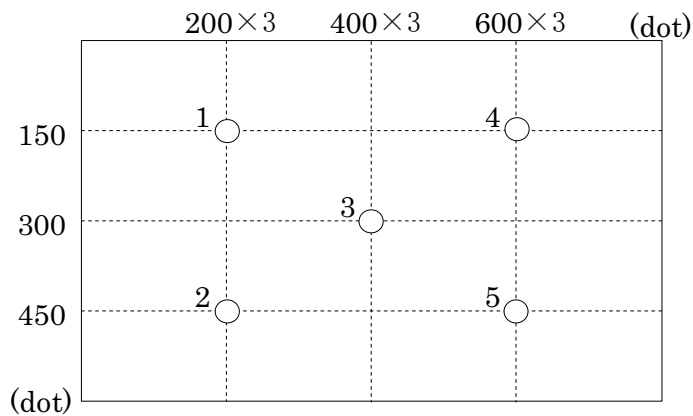

- 1) Rating is defined as the white brightness at center of display screen(3).
- 2) 5 minutes after LED is turned on. (Ambient Temp.=25°C)

7. Interface signals

7-1. Interface signals

No.	Symbol	Description	Note
1	GND	GND	
2	SELLVDS	Mode select signal(LVDS Data mapping)	
3	GND	GND	
4	GND	GND	
5	RxIN3+	LVDS receiver signal CH3(+)	LVDS
6	RxIN3-	LVDS receiver signal CH3(-)	LVDS
7	GND	GND	
8	CK IN+	LVDS receiver signal CK(+)	LVDS
9	CK IN-	LVDS receiver signal CK(-)	LVDS
10	GND	GND	
11	RxIN2+	LVDS receiver signal CH2(+)	LVDS
12	RxIN2-	LVDS receiver signal CH2(-)	LVDS
13	GND	GND	
14	RxIN1+	LVDS receiver signal CH1(+)	LVDS
15	RxIN1-	LVDS receiver signal CH1(-)	LVDS
16	GND	GND	
17	RxIN0+	LVDS receiver signal CH0(+)	LVDS
18	RxIN0-	LVDS receiver signal CH0(-)	LVDS
19	GND	GND	
20	GND	GND	
21	V _{DD}	+3.3V power supply	
22	V _{DD}	+3.3V power supply	
23	GND	GND	
24	BLBRT	PWM signal(Brightness adjustment)	
25	BLEN	ON/OFF terminal voltage	
26	GND	GND	
27	V _{IN}	+12V power supply	
28	V _{IN}	+12V power supply	
29	GND	GND	
30	GND	GND	

LCD connector : FI-X30SSLA-HF (JAE)
 Matching connector : FI-X30HL (JAE)
 : FI-X30HL-T (JAE)
 : FI-X30C2L-NPB (JAE)
 : FI-X30C2L-T-NPB (JAE)

LVDS receiver : Embedded in ASIC
 Matching LVDS transmitter : THC63LVDM83R(THine Electronics) or compatible

7-2. Data mapping(6bit RGB input)

1) Location of SELLVDS (THC63LVDM83R(THine Electronics) or compatible)

Transmitter		2Pin SELLVDS	
Pin No.	Data	= L(GND) or OPEN	= H(3.3V)
51	TA0	—	R0(LSB)
52	TA1	—	R1
54	TA2	—	R2
55	TA3	—	R3
56	TA4	—	R4
3	TA5	—	R5(MSB)
4	TA6	—	G0(LSB)
6	TB0	—	G1
7	TB1	—	G2
11	TB2	—	G3
12	TB3	—	G4
14	TB4	—	G5(MSB)
15	TB5	—	B0(LSB)
19	TB6	—	B1
20	TC0	—	B2
22	TC1	—	B3
23	TC2	—	B4
24	TC3	—	B5(MSB)
27	TC4	—	(HS)
28	TC5	—	(VS)
30	TC6	—	DE
50	TD0	—	GND
2	TD1	—	GND
8	TD2	—	GND
10	TD3	—	GND
16	TD4	—	GND
18	TD5	—	GND
25	TD6	—	GND

SELLVDS=H(3.3V)

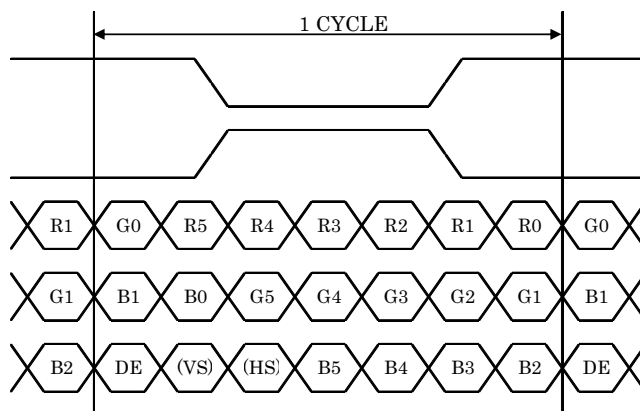

DE : DATA ENABLE

HS : H_{SYNC}

VS : V_{SYNC}

2) Block Diagram

SELLVDS=H(3.3V)

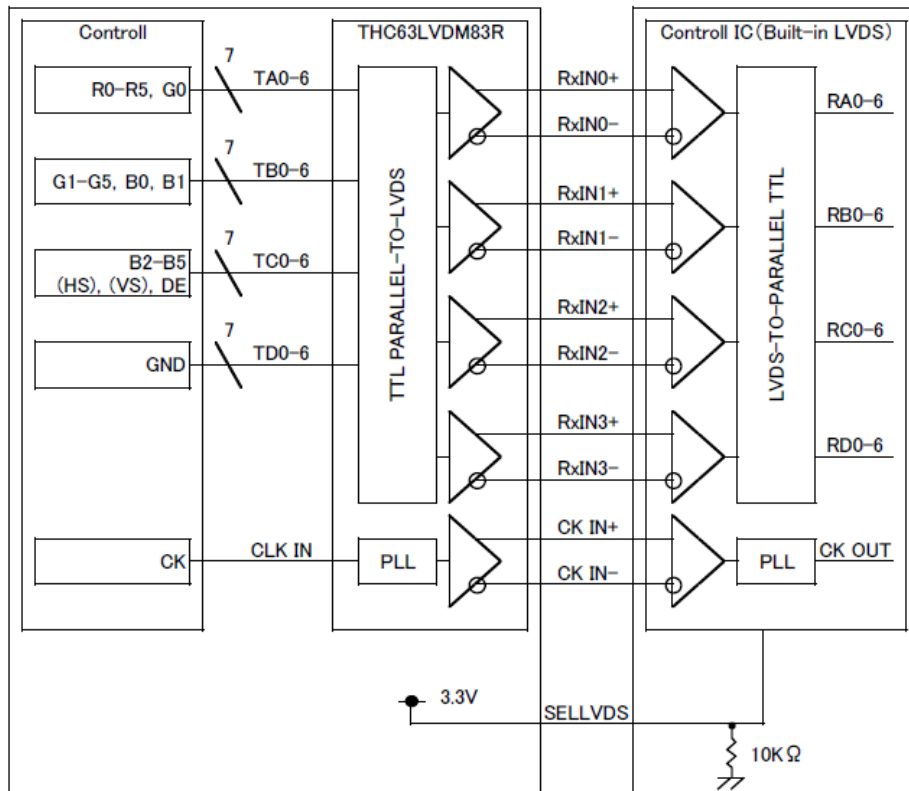

When using “6-bit Transmitter”, please connect the unused channel of the control IC receiver as described in the diagram below.

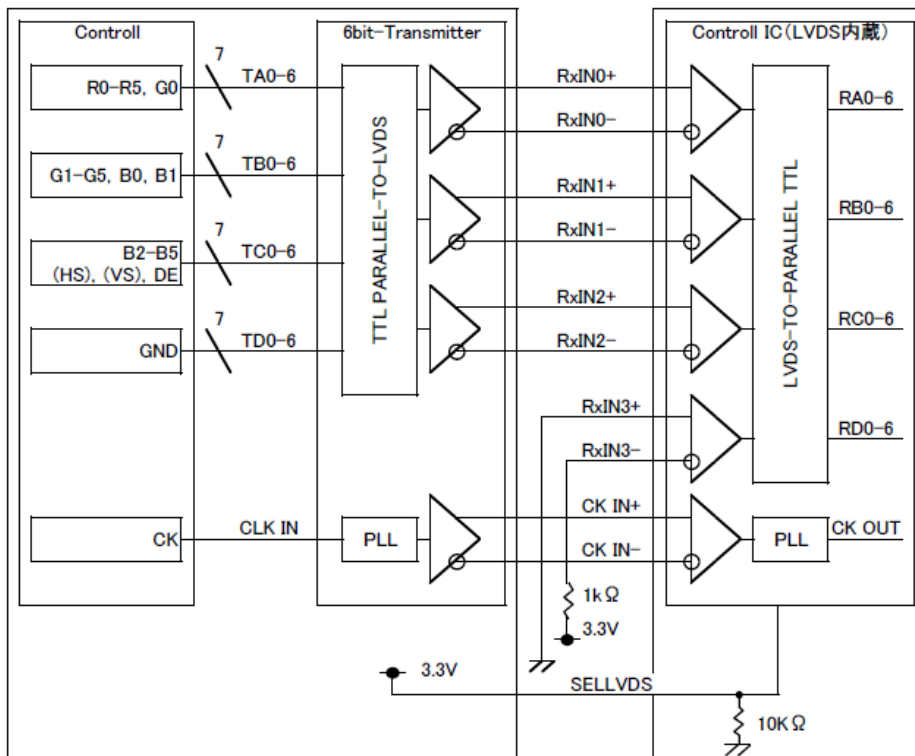

7-3. Data mapping(8bit RGB input)

1) Location of SELLVDS (THC63LVDM83R(THine Electronics) or compatible)

Transmitter		2Pin SELLVDS	
Pin No.	Data	= L(GND) or OPEN	= H(3.3V)
51	TA0	R0(LSB)	R2
52	TA1	R1	R3
54	TA2	R2	R4
55	TA3	R3	R5
56	TA4	R4	R6
3	TA5	R5	R7(MSB)
4	TA6	G0(LSB)	G2
6	TB0	G1	G3
7	TB1	G2	G4
11	TB2	G3	G5
12	TB3	G4	G6
14	TB4	G5	G7(MSB)
15	TB5	B0(LSB)	B2
19	TB6	B1	B3
20	TC0	B2	B4
22	TC1	B3	B5
23	TC2	B4	B6
24	TC3	B5	B7(MSB)
27	TC4	(HS)	(HS)
28	TC5	(VS)	(VS)
30	TC6	DE	DE
50	TD0	R6	R0(LSB)
2	TD1	R7(MSB)	R1
8	TD2	G6	G0(LSB)
10	TD3	G7(MSB)	G1
16	TD4	B6	B0(LSB)
18	TD5	B7(MSB)	B1
25	TD6	(NA)	(NA)

SELLVDS=L(GND) or OPEN

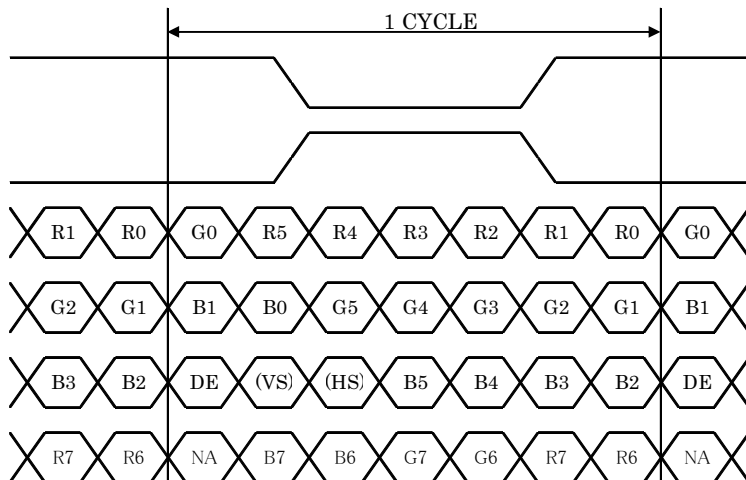

DE : DATA ENABLE

HS : H_{SYNC}

VS : V_{SYNC}

SELLVDS=H(3.3V)

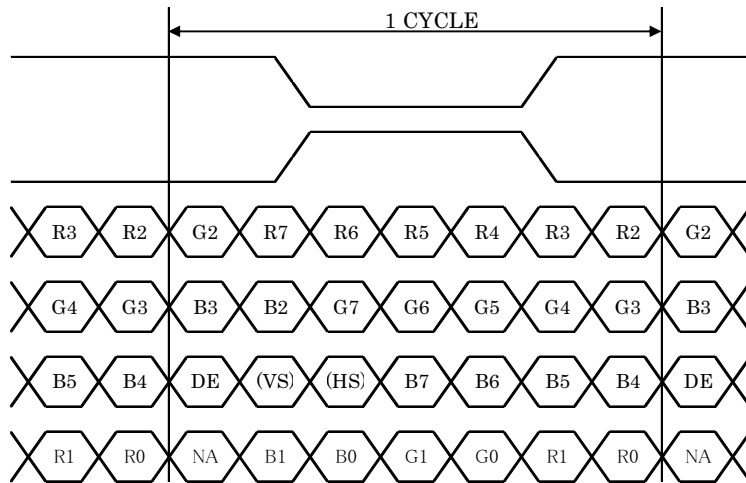

DE : DATA ENABLE

HS : Hsync

VS : Vsync

2) Block Diagram

SELLVDS=L(GND) or OPEN

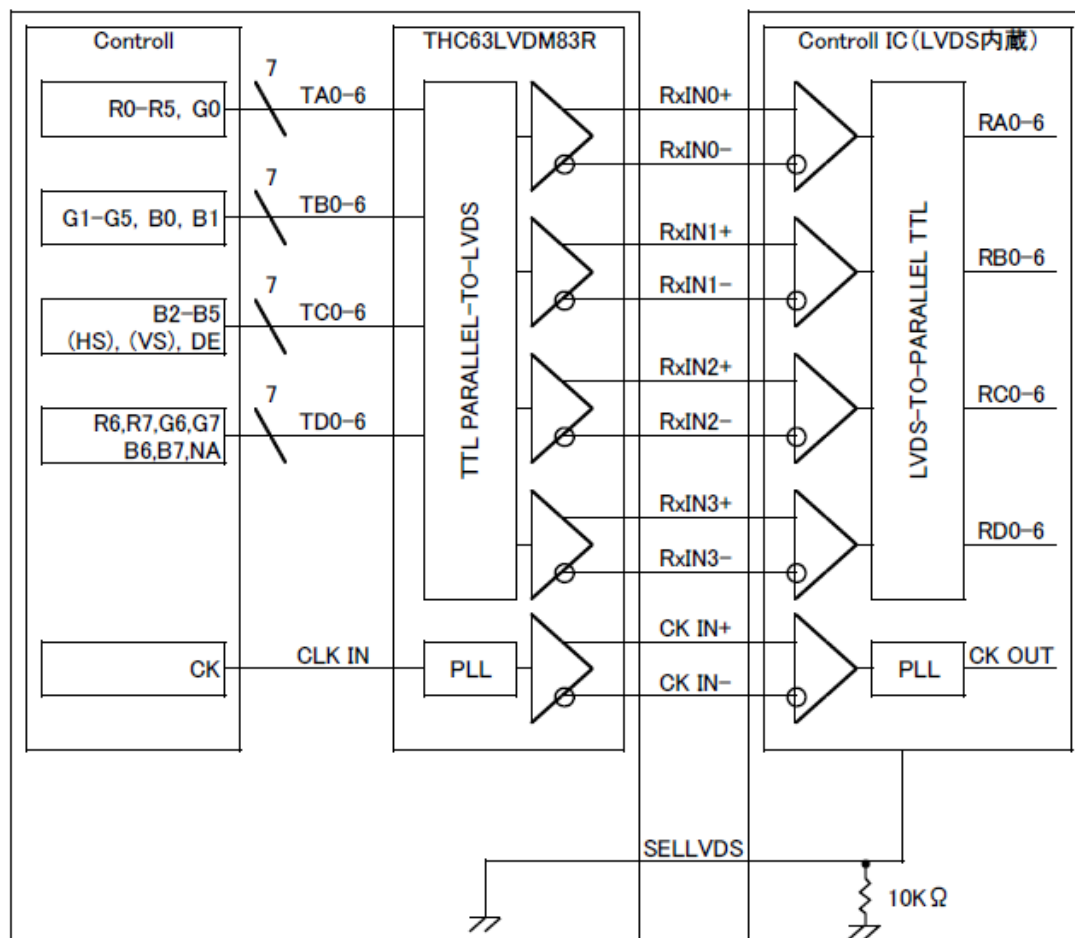

SELLVDS=H(3.3V)

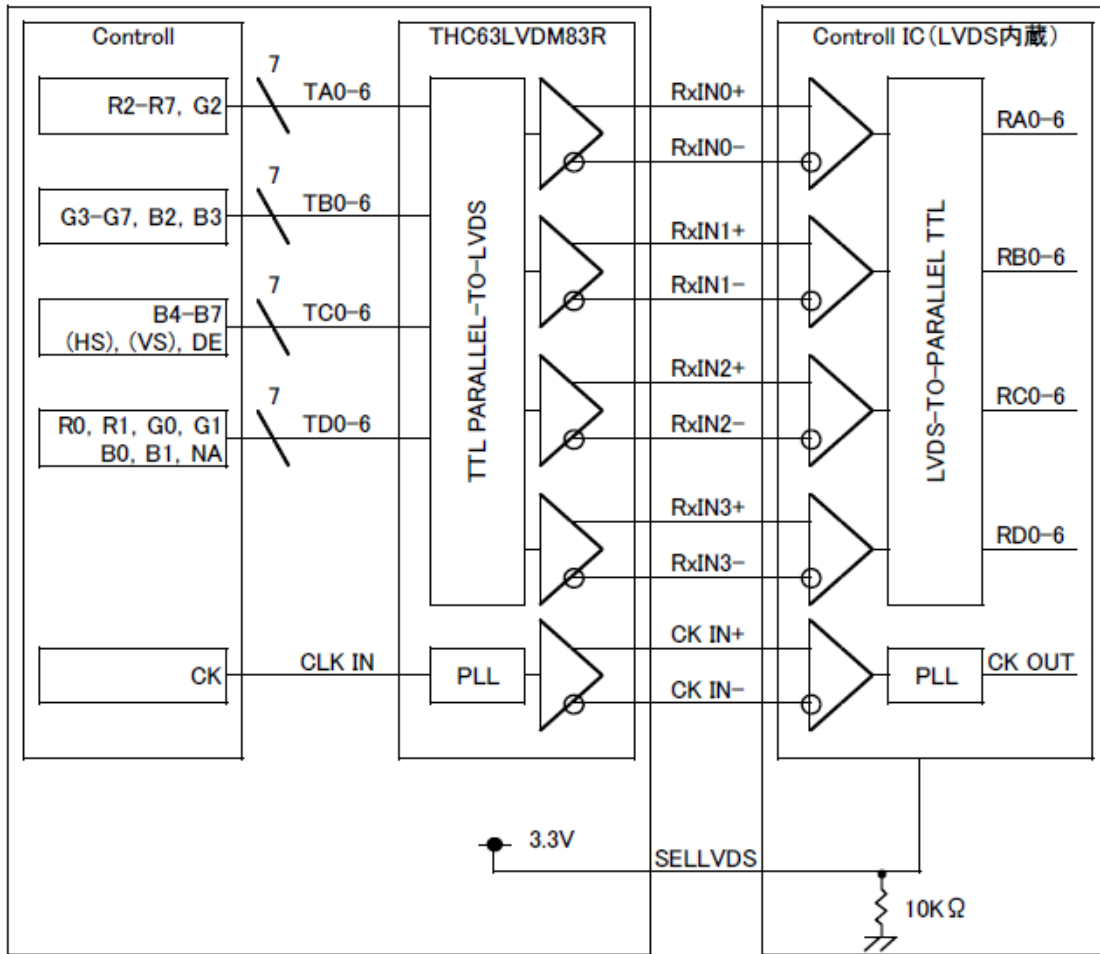

8. Input timing characteristics

8-1. Timing characteristics

Item		Symbol	Min.	Typ.	Max.	Unit	Note
Clock (CK)	Frequency	1/Tc	30	40	48	MHz	
Enable signal (DE)	Horizontal Period	Th	860	1056	1395	Tc	
			24.0	26.4	-	μs	1)
	Horizontal display period	Thd	800			Tc	
	Vertical Period	Tv	610	628	1024	Th	
	Vertical display period	Tvd	600			Th	
Refresh rate		fv	50	60	70	Hz	2)

1) Please set a clock frequency, a vertical dormant period, and the horizontal dormant period so that the Horizontal Period should not reach less than Min. value.

2) If the refresh rate reach less than Min. value, the deterioration of the display quality, flicker etc., may occur.(fv=1/Tv)

Vertical Timing Diagram

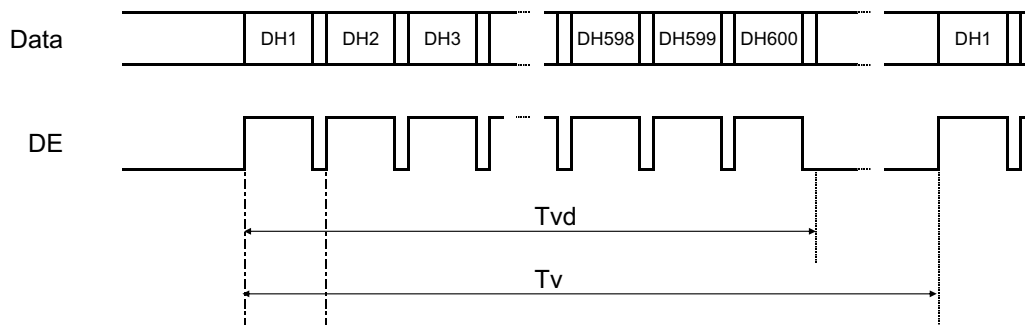

Horizontal Timing Diagram

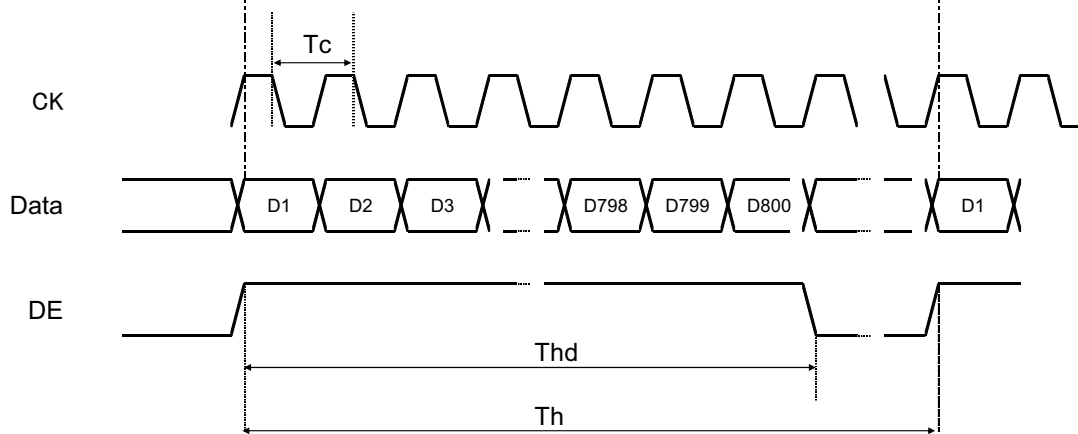

8-2. Input Data Signals and Display position on the screen

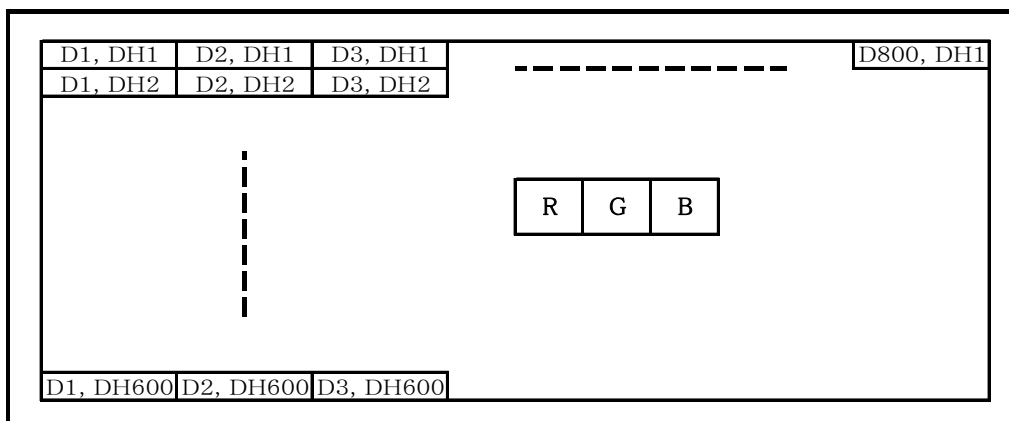

9. Lot number identification

The lot number shall be indicated on the back of the backlight case of each LCD.

TCG084SVLQ*PNN-AN*33 - □□ - □□ - □ MADE IN □□□□□
 ↓↓ ↓ ↓ ↓ ↓
 1 2 3 4 5

No1. - No5. above indicate
 1. Year code
 2. Month code
 3. Date
 4. Version Number
 5. Country of origin (Japan or China)

Year	2014	2015	2016	2017	2018	2019
Code	4	5	6	7	8	9

Month	Jan.	Feb.	Mar.	Apr.	May	Jun.
Code	1	2	3	4	5	6

Month	Jul.	Aug.	Sep.	Oct.	Nov.	Dec.
Code	7	8	9	X	Y	Z

10. Warranty

10-1. Incoming inspection

Please inspect the LCD within one month after your receipt.

10-2. Production warranty

Kyocera display warrants its LCD's for a period of 12 months from the ship date. Kyocera display shall, by mutual agreement, replace or re-work defective LCD's that are shown to be Kyocera display's responsibility.

11. Precautions for use

11-1. Installation of the LCD

- 1) Please ground either of the mounting (screw) holes of LCD, in order to stabilize brightness and display quality.
- 2) A transparent protection plate shall be added to protect the LCD and its polarizer.
- 3) The LCD shall be installed so that there is no pressure on the LSI chips.
- 4) Since this product is wide viewing product, occurrence level of in-plane unevenness by the external stress is different compared to current normal viewing product. So there is a possibility that in-plane unevenness will be occurred by over twist, strain giving by attaching to LCD, and over pressure to touch panel. Please be careful of stress when designing the housing.
- 5) A transparent protection sheet is attached to the polarizer. Please remove the protection film slowly before use, paying attention to static electricity.

11-2. Static electricity

- 1) Since CMOS ICs are mounted directly onto the LCD glass, protection from static electricity is required.
- 2) Workers should use body grounding. Operator should wear ground straps.

11-3. LCD operation

- 1) The LCD shall be operated within the limits specified. Operation at values outside of these limits may shorten life, and/or harm display images.
- 2) Please select the best display pattern based on your evaluation because flicker, lines or nonuniformity or unevenness can be visible depending on display patterns.

11-4. Storage

- 1) The LCD shall be stored within the temperature and humidity limits specified.
Store in a dark area, and protect the LCD from direct sunlight or fluorescent light.
- 2) Always store the LCD so that it is free from external pressure onto it.

11-5. Usage

- 1) **DO NOT** store in a high humidity environment for extended periods. Polarizer degradation bubbles, and/or peeling off of the polarizer may result.
- 2) The front polarizer is easily scratched or damaged. Prevent touching it with any hard material, and from being pushed or rubbed.
- 3) The LCD screen may be cleaned by wiping the screen surface with a soft cloth or cotton pad using a little Ethanol.
- 4) Water may cause damage or discoloration of the polarizer. Clean condensation or moisture from any source immediately.
- 5) Always keep the LCD free from condensation during testing. Condensation may permanently spot or stain the polarizer.
- 6) Do not disassemble LCD because it will result in damage.
- 7) This Kyocera display LCD has been specifically designed for use in general electronic devices, but not for use in a special environment such as usage in an active gas. Hence, when the LCD is supposed to be used in a special environment, evaluate the LCD thoroughly beforehand and do not expose the LCD to chemicals such as an active gas.
- 8) Please do not use solid-base image pattern for long hours because a temporary afterimage may appear. We recommend using screen saver etc. in cases where a solid-base image pattern must be used.
- 9) Liquid crystal may leak when the LCD is broken. Be careful not to let the fluid go into your eyes and mouth. In the case the fluid touches your body; rinse it off right away with water and soap.

12. Reliability test data

Test item	Test condition	Test time	Judgement
High temp. atmosphere	80°C	(240h)	Display function : No defect Display quality : No defect Current consumption : No defect
Low temp. atmosphere	-30°C	(240h)	Display function : No defect Display quality : No defect Current consumption : No defect
High temp. humidity atmosphere	40°C 90% RH	(240h)	Display function : No defect Display quality : No defect Current consumption : No defect
Temp. cycle	-30°C 0.5h R.T. 0.5h 80°C 0.5h	(10cycles)	Display function : No defect Display quality : No defect Current consumption : No defect
High temp. operation	80°C	(500h)	Display function : No defect Display quality : No defect Current consumption : No defect

- 1) Each test item uses a test LCD only once. The tested LCD is not used in any other tests.
- 2) The LCD is tested in circumstances in which there is no condensation.
- 3) The reliability test is not an out-going inspection.
- 4) The result of the reliability test is for your reference purpose only.
The reliability test is conducted only to examine the LCD's capability.

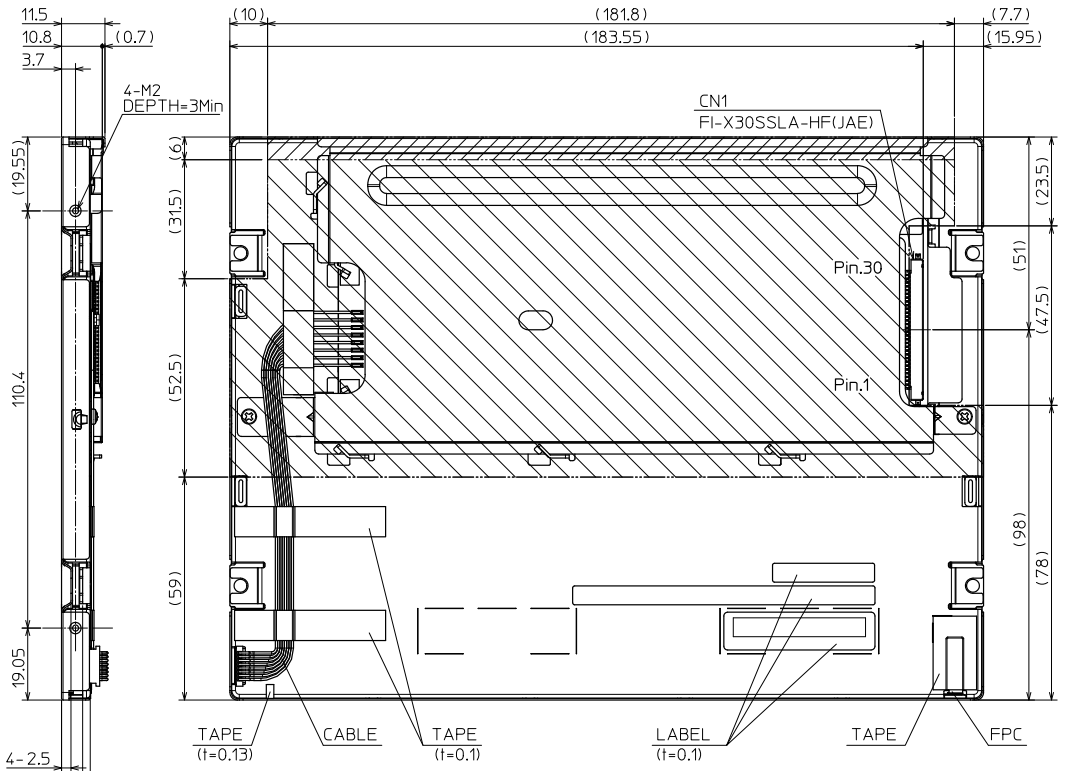
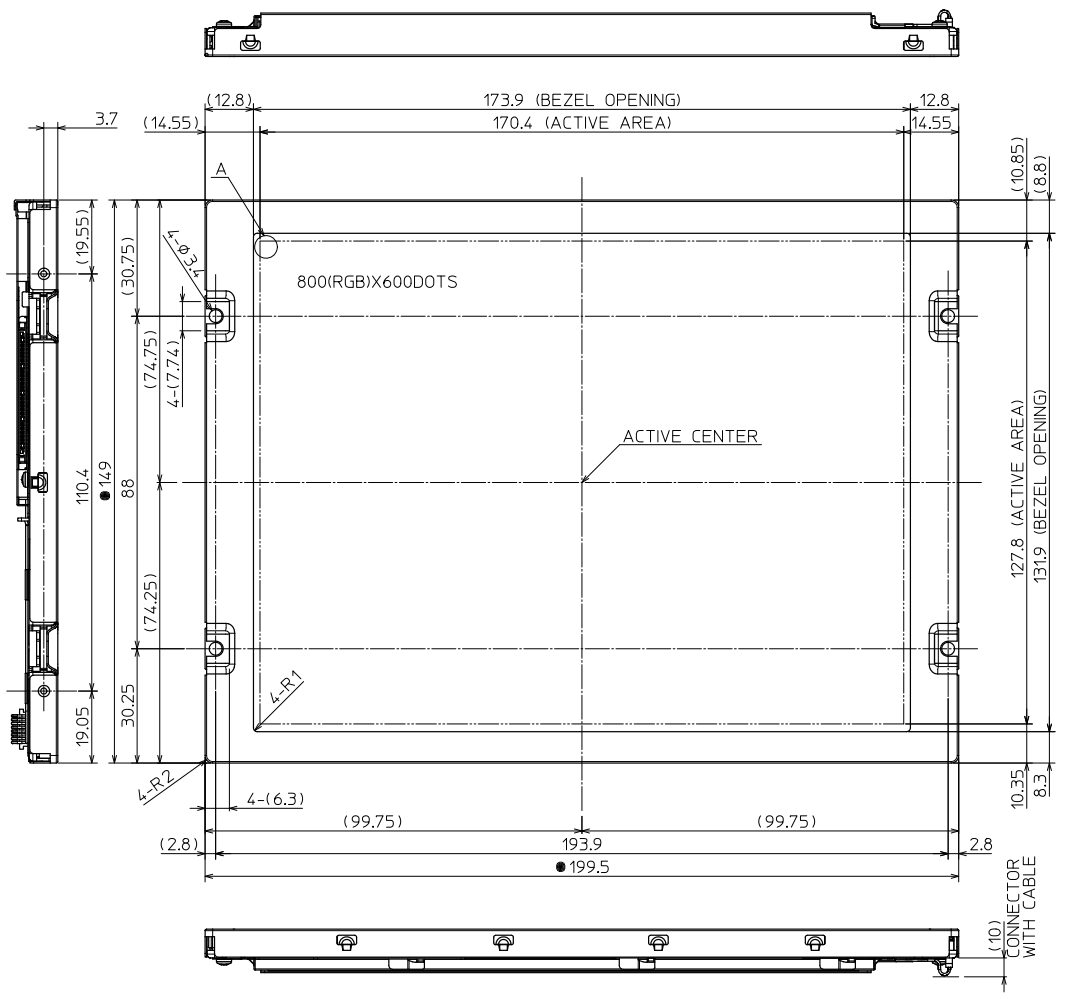

:Projected part is 11.5mm thickness. (厚≠11.5mm)
 :Projected part is 10.8mm thickness. (厚≠10.8mm)



DETAIL A (Dot Size)
(NTS)

TOLERANCE			
MEASURE	A	B	C
L≤16	+0.1	±0.3	±1
16<L≤63	+0.2	±0.5	±1.5
63<L≤250	+0.3	±0.8	±2
250<L≤500	+0.5	±1.2	±3
500<L	+0.8	±2	±4
ANGLE	±1°	±5°	±10°

- Notes
- The dimensions with the mark (●) are controlled as a particular characteristic.
●印を付けた寸法・仕様は、弊社の管理特性の指示を表わす。
 - There is a possibility that in-plane unevenness will be occurred by over twist, stress giving by attaching to LCD, and over pressure to touch panel. Please be careful of stress when designing the housing.
過度な捻り(ひずみ)、LCD固定時の応力発生、タッチパネルでの過度の押し圧によっては、パネル面内にムラが発生することがありますので、筐体設計において、事前に十分確認願います。
 - Tolerance without indication: ±0.5
指示なき公差
 - Max screw length: 3Max.
最長ねじ長さ
 - Max screw torque: **kgf·cm
最大トルク

NAME **TCG084SVLQ*PNN-AN*33**
 DWG NUMBER **121A8071800**

MATERIAL:		FINISH:	
DATE	2013/11/25	THIRD ANGLE PROJECTION	
APPROVED	SASAKURA	SCALE	UNIT
CHECKED	MKATO MKAGEYAMA	1:1	mm
DRAWN	SKURAMOTO	DATE	'13.11.22
TITLE		DIMENSION OUTLINE	
DWG NO(CODE)		T-55786GD084J-LW-AHN	
DWG SIZE		A2	
DWG REV			

Spec No.	TQ3C-8EAF0-E2TAB02-00
Date	January 21, 2014

KYOCERA INSPECTION STANDARD

TYPE : T-55786GD084J-LW-AHN
(TCG084SVLQ*PNN-AN*33)

KYOCERA DISPLAY CORPORATION

Original Issue Date	Designed by : Engineering dept.			Confirmed by : QA dept.	
	Prepared	Checked	Approved	Checked	Approved
January 21, 2014	<i>T. Cudera</i>	<i>S. Ohtaka</i>	<i>M. Fujitani</i>	<i>O. Sato</i>	<i>I. Hamada</i>

Spec No.
TQ3C-8EAF0-E2TAB02-00

Part No.
T-55786GD084J-LW-AHN
(TCG084SVLQ*PNN-AN*33)

Page
-

Revision record

Date		Designed by : Engineering dept.			Confirmed by : QA dept.	
		Prepared	Checked	Approved	Checked	Approved
Rev.No.	Date	Page	Descriptions			

Visuals specification

1) Note

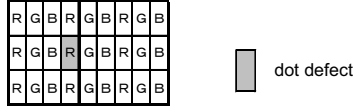
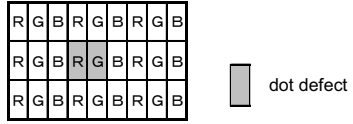
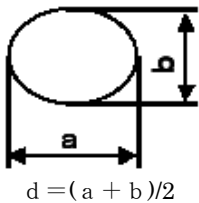
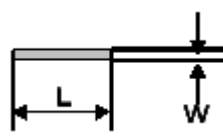
		Note		
General	<p>1. Customer identified anomalies not defined within this inspection standard shall be reviewed by Kyocera display, and an additional standard shall be determined by mutual consent.</p> <p>2. This inspection standard about the image quality shall be applied to any defect within the active area and shall not be applicable to outside of the area.</p> <p>3. Inspection conditions</p> <p>Luminance : 300 ~ 500 Lux min.</p> <p>Inspection distance : 350 mm.</p> <p>Temperature : Approximate 25°C</p> <p>Direction : Normal to the LCD panel ± 10° horizontal and vertical</p>			
Definition of inspection item	Dot defect	Bright dot defect	<p>The dot is constantly “on” when power applied to the LCD, even when all “Black” data sent to the screen.</p> <p>Inspection tool: 5% Transparency neutral density filter.</p> <p>Count dot: If the dot is visible through the filter.</p> <p>Don't count dot: If the dot is not visible through the filter.</p> 	
		Black dot defect	<p>The dot is constantly “off” when power applied to the LCD, even when all “White” data sent to the screen.</p>	
		Adjacent dot	<p>Adjacent dot defect is defined as two or more bright dot defects or black dot defects.</p> 	
	External inspection	Bubble, Scratch, Foreign particle (Polarizer, Cell, Backlight)	Visible operating (all pixels “Black” or “White”) and non operating.	
		Appearance inspection	Does not satisfy the value at the spec.	
Definition of size	Definition of circle size	Definition of linear size		
	 <p>$d = (a + b) / 2$</p>			

2) Standard

Defect Type		Limit	
Visual defect	Scratch	$0.01 \text{ mm} < W \leq 0.05 \text{ mm}$	$N \leq 4$
		$L \leq 10 \text{ mm}$	
		$0.01 \text{ mm} < W$ $10 \text{ mm} < L$	$N = 0$
		$0.05 \text{ mm} < W$	$N = 0$
	Dent	$0.2 \text{ mm} < \Phi \leq 0.4 \text{ mm}$	$N \leq 4$
		$0.4 \text{ mm} < \Phi$	$N = 0$
	Black spot	$0.2 \text{ mm} < \Phi \leq 0.4 \text{ mm}$	$N \leq 5$
	Bubble	$0.4 \text{ mm} < \Phi$	$N = 0$
	Lint	$L \leq 3 \text{ mm}$	$N \leq 4$
		$W \leq 0.1 \text{ mm}$	
$3 \text{ mm} \leq L$		$N = 0$	
$W \leq 0.1 \text{ mm}$			
	$0.1 \text{ mm} < W$	According to Black spot	
Electrical defect	Bright dot	$N \leq 5$	
	Dark dot	$N \leq 5$	
	Total dot	$N \leq 8$	
	Two adjacent dot		
	Bright dot	$\leq 2 \text{ pairs}$	
	Dark dot	$\leq 2 \text{ pairs}$	
	Three or more adjacent dot	Not allowed	
Line defect	Not allowed		