

AVERY DENNISON MARKETING SPECIFICATION

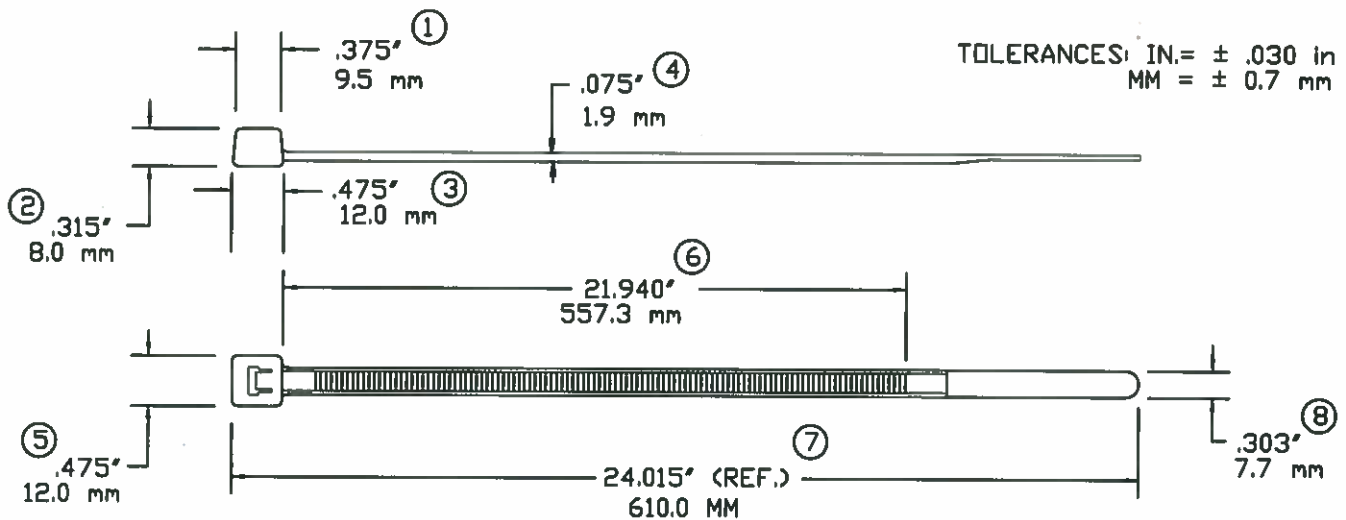

NOT TO SCALE

LOOP TENSILE STRENGTH:	120 LBF / 534N MINIMUM PER AS-23190
OPERATING TEMPERATURE:	-40°F(-40°C) TO 185°F(85°C)
MIN. INSTALLATION TEMP:	32°F(0°C)
MATERIAL:	NYLON 6/6
WEIGHT:	.3224 OZ. / 9.1 GRAMS
MILITARY STANDARD:	MS-3367-3-9
BUNDLE DIAMETER:	Ø.250"/4.76mm TO Ø7.0"/177.8mm
TOOL TENSION SETTING:	6-8 ON HEAVY DUTY TOOL
PACKAGED IN:	50/BAG, 1,000/CASE

NOTE: THESE CABLE TIES ARE PLENUM RATED AND HAVE A FLAMMABILITY RATING OF V-2.



FASTENER DIVISION
 FITCHBURG, MA 01420 U.S.A.
 TEL. 1-800-225-5913
 FAX. 1-800-848-2169

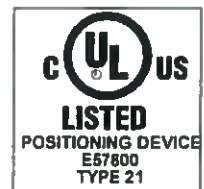

DESCRIPTION: <p style="text-align: center;">24" / 610mm, CABLE TIE, HEAVY DUTY NATURAL</p>	APPROVAL: <p style="text-align: center;"><i>L. Boyle 9-15-2015</i></p>	
	<table border="1" style="width: 100%; border-collapse: collapse;"> <tr> <td style="width: 70%;">STOCK NO. 10612-0</td> <td style="width: 30%;">REV H</td> </tr> </table>	STOCK NO. 10612-0
STOCK NO. 10612-0	REV H	