

NHD-16032AZ-FL-YBW

Graphic Liquid Crystal Display Module

NHD- Newhaven Display
16032- 160 x 32 Pixels
AZ- Model
F- Transflective
L- Yellow/Green LED Backlight
Y- STN- Yellow/Green
B- 6:00 Optimal View
W- Wide Temperature
RoHS Compliant

Newhaven Display International, Inc.

2661 Galvin Ct.

Elgin IL, 60124

Ph: 847-844-8795

Fax: 847-844-8796

www.newhavendisplay.com

nhtech@newhavendisplay.com

nhsales@newhavendisplay.com

Document Revision History

Revision	Date	Description	Changed by
0	2/28/2009	Initial Release	-
1	4/9/2010	User guide reformat	BE
2	5/7/2010	Block diagram/initialization update	BE
3	1/25/2012	Mechanical drawing updated	AK
4	6/7/2013	Controller information added	AK
5	9/22/16	Mechanical Drawing, Electrical & Optical Char. Updated	SB
6	5/10/17	Mechanical Drawing Updated	SB

Functions and Features

- 160x32 pixels
- Built-in ST7920-0B Controller
- +5.0V power supply
- 1/32 duty, 1/9 bias
- RoHS Compliant

Mechanical Drawing

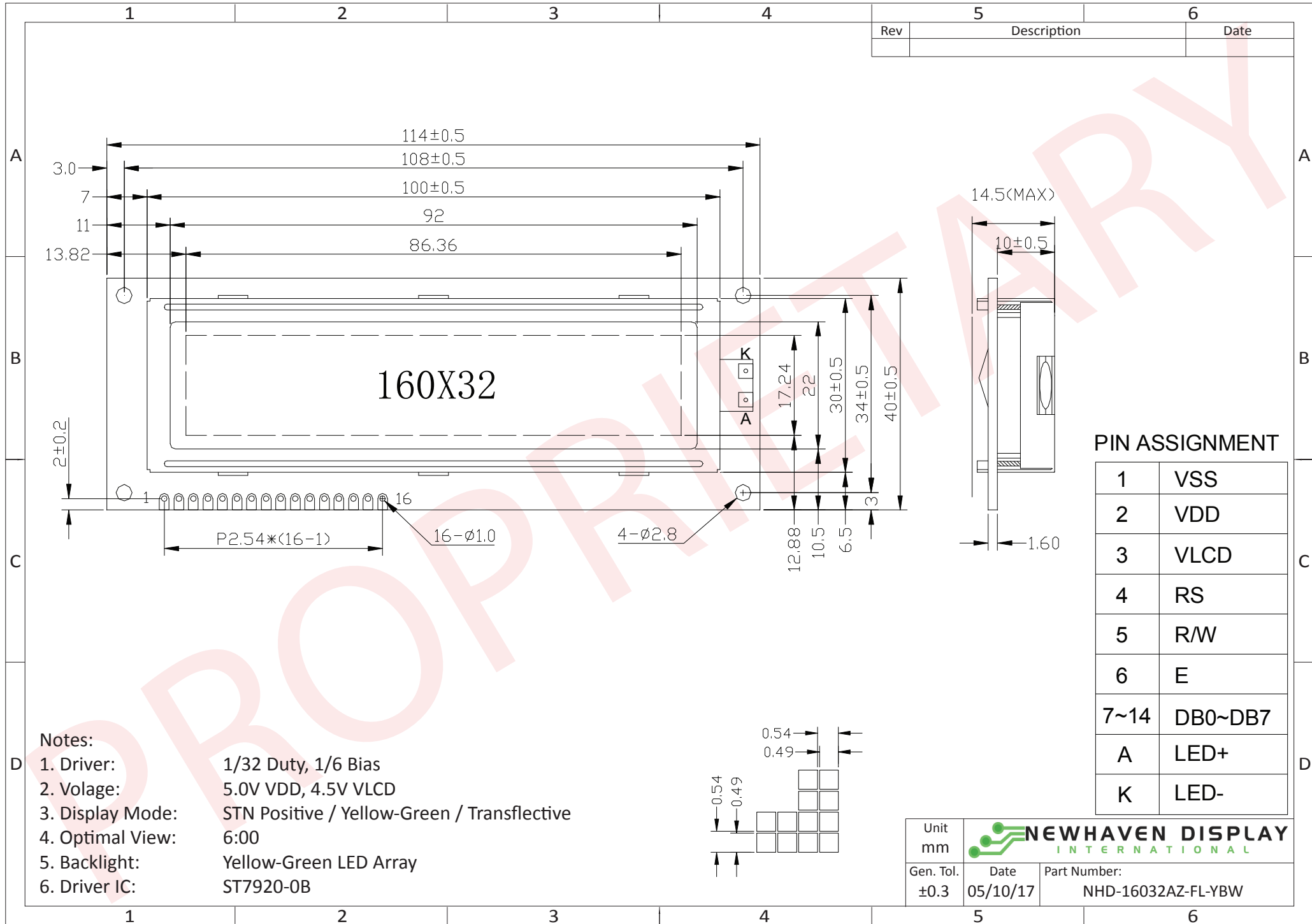

Unit mm		
Gen. Tol. ± 0.3	Date 05/10/17	Part Number: NHD-16032AZ-FL-YBW

Pin Description and Wiring Diagram

Pin No.	Symbol	External Connection	Function Description
1	V _{SS}	Power Supply	Ground
2	V _{DD}	Power Supply	Power supply for LCD and Logic (+5.0V)
3	NC	-	No Connect
4	RS	MPU	Register Select signal: 1=Data, 0=Instruction
5	R/W	MPU	Read/Write select signal, R/W=1: Read R/W: =0: Write
6	E	MPU	Operation Enable signal. Falling edge triggered.
7-14	DB0-DB7	MPU	8-Bit Bi-directional data bus
15	LED+	Power Supply	Backlight Anode (150 mA @ 5V)
16	LED-	Power Supply	Backlight Cathode (Ground)

Recommended LCD connector: 2.54mm pitch pins

Backlight connector: - Mates with: -

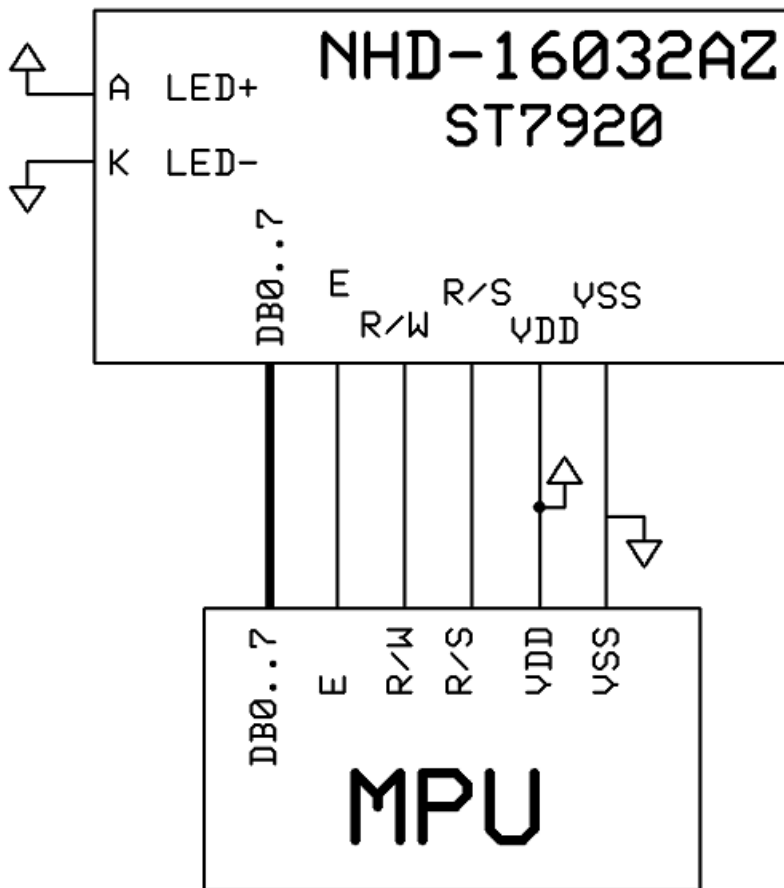

Electrical Characteristics

Item	Symbol	Condition	Min.	Typ.	Max.	Unit
Operating Temperature Range	T_{OP}	Absolute Max	-20	-	+70	°C
Storage Temperature Range	T_{ST}	Absolute Max	-30	-	+80	°C
Supply Voltage	V_{DD}	-	4.5	5.0	5.5	V
Supply Current	I_{DD}	$V_{DD} = 5.0V$ $T_{OP} = 25^{\circ}C$	1.0	1.5	2.5	mA
Supply for LCD (contrast)	V_{LCD}		4.3	4.5	4.7	-
"H" Level input	V_{IH}	-	$0.7 * V_{DD}$	-	V_{DD}	V
"L" Level input	V_{IL}	-	V_{SS}	-	0.6	V
"H" Level output	V_{OH}	-	$0.8 * V_{DD}$	-	V_{DD}	V
"L" Level output	V_{OL}	-	V_{SS}	-	0.4	V
Backlight Supply Current	I_{LED}	-	-	150	180	mA
Backlight Supply Voltage	V_{LED}	$I_{LED} = 150mA$	4.7	5.0	5.3	V

Optical Characteristics

Item	Symbol	Condition	Min.	Typ.	Max.	Unit	
Optimal Viewing Angles	Top	$\phi Y+$	$CR \geq 2$	-	40	-	°
	Bottom	$\phi Y-$		-	60	-	°
	Left	$\theta X-$		-	60	-	°
	Right	$\theta X+$		-	60	-	°
Contrast Ratio	CR	-	2	5	-	-	
Response Time	Rise	T_R	$T_{OP} = 25^{\circ}C$	-	150	250	ms
	Fall	T_F		-	200	300	ms

Controller Information

Built-in ST7920-0B.

Please download specification at http://www.newhavendisplay.com/app_notes/ST7920.pdf

Table of Commands

Instruction Set 1: (RE=0: Basic Instruction)

Inst.	Code										Description	Exec time (540KHZ)
	RS	RW	DB7	DB6	DB5	DB4	DB3	DB2	DB1	DB0		
Display Clear	0	0	0	0	0	0	0	0	0	1	Fill DDRAM with "20H" and set DDRAM address counter (AC) to "00H".	1.6 ms
Return Home	0	0	0	0	0	0	0	0	1	X	Set DDRAM address counter (AC) to "00H", and put cursor to origin ; the content of DDRAM are not changed	72 us
Entry Mode Set	0	0	0	0	0	0	0	1	I/D	S	Set cursor position and display shift when doing write or read operation	72 us
Display Control	0	0	0	0	0	0	1	D	C	B	D=1: Display ON C=1: Cursor ON B=1: Character Blink ON	72 us
Cursor Display Control	0	0	0	0	0	1	S/C	R/L	X	X	Cursor position and display shift control; the content of DDRAM are not changed	72 us
Function Set	0	0	0	0	1	DL	X	0 RE	X	X	DL=1 8-bit interface DL=0 4-bit interface RE=1: extended instruction RE=0: basic instruction	72 us
Set CGRAM Address.	0	0	0	1	AC5	AC4	AC3	AC2	AC1	AC0	Set CGRAM address to address counter (AC) Make sure that in extended instruction SR=0 (scroll or RAM address select)	72 us
Set DDRAM Address.	0	0	1	0 AC6	AC5	AC4	AC3	AC2	AC1	AC0	Set DDRAM address to address counter (AC) AC6 is fixed to 0	72 us
Read Busy Flag (BF) & AC.	0	1	BF	AC6	AC5	AC4	AC3	AC2	AC1	AC0	Read busy flag (BF) for completion of internal operation, also Read out the value of address counter (AC)	0 us
Write RAM	1	0	D7	D6	D5	D4	D3	D2	D1	D0	Write data to internal RAM (DDRAM/CGRAM/GDRAM)	72 us
Read RAM	1	1	D7	D6	D5	D4	D3	D2	D1	D0	Read data from internal RAM (DDRAM/CGRAM/GDRAM)	72 us

Instruction set 2: (RE=1: extended instruction)

Inst.	Code										Description	Exec time (540KHZ)
	RS	RW	DB7	DB6	DB5	DB4	DB3	DB2	DB1	DB0		
Standby	0	0	0	0	0	0	0	0	0	1	Enter standby mode, any other instruction can terminate. COM1...32 are halted.	72 us
Scroll or RAM Address. Select	0	0	0	0	0	0	0	0	0	1 SR	SR=1: enable vertical scroll position SR=0: enable CGRAM address (basic instruction)	72 us
Reverse (by line)	0	0	0	0	0	0	0	0	1 R1	R0	Select 1 out of 4 line (in DDRAM) and decide whether to reverse the display by toggling this instruction R1,R0 initial value is 0,0	72 us
Extended Function Set	0	0	0	0	1	DL	X	1 RE	G	0	DL=1 :8-bit interface DL=0 :4-bit interface RE=1: extended instruction set RE=0: basic instruction set G=1 :graphic display ON G=0 :graphic display OFF	72 us
Set Scroll Address	0	0	0	1	AC5	AC4	AC3	AC2	AC1	AC0	SR=1: AC5~AC0 the address of vertical scroll	72 us
Set Graphic Display RAM Address	0	0	1	0 0	0 AC5	0 AC4	AC3 AC3	AC2 AC2	AC1 AC1	AC0 AC0	Set GDRAM address to address counter (AC) Set the vertical address first and followed the horizontal address by consecutive writings Vertical address range: AC5...AC0 Horizontal address range: AC3...AC0	72 us

Timing Characteristics

MPU write data to ST7920

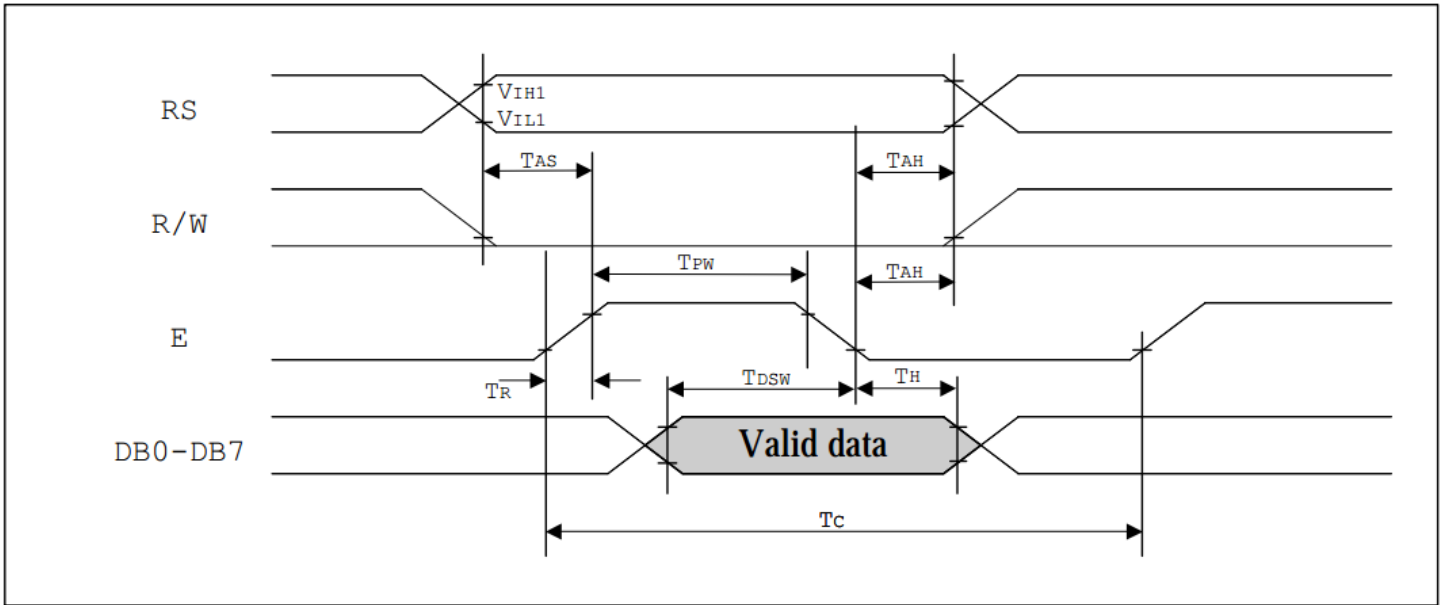

<i>Write Mode (Writing data from MPU to ST7920)</i>						
T_C	Enable Cycle Time	Pin E	1200	-	-	ns
T_{PW}	Enable Pulse Width	Pin E	140	-	-	ns
T_R, T_F	Enable Rise/Fall Time	Pin E	-	-	25	ns
T_{AS}	Address Setup Time	Pins: RS,RW,E	10	-	-	ns
T_{AH}	Address Hold Time	Pins: RS,RW,E	20	-	-	ns
T_{DSW}	Data Setup Time	Pins: DB0 - DB7	40	-	-	ns
T_H	Data Hold Time	Pins: DB0 - DB7	20	-	-	ns

MPU read data from ST7920

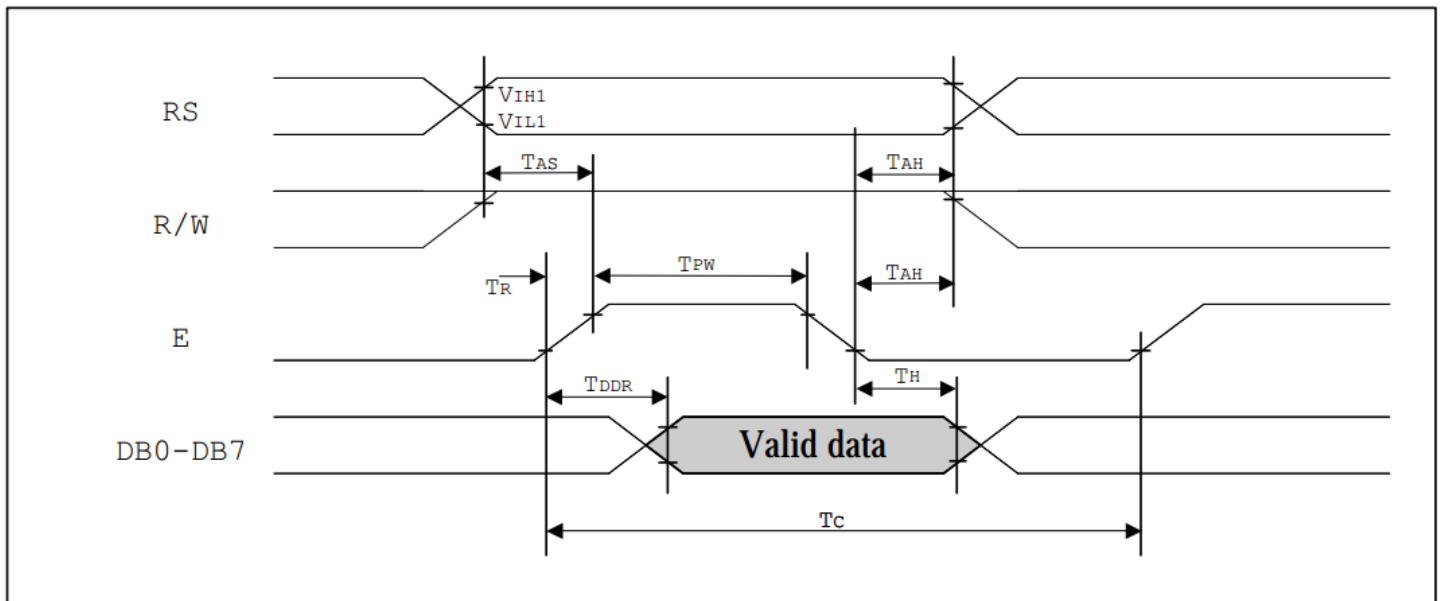

Read Mode (Reading Data from ST7920 to MPU)						
T_C	Enable Cycle Time	Pin E	1200	-	-	ns
T_{PW}	Enable Pulse Width	Pin E	140	-	-	ns
T_{R,T_F}	Enable Rise/Fall Time	Pin E	-	-	25	ns
T_{AS}	Address Setup Time	Pins: RS,RW,E	10	-	-	ns
T_{AH}	Address Hold Time	Pins: RS,RW,E	20	-	-	ns
T_{DDR}	Data Delay Time	Pins: DB0 - DB7	-	-	100	ns
T_H	Data Hold Time	Pins: DB0 - DB7	20	-	-	ns

Built-in Font Table

Please see: http://www.newhavendisplay.com/app_notes/ST7920-0B_font.pdf

Example Initialization Program

```
//-----  
#include <REG52.H>  
#include "AL.h"  
sbit ID = P3^0;  
sbit RW = P3^7;  
sbit E = P3^4;  
  
//-----  
void Init()  
{  
    Wcom(0x38);  
    Wcom(0x0C);  
    Wcom(0x06);  
    Wcom(0x02);  
    Wcom(0x01);  
    delay(10);  
    Row = 0x80;  
    for(Counthi = 1; Counthi <=32; Counthi++)  
    {  
        Wcom(0x3E);  
        Wcom(Row);  
        Wcom(0x80);  
        for(Count = 1; Count <=40; Count++)  
        {  
            Wdata(0x00);  
        }  
        Row++;  
    }  
}  
  
//-----  
void Wcom(char i)  
{  
    P1 = i;  
    ID = 0;  
    RW = 0;  
    E = 1;  
    delay(1);  
    E = 0;  
}  
  
//-----  
void Wdata(char i)  
{  
    P1 = i;  
    ID = 1;  
    RW = 0;  
    E = 1;  
    delay(1);  
    E = 0;  
}  
  
//-----
```

Quality Information

Test Item	Content of Test	Test Condition	Note
High Temperature storage	Endurance test applying the high storage temperature for a long time.	+80°C , 48hrs	2
Low Temperature storage	Endurance test applying the low storage temperature for a long time.	-30°C , 48hrs	1,2
High Temperature Operation	Endurance test applying the electric stress (voltage & current) and the high thermal stress for a long time.	+70°C , 48hrs	2
Low Temperature Operation	Endurance test applying the electric stress (voltage & current) and the low thermal stress for a long time.	-20°C , 48hrs	1,2
High Temperature / Humidity Operation	Endurance test applying the electric stress (voltage & current) and the high thermal with high humidity stress for a long time.	+40°C , 90% RH , 48hrs	1,2
Thermal Shock resistance	Endurance test applying the electric stress (voltage & current) during a cycle of low and high thermal stress.	0°C,30min -> 25°C,5min -> 50°C,30min = 1 cycle 10 cycles	
Vibration test	Endurance test applying vibration to simulate transportation and use.	10-55Hz , 15mm amplitude. 60 sec in each of 3 directions X,Y,Z For 15 minutes	3
Static electricity test	Endurance test applying electric static discharge.	VS=800V, RS=1.5kΩ, CS=100pF One time	

Note 1: No condensation to be observed.

Note 2: Conducted after 4 hours of storage at 25°C, 0%RH.

Note 3: Test performed on product itself, not inside a container.

Precautions for using LCDs/LCMs

See Precautions at www.newhavendisplay.com/specs/precautions.pdf

Warranty Information and Terms & Conditions

http://www.newhavendisplay.com/index.php?main_page=terms