

Infrared Light Emitting Diode

OP205CL



Features:

- High power GaAIAs
- Narrow beam angle—near parallel beam
- 875 nm wavelength
- TO-46 package
- Wide operating temperature range



Description:

The **OP205CL** is a high efficiency GaAIAs infrared LED mounted in a TO-46 metal can package. The device features a special dome lens that allows a very narrow beam angle. The result is a near parallel beam that is useful in applications that require a collimated light source with a uniform intensity pattern.

OP205CL LED is mechanically and spectrally matched to OP800 series phototransistors.

Applications:

- Optical encoders
- Triangulation sensors
- Long distance sensing

Ordering Information			
Part Number	LED Peak Wavelength	Total Beam Angle	Lead Length
OP205CL	875 nm	10°	34mm

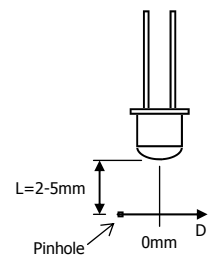
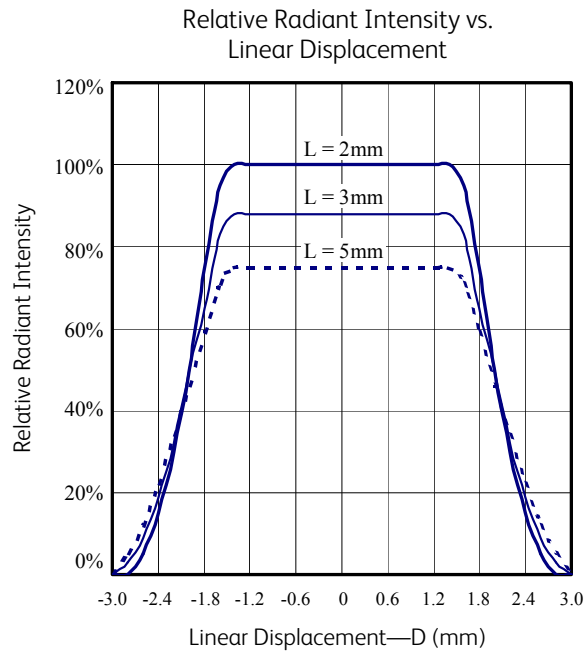
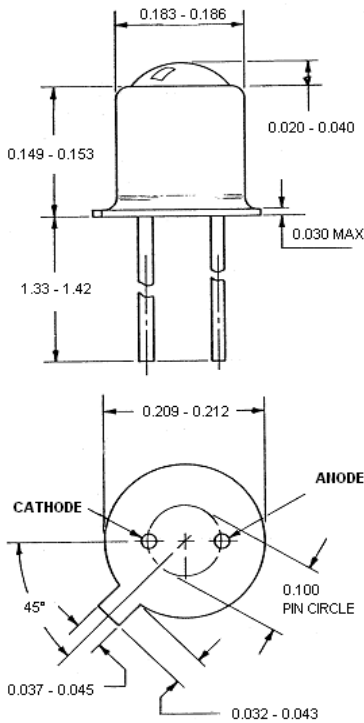

General Note
TT Electronics reserves the right to make changes in product specification without notice or liability. All information is subject to TT Electronics' own data and is considered accurate at time of going to print.

OPTEK Technology, Inc.
1645 Wallace Drive, Carrollton, TX 75006 | Ph: +1 972 323 2200
www.optekinc.com | www.ttelectronics.com

Electrical Specifications

Absolute Maximum Ratings ($T_A = 25^\circ\text{C}$ unless otherwise noted)	
Storage Temperature Range	-40°C to $+125^\circ\text{C}$
Operating Temperature Range	-40°C to $+100^\circ\text{C}$
Lead Soldering Temperature	$260^\circ\text{C}^{(1)}$
Reverse Voltage	3.0 V
Continuous Forward Current	50 mA
Power Dissipation	160 mW ⁽²⁾

Electrical Characteristics ($T_A = 25^\circ\text{C}$ unless otherwise noted)						
SYMBOL	PARAMETER	MIN	TYP	MAX	UNITS	TEST CONDITIONS
P_O	Radiant Intensity	8.5	12.0	-	mW	$I_F = 50\text{mA}^{(3)}$
V_F	Forward Voltage	-	-	2.0	V	$I_F = 50\text{mA}$
I_R	Reverse Current	-	-	10	μA	$V_R = 3.0\text{V}$
λ_p	Peak Emission Wavelength	-	875	-	nm	$I_F = 20\text{mA}$
Θ_{HP}	Total Emission Angle at Half Power Points	-	6	10	Deg.	$I_F = 20\text{mA}$

Notes:

- Solder time less than 5 seconds at temperature extreme.
- De-rate linearly at $2.17\text{ mW}/^\circ\text{C}$ above 25°C .
- Total Optical Power (P_O) is measured by OPTEK Technology equipment.

