

SPECIFICATIONS:

NUMBER OF PHASES: 2	ROTOR INERTIA: 38 g-cm ² (0.21 oz-in ²) NOM
STEPS PER REVOLUTION: 400	DETENT TORQUE: 12 mNm (1.7 oz-in) MIN
STEP ANGLE: 0.9°	BEARINGS: 625ZZ
STEP TO STEP ACCURACY: ±0.045°	INSULATION CLASS: B
POSITIONAL ACCURACY: ±5%	HYSTERESIS: N/A%
SHAFT RUNOUT: 0.03 mm T.I.R. MAX	TEMP. RISE: 80 °C MAX.
RADIAL PLAY: 0.02 mm MAX (.5KG RADIAL LOAD)	OPERATING TEMP. RANGE: -20 TO +50 °C
END PLAY: 0.08 mm MAX (.5KG AXIAL LOAD)	STORAGE TEMP. RANGE: -30 TO +70 °C
MAXIMUM RADIAL LOAD: 21N (4.72lb)	RELATIVE HUMIDITY RANGE: 15 TO 85 %
MAXIMUM AXIAL LOAD: 10N (2.25lb)	WEIGHT: 0.23 kg (0.51 lb)

	[7]	[8]	[1]	[1]
CONNECTION	RESISTANCE PER PHASE (ohm ±10%)	INDUCTANCE PER PHASE (mH ±20%)	RATED CURRENT (amp)	HOLDING TORQUE (Nm MIN)
BI-POLAR SERIES	20	23	0.5	0.22

NOTES, UNLESS OTHERWISE SPECIFIED:

- [1] MEASUREMENTS MADE AT RATED CURRENT IN EACH PHASE.
- [2] BETWEEN ANY TWO ADJACENT FULL STEP POSITIONS.
- [3] MAXIMUM ERROR IN 360°.
- 4. HIPOT 500 VAC, 60 Hz FOR ONE MINUTE.
- 5. LEADS: 4, AWG 26, 7 STRAND MIN., UL AND CSA APPROVED, UL 1007
- 6. INSULATION RESISTANCE: 100 MEGOHMS MIN AT 500 VDC.
- [7] AS MEASURED ACROSS EACH PHASE.
- [8] AS MEASURED ACROSS EACH PHASE USING AN A.C. INDUCTANCE BRIDGE AT 1 kHz.
- [9] AS MEASURED BY THE CHANGE IN RESISTANCE METHOD, WITH RATED CURRENT APPLIED TO 2 PHASES; WITH MOTOR AT REST.
- [10] ADD "D" TO END OF PART NUMBER IF DOUBLE SHAFT IS REQUIRED. ENCODER HOLES INCLUDED WITH REAR SHAFT VERSION ONLY.
- 11. ROTOR & STATOR LAMINATED CONSTRUCTION.
- 12. THIS MOTOR TO BE MANUFACTURED IN COMPLIANCE WITH EU DIRECTIVE "ROHS 2002/95/EC".
- [13] MOTOR LABEL TO INCLUDE "ROHS" COMPLIANT, AMP P/N, 'MADE IN (COUNTRY OF ORIGIN)', AND DATE CODE.
- 14. HIGH TORQUE MOTOR DESIGN

HT17-221

REVISIONS

ECO NO.	REV	DESCRIPTION	DATE	APPROVED
6947	A	PRELIMINARY RELEASE	4/11/14	D.MACLEOD
7048	B	ERROR CORRECTION	8/11/14	D.MACLEOD
-	-	-	-	-
-	-	-	-	-
-	-	-	-	-
-	-	-	-	-
-	-	-	-	-
-	-	-	-	-
-	-	-	-	-
-	-	-	-	-
-	-	-	-	-
-	-	-	-	-

LABEL DETAIL

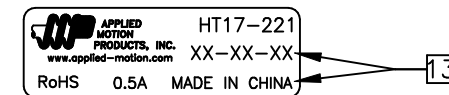

PHASE DETAIL

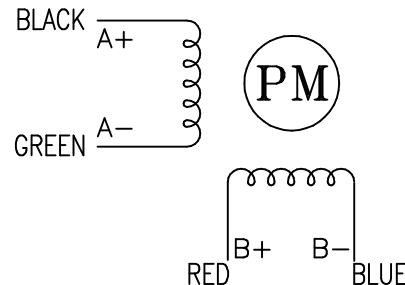

FULL STEP SWITCHING SEQUENCE
BI-POLAR, FACING MOUNTING END

STEP	A+	A-	B+	B-
0	+	-	+	-
1	-	+	+	-
2	-	+	-	+
3	+	-	-	+
4	+	-	+	-

CONTRACT NO. -		APPLIED MOTION PRODUCTS, INC.					
APPROVALS		DATE		STEP MOTOR OUTLINE			
DRAWN K.KESLER		8/11/14					
CHECKED -		-					
APPROVED -		-					
APPROVED -		-		B	COMPUTER DATA BASE DRAWING	DWG NO. HT17-221	REV B
SCALE: NONE		SHEET 1 OF 2					

2X #2-56 UNC
TAP THRU EQ.SP.
ON A $\phi 32.5$ B.C.

10

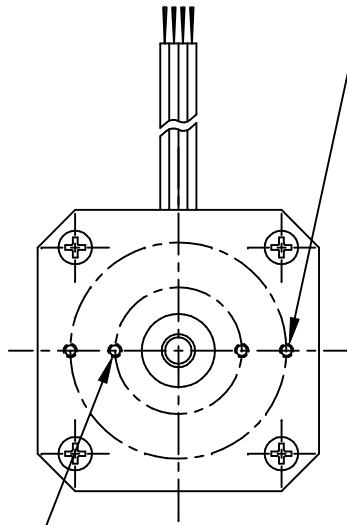

2X #2-56 UNC
TAP THRU EQ.SP.
ON A $\phi 19.05$ B.C.

10

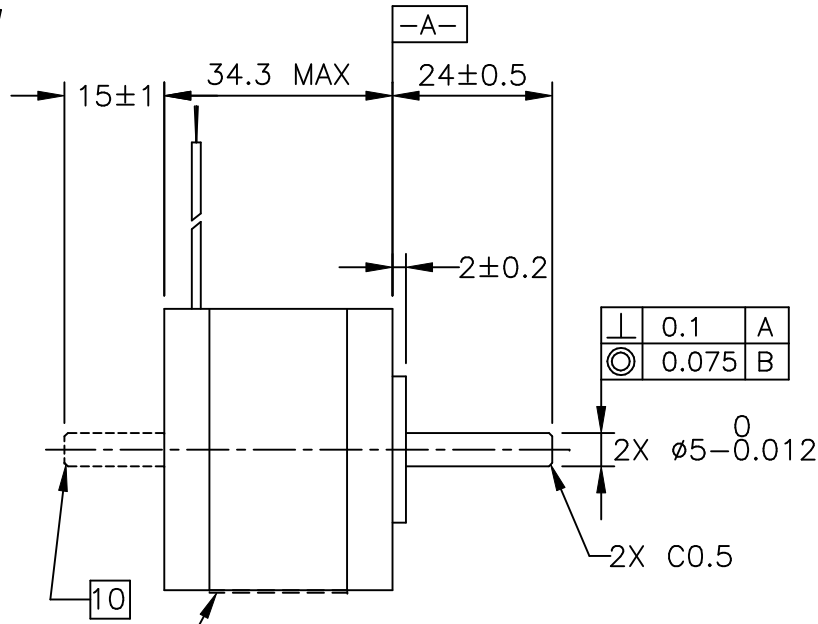

\perp	0.1	A
\odot	0.075	B

10

LABEL 13

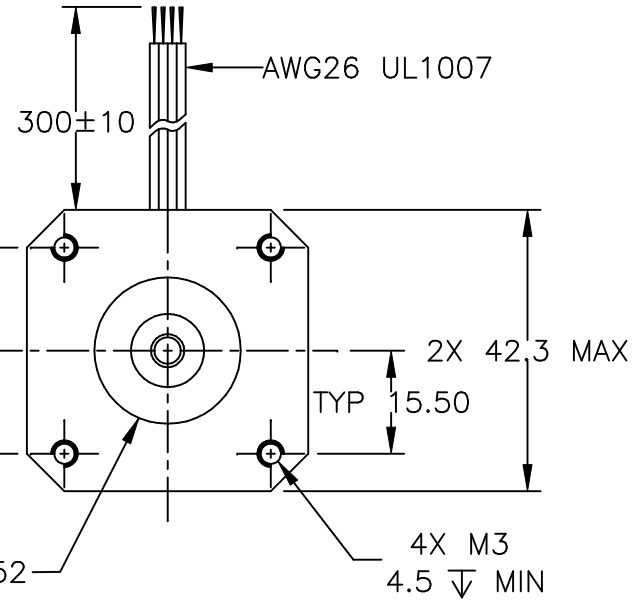

AWG26 UL1007

-B-

TOLERANCES *ALL DIMENSIONS IN MM DECIMALS: MM X.XX = ± 0.13 X.X = ± 0.25 ANGLES: MACH. = $\pm 0.5^\circ$ CHAM. = $\pm 5^\circ$	THIRD ANGLE PROJECTION 			
	APPROVALS DRAWN K.KESLER CHECKED - APPROVED -		DATE 8/11/14 - -	
	COMPUTER DATA BASE DRAWING		SCALE: NONE	
	STEP MOTOR OUTLINE		REV B	

DWG NO. HT17-221

SHEET 2 OF 2