

PRELIMINARY IN P/N DIR

CAUTION: STATIC SENSITIVE DEVICE
FOLLOW PROPER E.S.D. HANDLING PROCEDURES
WHEN WORKING WITH THIS PART.

CHARACTER DETAIL

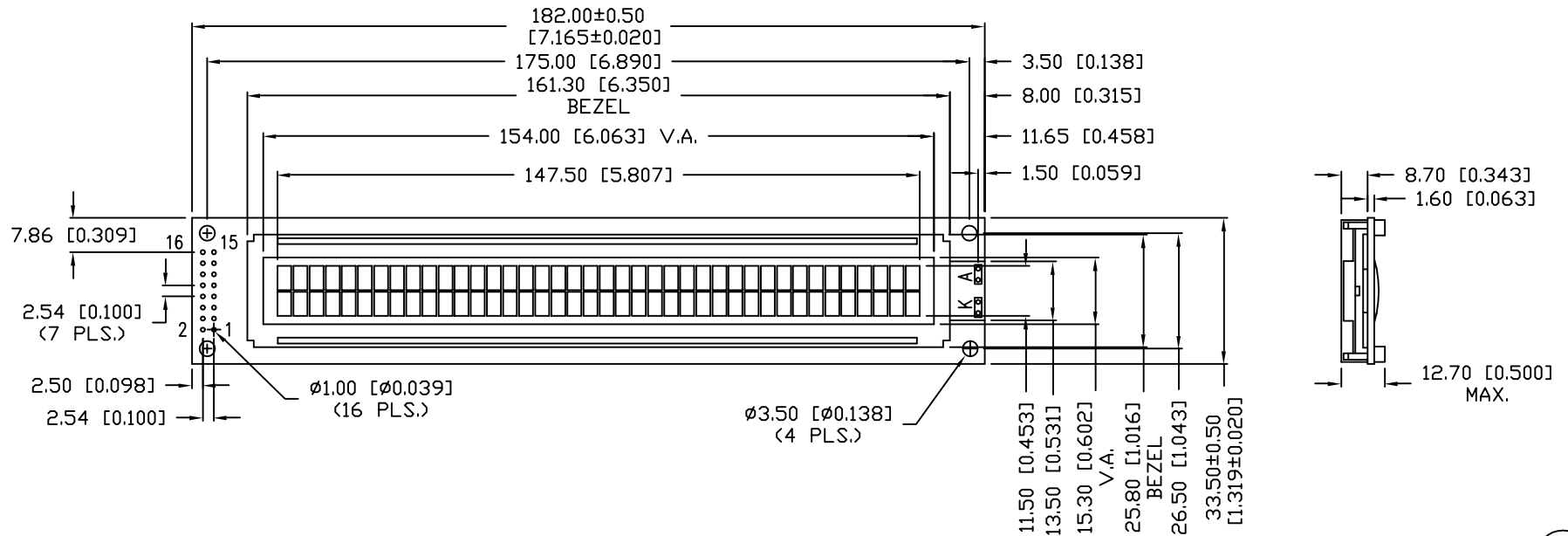
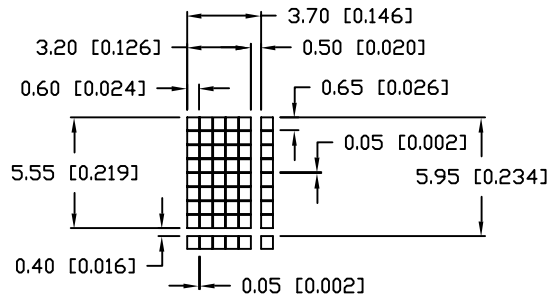

UNCONTROLLED DOCUMENT

*UNLESS OTHERWISE SPECIFIED TOLERANCES PER DECIMAL PRECISION ARE: X=±1 (±0.039), X.X=±0.5 (±0.020), X.XX=±0.25 (±0.010), X.XXX=±0.127 (±0.005). LEAD SIZE=±0.05 (±0.002), LEAD LENGTH=±0.75 (±0.030). MIN= +DECIMAL PRECISION -0.00 MAX= +0.00 -DECIMAL PRECISION

REV.	PART NUMBER LCM-H04002DWN-1G	<p>CONFIDENTIAL INFORMATION</p> <p>THE INFORMATION CONTAINED IN THIS DOCUMENT IS THE PROPERTY OF LUMEX INC. EXCEPT AS SPECIFICALLY AUTHORIZED IN WRITING BY LUMEX INC., THE HOLDER OF THIS DOCUMENT SHALL KEEP ALL INFORMATION CONTAINED HEREIN CONFIDENTIAL AND SHALL PROTECT SAME IN WHOLE OR IN PART FROM DISCLOSURE AND DISSEMINATION TO ALL THIRD PARTIES.</p>		<p>290 E. HELEN ROAD PALATINE, IL 60067-6976 PHONE: +1.847.359.2790 US WEB: www.lumex.com TW WEB: www.lumex.com.tw</p>		
<p>5 x 8 DOT MATRIX 40 x 2 LCD CHARACTER MODULE, 5.55mm CHARACTER HEIGHT, 1/16 DUTY, 1/5 BIAS, FSTN BLACK, NEGATIVE IMAGE, 525nm GREEN LED BACKLIGHT, 12:00 VIEW.</p>		<p>RELIABILITY NOTE</p> <p>OUR MANY YEARS OF EXPERIENCE DATA ACCUMULATION INDICATE THAT SOLDER HEAT IS A MAJOR CAUSE OF EARLY AND FUTURE FAILURE. PLEASE PAY ATTENTION TO YOUR SOLDERING PROCESS.</p>	<p>DRAWN BY: JN</p>	<p>CHECKED BY:</p>	<p>APPROVED BY:</p>	<p>DATE: 05.22.08 PAGE: 1 OF 2 SCALE: N/A</p>

PIN CONFIGURATION			
PIN NO.	SYMBOL	LEVEL	FUNCTION
1	V _{SS}	-	POWER SUPPLY GND (0V)
2	V _{DD}	-	
3	V _O	-	
4	RS	H/L	REGISTER SELECT SIGNAL H: DATA INPUT L: INSTRUCTION INPUT
5	R/W	H/L	H: DATA READ (MODULE-->MPU) L: DATA WRITE (MODULE<--MPU)
6	E	H,H->L	ENABLE
7~14	DB0~DB7	H/L	DATA BUS--SOFTWARE SELECTABLE 4 OR 8 BIT MODE.
15	A	-	ANODE LED BACKLIGHT
16	K	-	CATHODE LED BACKLIGHT

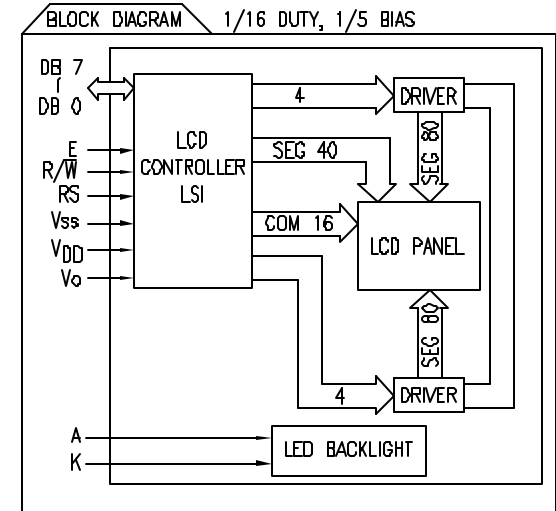
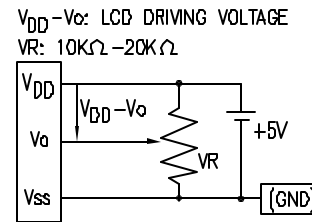

ELECTRICAL CHARACTERISTICS V_{DD}=4.7V to 5.3V, T_A=25°C

ITEM	SYMBOL	CONDITION	STANDARD VALUE			UNIT
			MIN.	TYP.	MAX.	
SUPPLY VOLTAGE FOR LOGIC	V _{DD} -V _{SS}	-	-	5.0	-	V
SUPPLY CURRENT FOR LOGIC	I _{DD}	V _{DD} =5V	-	2.0	3.0	mA
INPUT VOLTAGE	HIGH	V _{IH}	-	2.2	-	V _{DD}
	LOW	V _{IL}	-	0	-	0.6
OUTPUT VOLTAGE	HIGH	V _{OH}	-	2.4	-	V
	LOW	V _{OL}	-	-	-	0.4
LED BACKLIGHT	VOLTAGE	V _f	-	TBD	-	V
	CURRENT	I _f	-	TBD	-	mA
	POWER CONSUMPTION	PD	-	TBD	-	mW
	LUMINOUS	L	TBD	-	TBD	-
COLOR	-	-	-	525	-	nm

ABSOLUTE MAXIMUM RATINGS

ITEM	SYMBOL	TEST CONDITION	STANDARD VALUE		UNIT
			MIN	MAX	
SUPPLY VOLTAGE FOR LOGIC	V _{DD} -V _{SS}	T _a =25°C	4.7	5.3	V
SUPPLY VOLTAGE FOR LCD DRIVE	V _{DD} -V _O	-	4.2@50°C	4.8@0°C	V
INPUT VOLTAGE	V _I	T _a =25°C	V _{SS}	V _{DD}	V
OPERATING TEMPERATURE	T _{opr}	LCM-H	-20	70	°C
STORAGE TEMPERATURE	T _{stg}	LCM-H	-30	85	°C

*UNLESS OTHERWISE SPECIFIED TOLERANCES PER DECIMAL PRECISION ARE: X=±1 (±0.039), XX=±0.5 (±0.020), XXX=±0.25 (±0.010), XXXX=±0.127 (±0.005). LEAD SIZE=±0.05 (±0.002), LEAD LENGTH=±0.75 (±0.030), MIN.= +DECIMAL PRECISION -0.00, MAX.= +0.00 -DECIMAL PRECISION

REV. PART NUMBER
LCM-H04002DWN-1G

5 x 8 DOT MATRIX 40 x 2 LCD CHARACTER MODULE, 5.55mm CHARACTER HEIGHT, 1/16 DUTY, 1/5 BIAS, FSTN BLACK, NEGATIVE IMAGE, 525nm GREEN LED BACKLIGHT, 12:00 VIEW.

CONFIDENTIAL INFORMATION
THE INFORMATION CONTAINED IN THIS DOCUMENT IS THE PROPERTY OF LUMEX INC. EXCEPT AS SPECIFICALLY AUTHORIZED IN WRITING BY LUMEX INC., THE HOLDER OF THIS DOCUMENT SHALL KEEP ALL INFORMATION CONTAINED HEREIN CONFIDENTIAL AND SHALL PROTECT SAME IN WHOLE OR IN PART FROM DISCLOSURE AND DISSEMINATION TO ALL THIRD PARTIES.

RELIABILITY NOTE
OUR MANY YEARS OF EXPERIENCE DATA ACCUMULATION INDICATE THAT SOLDER HEAT IS A MAJOR CAUSE OF EARLY AND FUTURE FAILURE. PLEASE PAY ATTENTION TO YOUR SOLDERING PROCESS.



290 E. HELEN ROAD
PALATINE, IL 60067-6976
PHONE: +1.847.359.2790
US WEB: www.lumex.com
TW WEB: www.lumex.com.tw

DRAWN BY: JUN
CHECKED BY:
APPROVED BY:
DATE: 05.22.08
PAGE: 2 OF 2
SCALE: N/A