

LTM4618EV: 6A Step-Down Power µModule Regulator

DESCRIPTION

Demonstration circuit 1472 features the LTM[®]4618EV µModule[®] regulator, a complete high efficiency synchronous buck regulator. The DC1472 input range is from 4.5V to 26.5V and is capable of delivering up to 6A of output current. However, current derating may be necessary under certain V_{IN} , V_{OUT} , frequency and thermal conditions. The output voltage for the board is jumper programmable from 1.2V to 5V and can be set as low as 0.8V, the reference voltage of the LTM4618EV.

Layout is simple, requiring only a few bulk input and output capacitors externally. The TRACK/SS pin allows the user to program the output voltage ramp-up and ramp-down, as well as coincidentally or ratiometrically track an external voltage. The LTM4618EV may be enabled or disabled by the RUN pin. The MODE jumper (JP3) is available to select

from pulse-skipping or Burst Mode[®] operation for improved efficiency at light load. DC1472 has a default switching frequency of 500 kHz and is synchronizable to an external clock from 250 kHz up to 750 kHz. These features and the availability of the LTM4618EV in a compact 9mm × 15mm × 4.32mm LGA package make the demonstration circuit ideal for use in many high density point-of-load regulation applications. The LTM4618 data sheet must be read in conjunction with this demo manual for working on or modifying the demo circuit 1472A.

Design files for this circuit board are available at <http://www.linear.com/demo>

LT, LTC, LTM, µModule, Burst Mode, Linear Technology and the Linear logo are registered trademarks of Linear Technology Corporation. All other trademarks are the property of their respective owners.

BOARD PHOTO

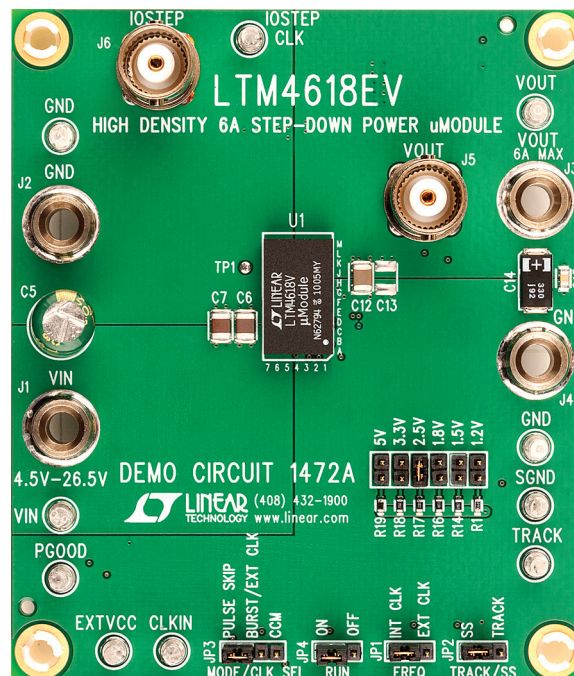

PERFORMANCE SUMMARY

PARAMETER	CONDITIONS/NOTES	VALUE
Input Voltage Range		4.5V to 26.5V
Jumper Selectable Output Voltage, V_{OUT}	$V_{IN} = 4.5V - 26.5V$, $I_{OUT} = 0A - 6A$	1.2V, 1.5V, 1.8V, 2.5V, 3.3V or 5V $\pm 2\%$
Maximum Continuous Output Current	Derating is Necessary for Certain Operating Conditions. See Data Sheet for Details	6A _{DC}
Default Operating Frequency	R3 = 10k Ω , R4 = 3.16k Ω	500kHz
External Clock Sync. Frequency Range		250kHz to 750kHz
Efficiency	$V_{IN} = 12V$, $V_{OUT} = 2.5V$, $I_{OUT} = 6A$	88.7% See Figure 2

QUICK START PROCEDURE

Demonstration circuit 1472 is easy to set up to evaluate the performance of the LTM4618EV. Please refer to Figure 1 for proper measurement equipment setup and follow the procedure below.

1. With power off, connect the input power supply, load and meters as shown in Figure 1. Preset the load to 0A and V_{IN} supply to be 0V. Place jumpers in the following positions for a typical 1.5V_{OUT} application:

JP6	JP3	JP4	JP2
V_{OUT} Select	MODE	RUN	TRACK/SS
1.5V	CCM	OFF	SS

2. Turn on the power at the input. Increase V_{IN} to 12V (Caution: Do not hot plug the input supply or apply more than the rated maximum voltage of 26.5V to the board or the part may be damaged).
3. Set the RUN pin jumper (JP4) to the on position. The output voltage should rise to 1.5V. The output voltage meter should read the selected output voltage $\pm 2\%$.
4. Vary the input voltage from 6V to 24V and adjust the load current from 0A to 6A. The output voltage meter should read the selected output voltage $\pm 2\%$. Set the input voltage to 12V and the load current to 6A.

5. Measure the output voltage ripple at J5 with a BNC cable and oscilloscope.
6. To set the output voltage to 5V, turn off the input supply power, apply the following changes listed below and repeat steps 2 to 5:

JP10	JP3	JP4	JP2
V_{OUT} Select	MODE	RUN	TRACK/SS
5V	CCM	OFF	SS

7. Set the load current to 0A. Set the RUN pin jumper (JP4) to the OFF position. Power off the input supply.
8. For load transient tests, apply an adjustable positive pulse signal between IOSTEP CLK and GND test points. The pulse amplitude sets the load step current amplitude. The pulse width should be short (<1ms) and pulse duty cycle should be low (<15%) to limit the thermal stress on the load transient circuit. The load step current can be monitored with a BNC connected to J6 (10mV/A).

QUICK START PROCEDURE

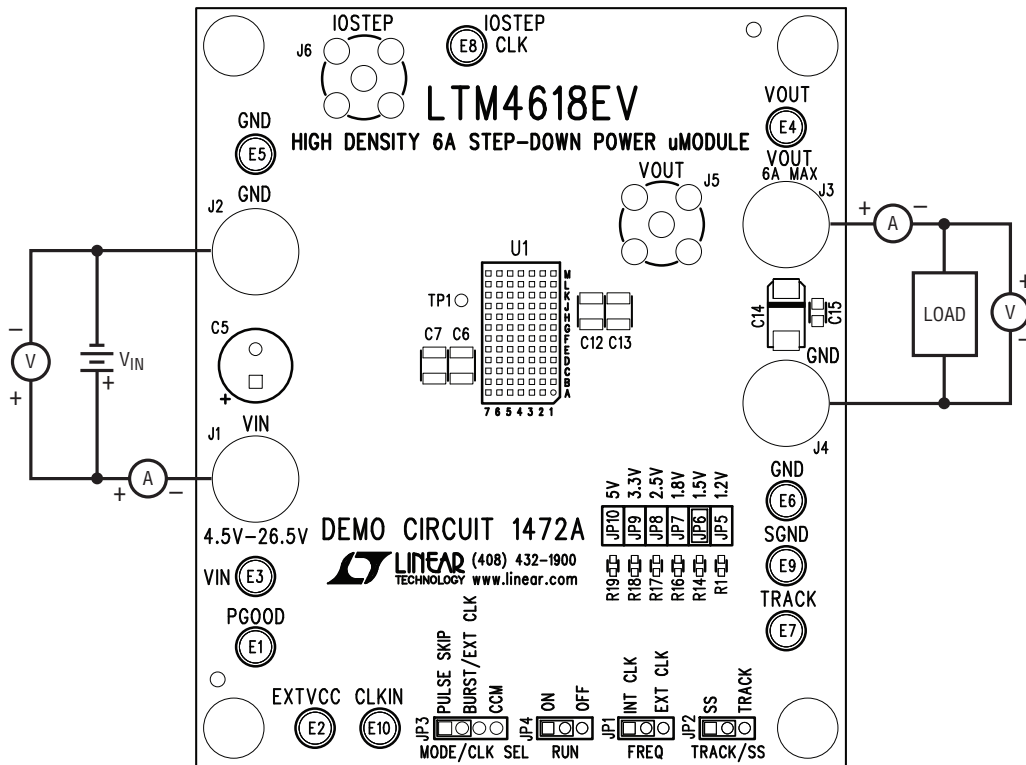

Figure 1. Proper Measurement Equipment Setup

QUICK START PROCEDURE

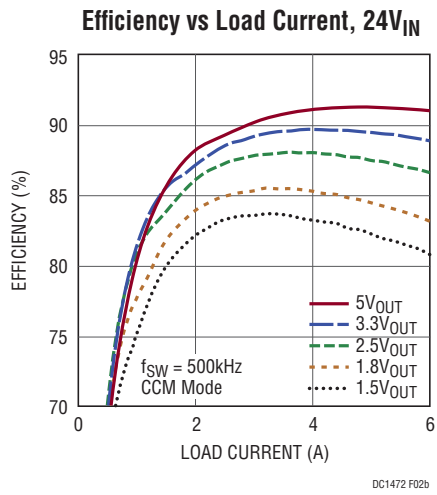
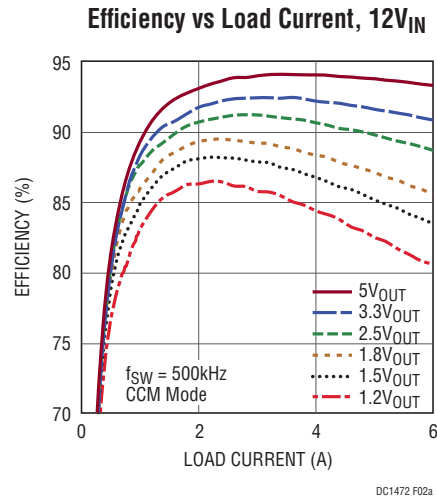
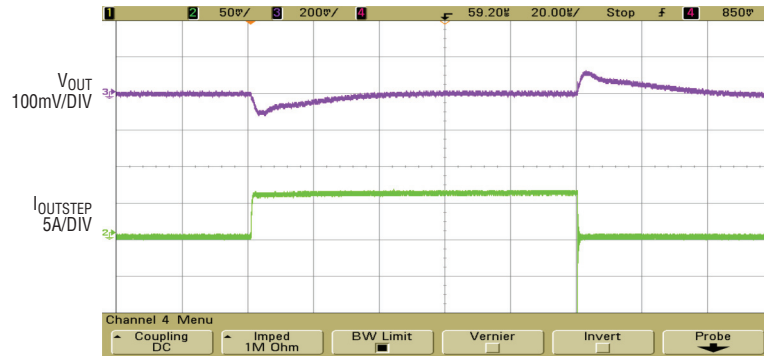

Figure 2. Measured Supply Efficiency at 12V_{IN} and 24V_{IN}

QUICK START PROCEDURE



V_{IN} (V)	V_{OUT} (V)	C_{OUT} BULK	C_{OUT} CERAMIC
12	1.5	330 μ F/6.3V POSCAP	1 \times 47 μ F 10V

Figure 3. Measured Load Transient Response (0A to 6A Load Step)

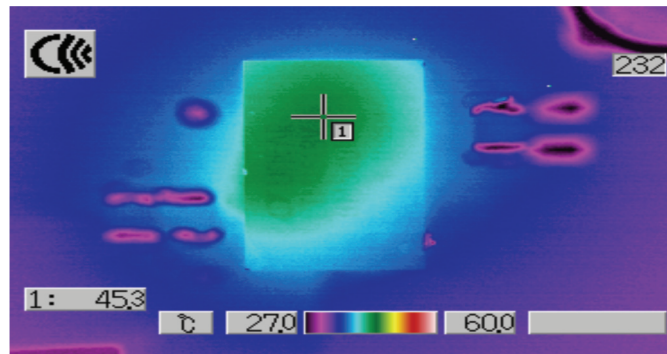

V_{IN} (V)	V_{OUT} (V)	I_{OUT} (A)	AIRFLOW	AMBIENT ($^{\circ}$ C)
12	1.5	6	Natural Convection	27

Figure 4. Measured Thermal Capture

DEMO MANUAL DC1472A

PARTS LIST

ITEM	QTY	REFERENCE	PART DESCRIPTION	MANUFACTURER/PART NUMBER
Required Circuit Components				
1	1	C5	CAP, 150µF 35V, ALUM	SANYO, 35ME150WXV+TS
2	2	C6, C7	CAP, X5R, 10µF 35V, 1210	TAIYO YUDEN, GMK325BJ106MN-T
3	1	C12	CAP, X5R, 47µF 10V, 1210	TDK, C3225X5R1A476M
4	1	C14	CAP, POSCAP, 330µF 6.3V, 7343	SANYO, 6TPC330MA
5	1	C15	CAP, X5R, 1µF 10V, 0805	AVX, 0805ZD105MAT2A
6	1	C20	CAP, X7R, 0.1µF 16V, 0603	AVX, 0603YC104KAT2A
7	1	R1	RES., 121k 1/16W 1%, 0603	VISHAY, CRCW0603121KFKEA
8	4	R3, R11	RES., 10k 1/16W 1%, 0603	VISHAY, CRCW060310K0FKEA
9	1	R4	RES., 3.16k 1/16W 1%, 0603	VISHAY, CRCW06033K16FKEA
10	1	R5	RES., 60.4k 1/16W 1%, 0603	VISHAY, CRCW060360K4FKEA
11	1	R14	RES., 69.8k 1/16W 1%, 0603	VISHAY, CRCW060369K8FKEA
12	1	R16	RES., 48.7k 1/16W 1%, 0603	VISHAY, CRCW060348K7FKEA
13	1	R17	RES., 28.7k 1/16W 1%, 0603	VISHAY, CRCW060328K7FKEA
14	1	R18	RES., 19.1k 1/16W 1%, 0603	VISHAY, CRCW060319K1FKEA
15	1	R19	RES., 11.5k 1/16W 1%, 0603	VISHAY, CRCW060311K5FKEA
16	1	U1	IC, LTM4618EV	LINEAR TECH., LTM4618EV LGA
Additional Demo Board Circuit Components				
1	0	C1-C4, C16, C19, C21-C24	CAP, 0603 Optional	
2	0	C8, C9, C10, C11, C13	CAP, 1210 Optional	
3	2	C17, C18	CAP, X5R, 1µF 10V, 0603	TAIYO YUDEN, LMK107BJ105MA-T
4	0	R6, R8, R10, R12	RES, 0603 Optional	
5	4	R7	RES., 10k 1/16W 1%, 0603	VISHAY, CRCW060310K0FKEA
6	1	R9	RES., 0.01Ω 5% 1W, 2512	IRC, LRC-LRF2512LF-01-R010-J
7	1	R15	RES., 10k 1/16W 1%, 0603	VISHAY, CRCW060310K0FKEA
8	1	R2	RES., 100k 1/16W 1%, 0603	VISHAY, CRCW0603100KFKEA
9	1	R13	RES., CHIP, 0, 1/16W, 0603	VISHAY, CRCW06030000Z0EA
10	1	D1	DIODE, ZENER 350MW 4.7V, SOT-23	DIODES INC., BZX84C4V7-7-F
11	1	Q1	XSTR, SUD50N03-10CP MOSFET	SILICONIX, SUD50N03-10CP
Hardware				
1	10	E1-E10	TP, TURRET, 0.094", PBF	MILL-MAX, 2501-2-00-80-00-00-07-0
2	3	JP1, JP2, JP4	JMP, 1X3, 0.079"	SAMTEC, TMM-103-02-L-S
3	1	JP3	JMP, 1X4, 0.079"	SAMTEC, TMM-104-02-L-S
4	6	JP5, JP6, JP7, JP8, JP9, JP10	JMP, 1X2, 0.079"	SAMTEC, TMM-102-02-L-S
5	4	J1, J2, J3, J4	JACK, BANANA	KEYSTONE, 575-4
6	2	J5, J6	CONN, BNC, 5 PINS	CONNEX, 112404
7	5	JP1-JP4, JP6	SHUNT, 0.079" CENTER	SAMTEC, 2SN-BK-G
8	4	4 Corners	STANDOFF, SNAP ON, 0.50"	KEYSTONE, 8833

SCHEMATIC DIAGRAM

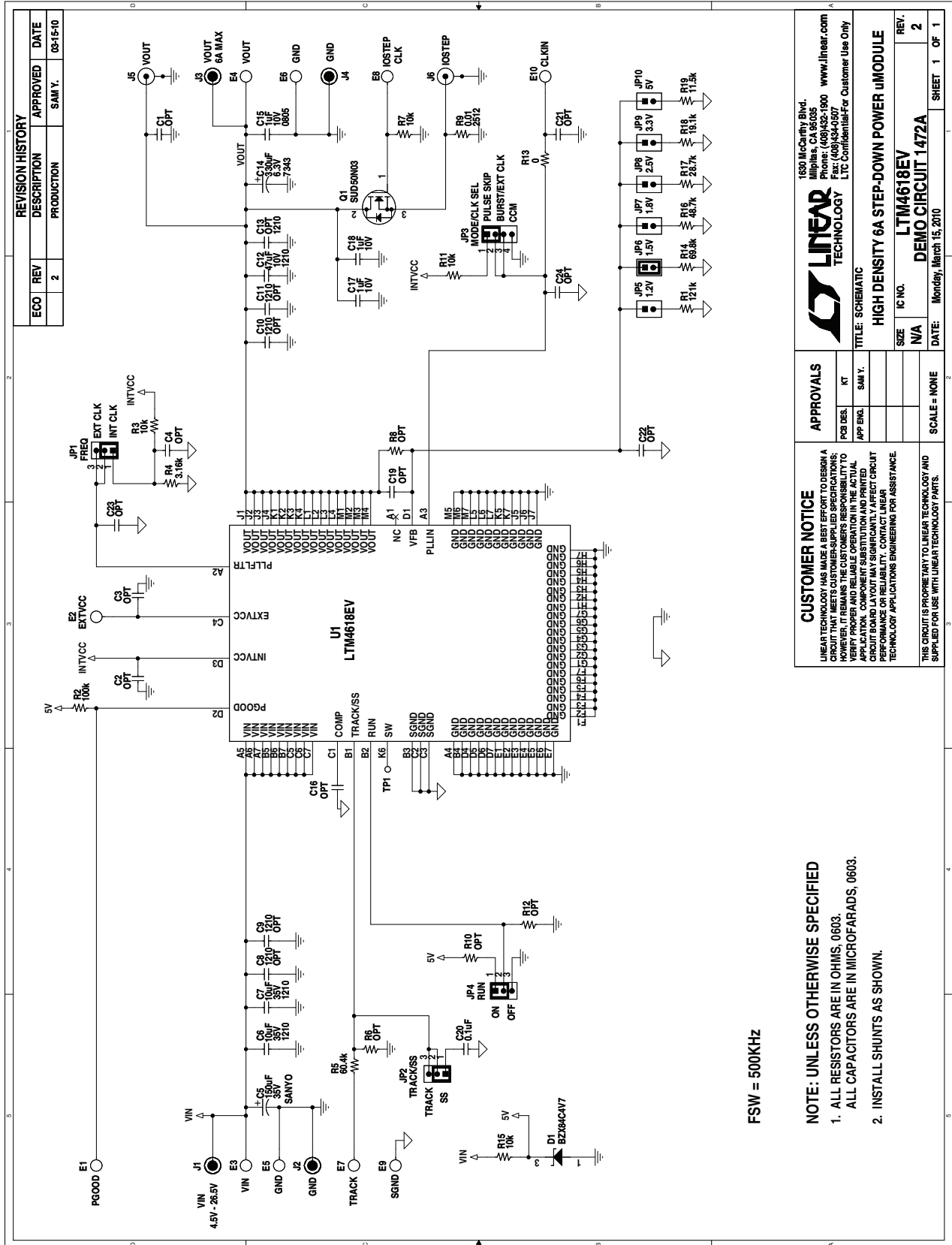

FSW = 500KHz

- NOTE: UNLESS OTHERWISE SPECIFIED**
1. ALL RESISTORS ARE IN OHMS, 0603.
 2. ALL CAPACITORS ARE IN MICROFARADS, 0603.
 3. INSTALL SHUNTS AS SHOWN.

REVISION HISTORY		
ECO	REV	DESCRIPTION
	2	PRODUCTION
		APPROVED DATE
		SAMI Y. 08-15-10

1650 McCarthy Blvd.
Folsom, CA 95635
Tel: 916.444.0000
Fax: 916.444.0077
www.linear.com

LINEAR TECHNOLOGY
LTC Confidential For Customer Use Only

CUSTOMER NOTICE
LINEAR TECHNOLOGY HAS MADE A BEST EFFORT TO DESIGN A CIRCUIT THAT MEETS CUSTOMER-SUPPLIED SPECIFICATIONS. HOWEVER, IT REMAINS THE CUSTOMER'S RESPONSIBILITY TO VERIFY PROPER AND RELIABLE OPERATION IN THE ACTUAL APPLICATION. COMPONENT SUBSTITUTION AND PRINTED CIRCUIT BOARD (PCB) LAYOUT MAY AFFECT CIRCUIT PERFORMANCE. CONTACT LINEAR TECHNOLOGY FOR ASSISTANCE.

APPROVALS

PCB DES.	KT
APP ENGR.	SAMI Y.

TITLE: SCHEMATIC

HIGH DENSITY 6A STEP-DOWN POWER uMODULE

SIZE: N/A
IC NO.: LTM4618EV
REV.: 2

SCALE = NONE

DATE: Monday, March 15, 2010

SHEET 1 OF 1



Information furnished by Linear Technology Corporation is believed to be accurate and reliable. However, no responsibility is assumed for its use. Linear Technology Corporation makes no representation that the interconnection of its circuits as described herein will not infringe on existing patent rights.

DEMO MANUAL DC1472A

DEMONSTRATION BOARD IMPORTANT NOTICE

Linear Technology Corporation (LTC) provides the enclosed product(s) under the following **AS IS** conditions:

This demonstration board (DEMO BOARD) kit being sold or provided by Linear Technology is intended for use for **ENGINEERING DEVELOPMENT OR EVALUATION PURPOSES ONLY** and is not provided by LTC for commercial use. As such, the DEMO BOARD herein may not be complete in terms of required design-, marketing-, and/or manufacturing-related protective considerations, including but not limited to product safety measures typically found in finished commercial goods. As a prototype, this product does not fall within the scope of the European Union directive on electromagnetic compatibility and therefore may or may not meet the technical requirements of the directive, or other regulations.

If this evaluation kit does not meet the specifications recited in the DEMO BOARD manual the kit may be returned within 30 days from the date of delivery for a full refund. **THE FOREGOING WARRANTY IS THE EXCLUSIVE WARRANTY MADE BY THE SELLER TO BUYER AND IS IN LIEU OF ALL OTHER WARRANTIES, EXPRESSED, IMPLIED, OR STATUTORY, INCLUDING ANY WARRANTY OF MERCHANTABILITY OR FITNESS FOR ANY PARTICULAR PURPOSE. EXCEPT TO THE EXTENT OF THIS INDEMNITY, NEITHER PARTY SHALL BE LIABLE TO THE OTHER FOR ANY INDIRECT, SPECIAL, INCIDENTAL, OR CONSEQUENTIAL DAMAGES.**

The user assumes all responsibility and liability for proper and safe handling of the goods. Further, the user releases LTC from all claims arising from the handling or use of the goods. Due to the open construction of the product, it is the user's responsibility to take any and all appropriate precautions with regard to electrostatic discharge. Also be aware that the products herein may not be regulatory compliant or agency certified (FCC, UL, CE, etc.).

No License is granted under any patent right or other intellectual property whatsoever. **LTC assumes no liability for applications assistance, customer product design, software performance, or infringement of patents or any other intellectual property rights of any kind.**

LTC currently services a variety of customers for products around the world, and therefore this transaction **is not exclusive**.

Please read the DEMO BOARD manual prior to handling the product. Persons handling this product must have electronics training and observe good laboratory practice standards. **Common sense is encouraged.**

This notice contains important safety information about temperatures and voltages. For further safety concerns, please contact a LTC application engineer.

Mailing Address:

Linear Technology
1630 McCarthy Blvd.
Milpitas, CA 95035

Copyright © 2004, Linear Technology Corporation

dc1472af



Linear Technology Corporation
1630 McCarthy Blvd., Milpitas, CA 95035-7417
(408) 432-1900 • FAX: (408) 434-0507 • www.linear.com

LT 1010 • PRINTED IN USA
**LINEAR**
TECHNOLOGY
© LINEAR TECHNOLOGY CORPORATION 2010