

# PRODUCT DATA DRAWING

REVISION HISTORY			
REV	DESCRIPTION	DATE	APPROVED
-	REL. DCN 35469	10/25/07	STW

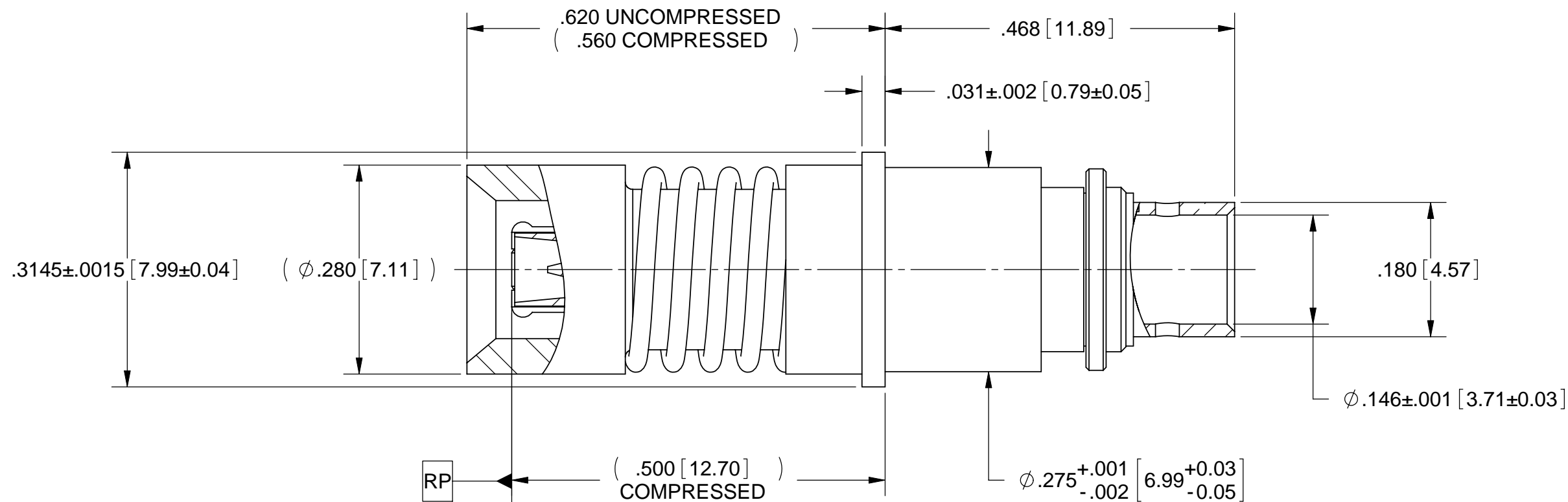

- MATERIAL:**
- BODY & SLEEVE:** STAINLESS STEEL PER AMS-5640, ALLOY UNS S30300, TYPE 1
- FERRULE:** BRASS PER ASTM B16 ALLOY UNS No. 36000
- CONTACT LOCK RING:** BERYLLIUM COPPER PER ASTM B196, ALLOY No. UNS C17300, TD04
- INSULATOR:** PTFE PER ASTM D1710, TYPE I, GRADE 1, CLASS B
- GASKET:** SILICONE RUBBER PER A-A-59588, CLASS 2B, GRADE 50/60
- SPRING:** STAINLESS STEEL PER ASTM A313, TYPE 631.
- FINISH:**
- BODY, SLEEVE & SPRING:** PASSIVATED PER AMS-2700, TYPE 2.
- CONTACT & FERRULE:** GOLD PER ASTM B488, TYPE II, CODE C, CLASS 1.27; OVER NICKEL PER AMS-QQ-N-290, CLASS 1, .00005" MIN.
- LOCK RING:** NICKEL PER AMS-QQ-N-290.

- PERFORMANCE:**
- IMPEDANCE:** 50 OHMS
- FREQ. RANGE:** DC TO 18.0 GHz
- VSWR:** 1.25:1 MATED PAIR DC TO 18.0 GHz
- INSERTION LOSS:** .06 X SQRT(F(F IN GHz))
- DWV:** 1000 VRMS
- OPERATING TEMP.:** -55°C TO +125°C

## SIZE 8 SOCKET CONTACT

<b>MATERIAL:</b> SEE NOTES	<b>DIMENSIONS ARE IN INCHES TOLERANCES:</b> FRACTIONAL: ±1/64 ANGULAR: X° ±1'0" X'X' ±15'	<b>UNLESS OTHERWISE SPECIFIED</b> 1) ALL DIMENSIONS ARE IN INCHES (MILLIMETERS) 2) ALL DIMENSIONS ARE AFTER PLATING. 3) BREAK CORNERS & EDGES .005 R. MAX. 4) CHAM. 1ST & LAST THREADS. 5) SURFACE ROUGHNESS $\sqrt{63}$ MIL-STD-10. 6) DIA.'S ON COMMON CENTERS TO BE CONCENTRIC WITHIN .005 T.I.R. 7) REMOVE ALL BURRS	<b>SV Microwave, Inc.</b> 2400 Centrepark West Drive, Suite 100 West Palm Beach, FL 33409
<b>FINISH:</b> SEE NOTES	DECIMAL: .X ±.030 .XX ±.010 .XXX ±.005	INTERPRET DIMENSIONS AND TOLERANCES PER ASME Y14.5M - 1994	<b>TITLE:</b> 18 GHZ BMZ MALE TO RG-402 FOR M38999 SIZE 8 CAVITY
<b>SURFACE AREA:</b> N/A	<b>PROPRIETARY</b> THE INFORMATION CONTAINED IN THIS DRAWING IS THE SOLE PROPERTY OF SV MICROWAVE, INC. ANY REPRODUCTION IN PART OR AS A WHOLE WITHOUT THE WRITTEN PERMISSION OF SV MICROWAVE, INC IS PROHIBITED.	<b>THIRD ANGLE PROJECTION</b> 	<b>SIZE:</b> B <b>CAGE CODE:</b> 95077 <b>DWG. NO.:</b> SF9811-6001
		<b>DRAWN:</b> JMC 10/25/07 <b>CHECKED:</b> STW 10/25/07 <b>APPROVED:</b> STW 10/25/07	<b>SCALE:</b> 6:1 <b>SHEET 1 OF 1</b>