

Customer Information Sheet

DRAWING No.: M80-889XXXX

SHEET 2 OF 2

IF IN DOUBT - ASK

©

NOT TO SCALE

THIRD ANGLE PROJECTION

ALL DIMENSIONS IN mm

SPECIFICATION:

MATERIAL:
 MOULDING = GLASS-FILLED PBT UL94V-0, BLACK
 CLIP = BERYLLIUM COPPER
 SHELL = COPPER ALLOY

FINISH (ALL OVER NICKEL):

CONTACTS:
 01 = 0.75µ GOLD CLIP, 4µ 100% TIN OVER NICKEL SHELL
 05 = 0.30µ GOLD CLIP, 0.28µ GOLD SHELL

ELECTRICAL:
 CURRENT RATING AT 25°C = 3.0A MAX
 CURRENT RATING AT 85°C = 2.2A MAX
 WORKING VOLTAGE = 120V AC/DC
 VOLTAGE PROOF = 360V AC/DC

CONTACT RESISTANCE:
 INITIAL = 20mΩ MAX
 AFTER CONDITIONING = 25mΩ MAX
INSULATION RESISTANCE:
 INITIAL = 1000MΩ MIN
 AFTER CONDITIONING = 100MΩ MIN

MECHANICAL:
 DURABILITY = 500 OPERATIONS
 INSERTION FORCE = 2.8N MAX, 1.0N MIN
 WITHDRAWAL FORCE = 1.8N MAX, 0.2N MIN

ENVIRONMENTAL:
 TEMPERATURE RANGE = -55°C TO +125°C

PACKING:
 BAG (CONTACTS AND MOULDINGS UN-ASSEMBLED)
 FOR COMPLETE SPECIFICATION, SEE COMPONENT SPECIFICATION C005XX (LATEST ISSUE)

NOTES:

- RECOMMENDED WIRE TYPE = BS3G210 TYPE A, PTFE INSULATED, 22 AWG. MAX INSULATION DIAMETER = Ø1.10mm, STRIP WIRE BY 2.00mm.
- FOR EXTRA CONTACTS, USE PART NUMBER M80-0110005 FOR M80-889XX05 AND M80-0110001 FOR M80-889XX01.
- RECOMMENDED HAND CRIMP TOOL = M22520/2-01 WITH POSITIONER T5747. REFER TO TOOLING INSTRUCTION SHEET IS-01 FOR COMPLETE CRIMPING INSTRUCTIONS.
- CONTACT INSERTION AND EXTRACTION TOOL = Z80-280. REFER TO TOOLING INSTRUCTION SHEET IS-25 FOR ASSEMBLY INSTRUCTIONS.

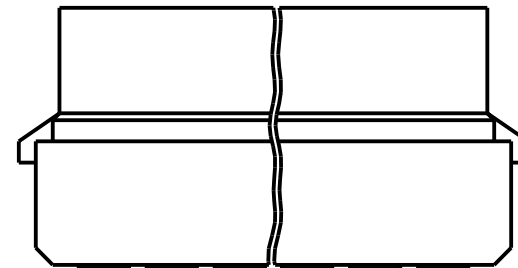
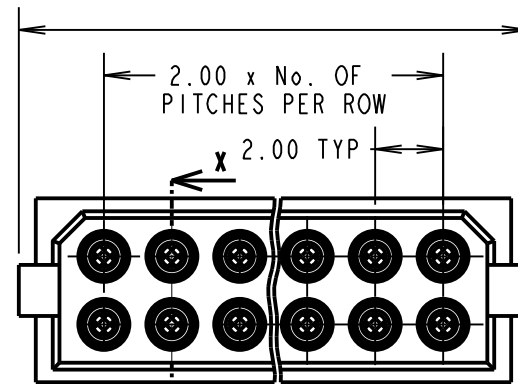
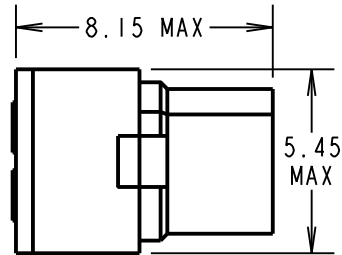

2.00 x No. OF WAYS PER ROW
 + 3.15 MAX

SECTION X-X

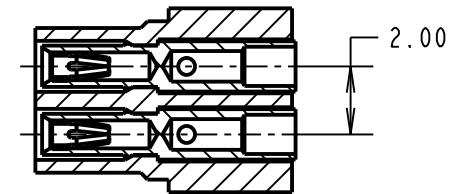

COMMERCIAL ORDER CODE:

M80-889XXXX

TOTAL No. OF WAYS
 04, 06, 08, 10, 12, 14, 16,
 18, 20, 26, 34

FINISH:
 01 - GOLD CLIP, 100% TIN SHELL
 05 - GOLD CLIP, GOLD SHELL

BRITISH STANDARD ORDER CODE: TO BS9525 F0033

B5740-2XX-F-D-X

TOTAL No. OF WAYS
 04, 06, 08, 10, 12, 14, 16,
 18, 20, 26, 34

FINISH:
 0 - GOLD CLIP, TIN SHELL
 2 - GOLD CLIP, GOLD SHELL

SB	11	22.07.11	11376
NAME	ISS.	DATE	C/NOTE
APPROVED:		S.BENNETT	
CHECKED:		M.G.PLESTED	
DRAWN:		W. J. BOURNE	
CUSTOMER REF.:			
ASSEMBLY DRG.:			

HARWIN

HARWIN USA TEL: 603 893 5376 FAX: 603 893 5396 mis@harwin.com	HARWIN Europe (UK) TEL: 023 9231 4545 FAX: 023 9231 4590 mis@harwin.co.uk	HARWIN Asia TEL: +65 6 779 4909 FAX: +65 6 779 3868 mis@harwin.com.sg
--	--	--

THIS DRAWING AND ANY INFORMATION OR DESCRIPTIVE MATTER SET OUT HEREON ARE CONFIDENTIAL AND COPYRIGHT PROPERTY OF THE HARWIN GROUP AND MUST NOT BE DISCLOSED, LOANED, COPIED OR USED FOR MANUFACTURING, TENDERING OR FOR ANY OTHER PURPOSE WITHOUT THEIR WRITTEN PERMISSION.

TOLERANCES
 X. = ±1mm
 X.X = ±0.25mm
 X.XX = ±0.10mm
 X.XXX = ±0.01mm
 ANGLES = ±5°
 UNLESS STATED

MATERIAL:
 SEE ABOVE
FINISH: SEE ABOVE
S/AREA: mm²

TITLE: DATAMATE 2mm PITCH CRIMP DIL SOCKET ASSY LARGE BORE (22 AWG)
DRAWING NUMBER:
M80-889XXXX
 SHT 2 OF 2