

THIS DOCUMENT IS THE PROPERTY OF KEYSTONE ELECTRONICS CORP. AND SHALL NOT BE REPRODUCED, DISTRIBUTED OR USED AS A BASIS FOR MANUFACTURE WITHOUT PRIOR WRITTEN PERMISSION FROM KEYSTONE ELECTRONICS CORP.

MOUNTING PAD LAYOUT

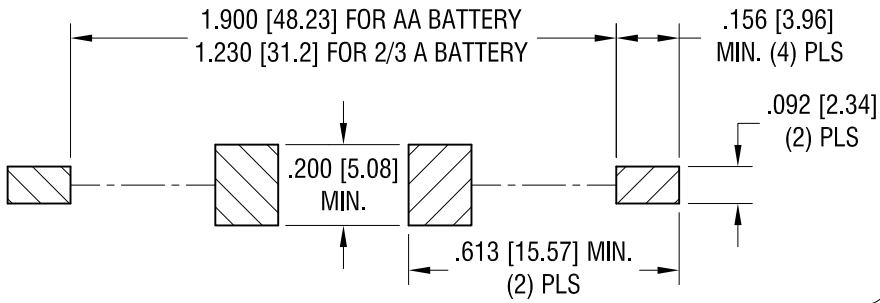

ACTUAL SIZE

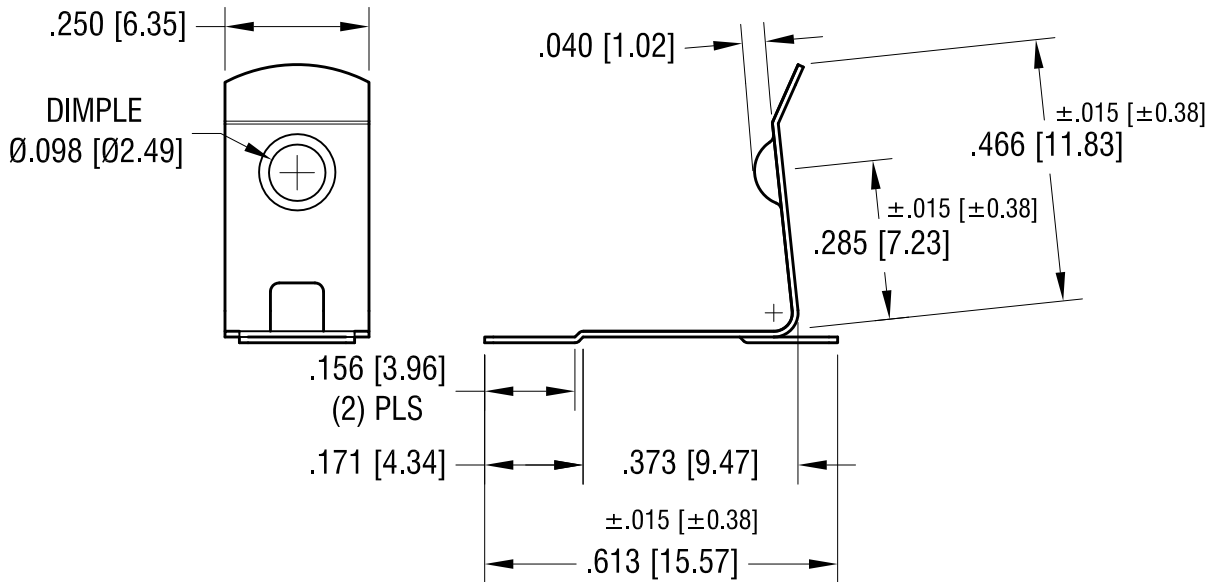
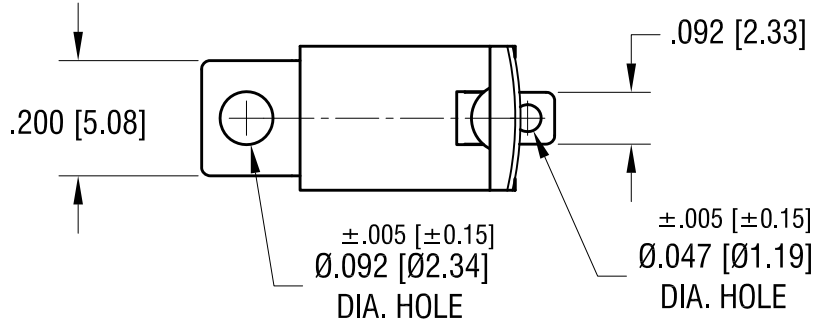
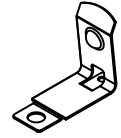

NOTE:

- HEAT TREAT TO SPRING TEMPER.

KEYSTONE ELECTRONICS CORP.

www.keyelco.com • NEW HYDE PARK, NY 11040 • Tel (516) 328-7500

PART NAME

'AA' SMT BATTERY CLIP

MATERIAL

.010 [0.25] TH'K ANNEALED SPRING STEEL

FINISH

TIN-NICKEL PLATE

DRN BY

NT

DATE

8.27.09

APP'D

LN

SCALE

3X

TOLERANCES

INCH [MM]

DECIMAL

± .010 [± 0.25]

ANGULAR

± 1°

UNLESS OTHERWISE SPECIFIED

CODE

C

DWG NO.

57

DATE	DESCRIPTION	REV.
4.06.17	CHANGE AS PER ECR17-019	C
1.25.11	CHANGE AS PER ECN 11-008	B
8.10.09	CHANGE AS PER ECN 09-111	A