

THD 92 x 92 x 38 MM SERIES

■ DIMENSIONS DRAWING

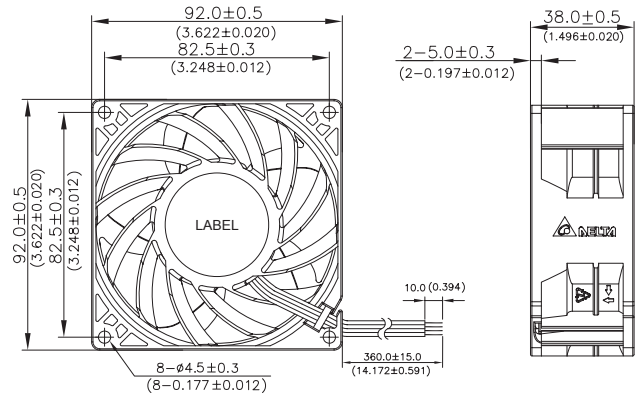

UNIT: MM(INCH)

- * Bearing Type
Ball Bearings
- * Material
Impeller & Frame : Plastic (UL 94V-0)
- * Lead Wires :
UL 1430 AWG #26 OR Equivalent
Red Wire Positive(+)
Black Wire Negative(-)
Yellow Wire Speed Control(PWM)
Blue Wire (F00)
- * Weight : 215g (7.58 OZ)

■ P & Q CURVE (AT RATED VOLTAGE)

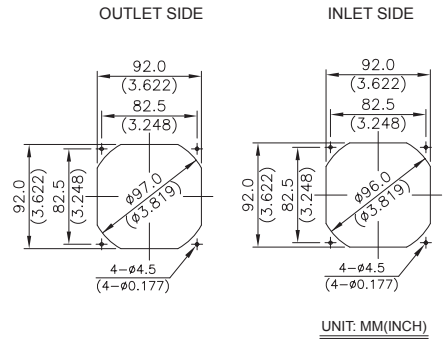
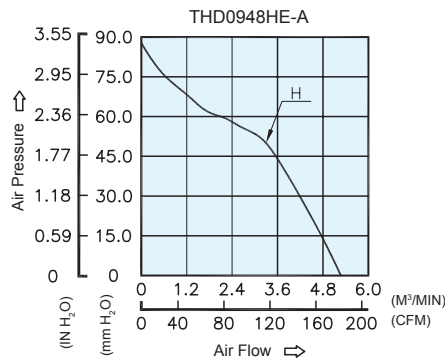

UNIT: MM(INCH)



MODEL			Rated Voltage	Operating Voltage Range	Rated Current	Rated Input Power	Speed	Maximum Air Flow		Maximum Air Pressure		Noise
PART NO.	REV.	FUNCTION	VDC	AC	Amp	Watt	R.P.M.	m ³ /min	CFM	mmH ₂ O	IN H ₂ O	dB-A
THD0948HE	-A	PWM/F00	48	36.0 to 75.0	1.10	52.80	13500	5.167	182.41	87.24	3.435	71.0

- * Function type is optional.
- * The max. air flow and the speed are measured in free air ; max. air pressure is measured at zero air flow.
- * Noise is measured in anechoic chamber in free air, one meter from intake side.
- * All readings are typical values at rated voltage.
- * Specifications are subject to change without notice.