

256-Kbit (32 K × 8) Byte-wide F-RAM Memory

Features

- 256-Kbit ferroelectric random access memory (F-RAM) logically organized as 32 K × 8
 - High-endurance 100 trillion (10¹⁴) read/writes
 - 151-year data retention (see the [Data Retention and Endurance](#) table)
 - NoDelay™ writes
 - Advanced high-reliability ferroelectric process
- SRAM and EEPROM compatible
 - Industry-standard 32 K × 8 SRAM and EEPROM pinout
 - 70-ns access time, 130-ns cycle time
- Superior to battery-backed SRAM modules
 - No battery concerns
 - Monolithic reliability
 - True surface mount solution, no rework steps
 - Superior for moisture, shock, and vibration
 - Resistant to negative voltage undershoots
- Low power consumption
 - Active current 15 mA (max)
 - Standby current 25 μA (typ)
- Voltage operation: V_{DD} = 4.5 V to 5.5 V

- Industrial temperature: -40 °C to +85 °C
- 28-pin small outline integrated circuit (SOIC) package
- Restriction of hazardous substances (RoHS) compliant

Functional Overview

The FM1808B is a 32 K × 8 nonvolatile memory that reads and writes similar to a standard SRAM. A ferroelectric random access memory or F-RAM is nonvolatile, which means that data is retained after power is removed. It provides data retention for over 151 years while eliminating the reliability concerns, functional disadvantages, and system design complexities of battery-backed SRAM (BBSRAM). Fast write timing and high write endurance make the F-RAM superior to other types of memory.

The FM1808B operation is similar to that of other RAM devices and therefore, it can be used as a drop-in replacement for a standard SRAM in a system. Minimum read and write cycle times are equal. The F-RAM memory is nonvolatile due to its unique ferroelectric memory process. These features make the FM1808B ideal for nonvolatile memory applications requiring frequent or rapid writes.

The device is available in a 28-pin SOIC surface mount package. Device specifications are guaranteed over the industrial temperature range -40 °C to +85 °C.

For a complete list of related documentation, click [here](#).

Logic Block Diagram

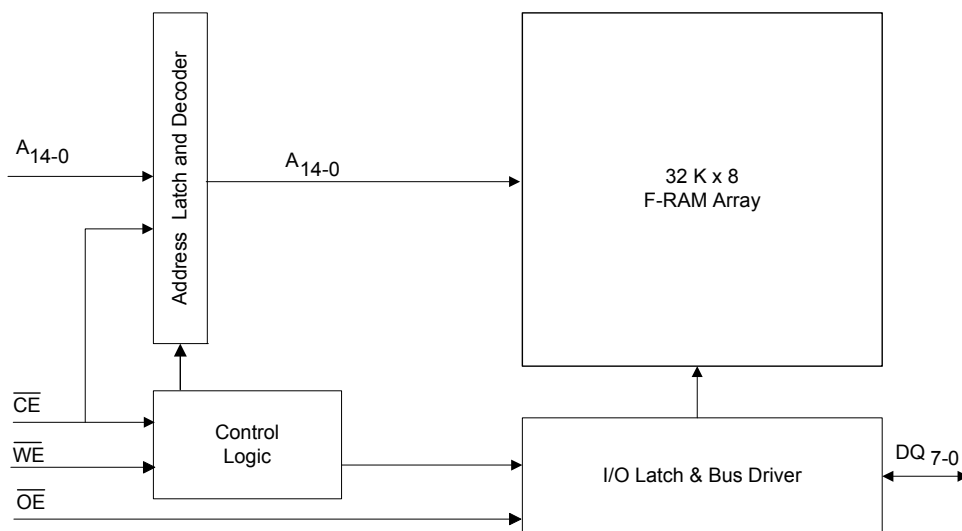

Contents

Pinout	3	AC Switching Characteristics	9
Pin Definitions	3	SRAM Read Cycle	9
Device Operation	4	SRAM Write Cycle	10
Memory Architecture	4	Power Cycle Timing	12
Memory Operation	4	Functional Truth Table	13
Read Operation	4	Ordering Information	14
Write Operation	4	Ordering Code Definitions	14
Pre-charge Operation	4	Package Diagram	15
Endurance	4	Acronyms	16
F-RAM Design Considerations	5	Document Conventions	16
Maximum Ratings	7	Units of Measure	16
Operating Range	7	Document History Page	17
DC Electrical Characteristics	7	Sales, Solutions, and Legal Information	18
Data Retention and Endurance	7	Worldwide Sales and Design Support	18
Capacitance	8	Products	18
Thermal Resistance	8	PSoC® Solutions	18
AC Test Conditions	8	Cypress Developer Community	18
		Technical Support	18

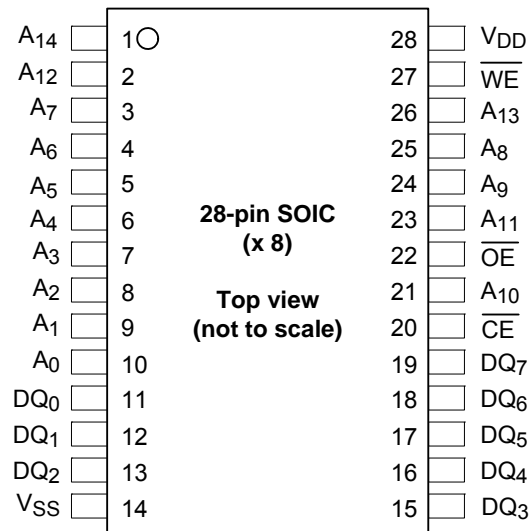
Pinout
Figure 1. 28-pin SOIC pinout

Pin Definitions

Pin Name	I/O Type	Description
A ₁₄ –A ₀	Input	Address inputs: The 15 address lines select one of 32,768 bytes in the F-RAM array.
DQ ₇ –DQ ₀	Input/Output	Data I/O Lines: 8-bit bidirectional data bus for accessing the F-RAM array.
\overline{WE}	Input	Write Enable: A write cycle begins when \overline{WE} is asserted. Asserting \overline{WE} LOW causes the FM1808B to write the contents of the data bus to the address location latched by the falling edge of \overline{CE} .
\overline{CE}	Input	Chip Enable: The device is selected when \overline{CE} is LOW. Asserting \overline{CE} LOW causes the address to be latched internally. Address changes that occur after \overline{CE} goes LOW will be ignored until the next falling edge occurs.
\overline{OE}	Input	Output Enable: When \overline{OE} is LOW, the FM1808B drives the data bus when the valid read data is available. Deasserting \overline{OE} HIGH tristates the DQ pins.
V _{SS}	Ground	Ground for the device. Must be connected to the ground of the system.
V _{DD}	Power supply	Power supply input to the device.
NC	No connect	No connect. This pin is not connected to the die.

Device Operation

The FM1808B is a byte-wide F-RAM memory logically organized as $32,768 \times 8$ and accessed using an industry-standard parallel interface. All data written to the part is immediately nonvolatile with no delay. Functional operation of the F-RAM memory is the same as SRAM type devices, except the FM1808B requires a falling edge of \overline{CE} to start each memory cycle. See the [Functional Truth Table on page 13](#) for a complete description of read and write modes.

Memory Architecture

Users access 32,768 memory locations, each with 8 data bits through a parallel interface. The complete 15-bit address specifies each of the 32,768 bytes uniquely. The F-RAM array is organized as 4092 rows of 8-bytes each. This row segmentation has no effect on operation, however the user can group data into blocks by its endurance characteristics as explained in the [Endurance](#) section.

The cycle time is the same for read and write memory operations. This simplifies memory controller logic and timing circuits. Likewise the access time is the same for read and write memory operations. When \overline{CE} is deasserted HIGH, a pre-charge operation begins, and is required of every memory cycle. Thus unlike SRAM, the access and cycle times are not equal. Writes occur immediately at the end of the access with no delay. Unlike an EEPROM, it is not necessary to poll the device for a ready condition since writes occur at bus speed.

It is the user's responsibility to ensure that V_{DD} remains within datasheet tolerances to prevent incorrect operation. Also proper voltage level and timing relationships between V_{DD} and \overline{CE} must be maintained during power-up and power-down events. See ["Power Cycle Timing"](#) on page 12.

Memory Operation

The FM1808B is designed to operate in a manner similar to other byte-wide memory products. For users familiar with BBSRAM, the performance is comparable but the byte-wide interface operates in a slightly different manner as described below. For users familiar with EEPROM, the differences result from the higher write performance of F-RAM technology including NoDelay writes and much higher write endurance.

Read Operation

A read operation begins on the falling edge of \overline{CE} . At this time, the address bits are latched and a memory cycle is initiated. Once started, a full memory cycle must be completed internally even if \overline{CE} goes inactive. Data becomes available on the bus after the access time is met.

After the address has been latched, the address value may be changed upon satisfying the hold time parameter. Unlike an SRAM, changing address values will have no effect on the memory operation after the address is latched.

The FM1808B will drive the data bus when \overline{OE} is asserted LOW and the memory access time is met. If \overline{OE} is asserted after the memory access time is met, the data bus will be driven with valid

data. If \overline{OE} is asserted before completing the memory access, the data bus will not be driven until valid data is available. This feature minimizes supply current in the system by eliminating transients caused by invalid data being driven to the bus. When \overline{OE} is deasserted HIGH, the data bus will remain in a HI-Z state.

Write Operation

In the FM1808B, writes occur in the same interval as reads. The FM1808B supports both \overline{CE} and \overline{WE} controlled write cycles. In both cases, the address is latched on the falling edge of \overline{CE} .

In a \overline{CE} -controlled write, the \overline{WE} signal is asserted before beginning the memory cycle. That is, \overline{WE} is LOW when the device is activated with the chip enable. In this case, the device begins the memory cycle as a write. The FM1808B will not drive the data bus regardless of the state of \overline{OE} .

In a \overline{WE} -controlled write, the memory cycle begins on the falling edge of \overline{CE} . The \overline{WE} signal falls after the falling edge of \overline{CE} . Therefore, the memory cycle begins as a read. The data bus will be driven according to the state of \overline{OE} until \overline{WE} falls. The \overline{CE} and \overline{WE} controlled write timing cases are shown in the [page 12](#).

Write access to the array begins asynchronously after the memory cycle is initiated. The write access terminates on the rising edge of \overline{WE} or \overline{CE} , whichever comes first. A valid write operation requires the user to meet the access time specification before deasserting \overline{WE} or \overline{CE} . The data setup time indicates the interval during which data cannot change before the end of the write access.

Unlike other nonvolatile memory technologies, there is no write delay with F-RAM. Because the read and write access times of the underlying memory are the same, the user experiences no delay through the bus. The entire memory operation occurs in a single bus cycle. Therefore, any operation including read or write can occur immediately following a write. Data polling, a technique used with EEPROMs to determine if a write is complete, is unnecessary.

Pre-charge Operation

The pre-charge operation is an internal condition in which the memory state is prepared for a new access. All memory cycles consist of a memory access and a pre-charge. Pre-charge is user-initiated by driving the \overline{CE} signal HIGH. It must remain HIGH for at least the minimum pre-charge time, t_{PC} .

The user determines the beginning of this operation since a pre-charge will not begin until \overline{CE} rises. However, the device has a maximum \overline{CE} LOW time specification that must be satisfied.

Endurance

Internally, a F-RAM operates with a read and restore mechanism. Therefore, each read and write cycle involves a change of state. The memory architecture is based on an array of rows and columns. Each read or write access causes an endurance cycle for an entire row. In the FM1808B, a row is 64 bits wide. Every 8-byte boundary marks the beginning of a new row. Endurance can be optimized by ensuring frequently accessed data is located in different rows. Regardless, F-RAM

offers substantially higher write endurance than other nonvolatile memories. The rated endurance limit of 10^{14} cycles will allow 150,000 accesses per second to the same row for over 20 years.

F-RAM Design Considerations

When designing with F-RAM for the first time, users of SRAM will recognize a few minor differences. First, byte-wide F-RAM memories latch each address on the falling edge of chip enable. This allows the address bus to change after starting the memory access. Since every access latches the memory address on the falling edge of \overline{CE} , users cannot ground it as they might with SRAM.

Users who are modifying existing designs to use F-RAM should examine the memory controller for timing compatibility of address and control pins. Each memory access must be qualified with a LOW transition of \overline{CE} . In many cases, this is the only change required. An example of the signal relationships is shown in Figure 2 below. Also shown is a common SRAM signal relationship that will not work for the FM1808B.

The reason for \overline{CE} to strobe for each address is twofold: it latches the new address and creates the necessary pre-charge period while \overline{CE} is HIGH.

Figure 2. Chip Enable and Memory Address Relationships

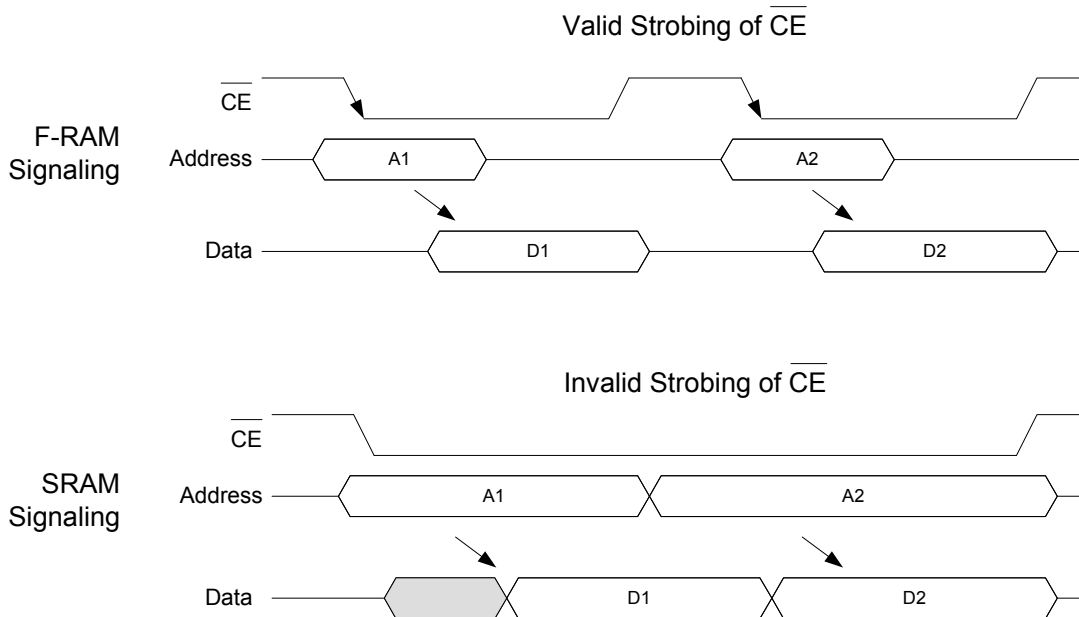

A second design consideration relates to the level of V_{DD} during operation. Battery-backed SRAMs are forced to monitor V_{DD} in order to switch to battery backup. They typically block user access below a certain V_{DD} level in order to prevent loading the battery with current demand from an active SRAM. The user can be abruptly cut off from access to the nonvolatile memory in a power down situation with no warning or indication.

F-RAM memories do not need this system overhead. The memory will not block access at any V_{DD} level that complies with the specified operating range. The user should take measures to prevent the processor from accessing memory when V_{DD} is out-of-tolerance. The common design practice of holding a processor in reset during power-down may be sufficient. It is recommended that chip enable is pulled HIGH and allowed to track V_{DD} during power-up and power-down cycles. It is the user's responsibility to ensure that chip enable is HIGH to prevent accesses below V_{DD} min. (4.5 V).

Figure 3 shows a pull-up resistor on \overline{CE} , which will keep the pin HIGH during power cycles, assuming the MCU / MPU pin

tristates during the reset condition. The pull-up resistor value should be chosen to ensure the CE pin tracks V_{DD} to a high enough value, so that the current drawn when \overline{CE} is LOW is not an issue.

Figure 3. Use of Pull-up Resistor on \overline{CE}

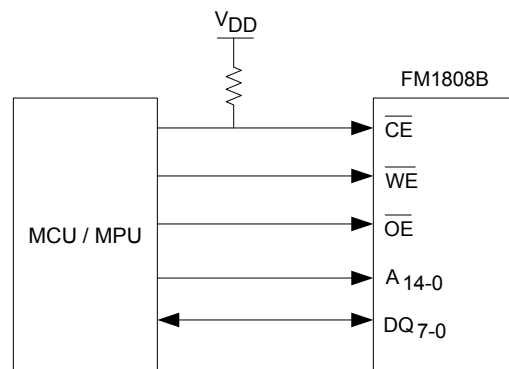

Note that if \overline{CE} is tied to ground, the user must be sure \overline{WE} is not LOW at power-up or power-down events. If the chip is enabled and \overline{WE} is LOW during power cycles, data will be corrupted. Figure 4 shows a pull-up resistor on \overline{WE} , which will keep the pin HIGH during power cycles, assuming the MCU / MPU pin tristates during the reset condition. The pull-up resistor value should be chosen to ensure the \overline{WE} pin tracks V_{DD} to a high enough value, so that the current drawn when \overline{WE} is LOW is not an issue.

Figure 4. Use of Pull-up Resistor on \overline{WE}

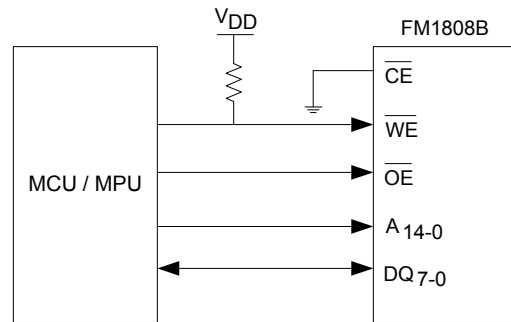

Maximum Ratings

Exceeding maximum ratings may shorten the useful life of the device. These user guidelines are not tested.

Storage temperature	-55 °C to +125 °C
Maximum junction temperature	95 °C
Supply voltage on V _{DD} relative to V _{SS}	-1.0 V to + 7.0 V
Voltage applied to outputs in High Z state	-0.5 V to V _{DD} + 0.5 V
Input voltage	-1.0 V to + 7.0 V and V _{IN} < V _{DD} + 1.0 V
Transient voltage (< 20 ns) on any pin to ground potential	-2.0 V to V _{CC} + 2.0 V
Package power dissipation capability (T _A = 25 °C)	1.0 W

Surface mount Pb soldering temperature (3 seconds)	+260 °C
DC output current (1 output at a time, 1s duration)	15 mA
Static discharge voltage	
Human Body Model (AEC-Q100-002 Rev. E)	4 kV
Charged Device Model (AEC-Q100-011 Rev. B)	1.25 kV
Machine Model (AEC-Q100-003 Rev. E)	300 V
Latch-up current	> 140 mA

Operating Range

Range	Ambient Temperature (T _A)	V _{DD}
Industrial	-40 °C to +85 °C	4.5 V to 5.5 V

DC Electrical Characteristics

Over the [Operating Range](#)

Parameter	Description	Test Conditions	Min	Typ ^[1]	Max	Unit
V _{DD}	Power supply voltage		4.5	5.0	5.5	V
I _{DD}	V _{DD} supply current	V _{DD} = 5.5 V, \overline{CE} cycling at min. cycle time. All inputs toggling at CMOS levels (0.2 V or V _{DD} - 0.2 V), all DQ pins unloaded.	-	-	15	mA
I _{SB1}	Standby current (TTL)	V _{DD} = 5.5 V, \overline{CE} at V _{IH} . All other pins are static and at TTL levels (0.2 V or V _{DD} - 0.2 V)	-	-	1.8	mA
I _{SB2}	Standby current (CMOS)	V _{DD} = 5.5 V, \overline{CE} at V _{IH} . All other pins are static and at CMOS levels (0.2 V or V _{DD} - 0.2 V)	-	25	50	μA
I _{LI}	Input leakage current	V _{IN} between V _{DD} and V _{SS}	-	-	±1	μA
I _{LO}	Output leakage current	V _{OUT} between V _{DD} and V _{SS}	-	-	±1	μA
V _{IH}	Input HIGH voltage		2.0	-	V _{DD} + 0.3	V
V _{IL}	Input LOW voltage		-0.3	-	0.8	V
V _{OH1}	Output HIGH voltage	I _{OH} = -2.0 mA	2.4	-	-	V
V _{OH2}	Output HIGH voltage	I _{OH} = -100 μA	V _{DD} - 0.2	-	-	V
V _{OL1}	Output LOW voltage	I _{OL} = 4.2 mA	-	-	0.4	V
V _{OL2}	Output LOW voltage	I _{OL} = 150 μA	-	-	0.2	V

Data Retention and Endurance

Parameter	Description	Test condition	Min	Max	Unit
T _{DR}	Data retention	At +85 °C	10	-	Years
		At +75 °C	38	-	
		At +65 °C	151	-	
NV _C	Endurance	Over operating temperature	10 ¹⁴	-	Cycles

Note

1. Typical values are at 25 °C, V_{DD} = V_{DD} (typ). Not 100% tested.

Capacitance

Parameter	Description	Test Conditions	Max	Unit
$C_{I/O}$	Input/Output capacitance (DQ)	$T_A = 25\text{ }^\circ\text{C}$, $f = 1\text{ MHz}$, $V_{DD} = V_{DD}(\text{Typ})$	8	pF
C_{IN}	Input capacitance		6	pF

Thermal Resistance

Parameter	Description	Test Conditions	28-pin SOIC	Unit
Θ_{JA}	Thermal resistance (junction to ambient)	Test conditions follow standard test methods and procedures for measuring thermal impedance, in accordance with EIA/JESD51.	58	$^\circ\text{C/W}$
Θ_{JC}	Thermal resistance (junction to case)		26	$^\circ\text{C/W}$

AC Test Conditions

- Input pulse levels0 V to 3V
- Input rise and fall times (10%–90%) $\leq 10\text{ ns}$
- Input and output timing reference levels 1.5
- Output load capacitance 100 pF

Figure 5. AC Test Loads

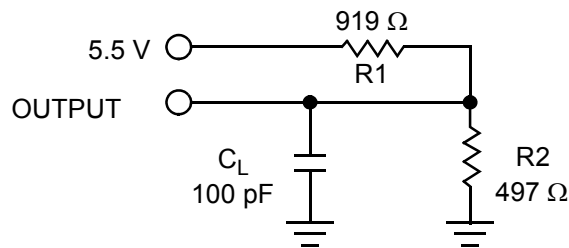

AC Switching Characteristics

Over the [Operating Range](#)

Parameters ^[2]		Description	Min	Max	Unit
Cypress Parameter	Alt Parameter				
SRAM Read Cycle					
t _{CE}	t _{ACE}	Chip enable access time	–	70	ns
t _{CA}	–	Chip enable active time	70	–	ns
t _{RC}	–	Read cycle time	130	–	ns
t _{PC}	–	Pre-charge time	60	–	ns
t _{AS}	t _{SA}	Address setup time	0	–	ns
t _{AH}	t _{HA}	Address hold time	15	–	ns
t _{OE}	t _{DOE}	Output enable access time	–	12	ns
t _{HZ} ^[3, 4]	t _{HZCE}	Chip Enable to output HI-Z	–	15	ns
t _{OHZ} ^[3, 4]	t _{HZOE}	Output enable HIGH to output HI-Z	–	15	ns

Notes

- Test conditions assume a signal transition time of 10 ns or less, timing reference levels of $0.5 \times V_{DD}$, input pulse levels of 0 to 3 V, output loading of the specified I_{OL}/I_{OH} and load capacitance shown in [AC Test Conditions on page 8](#).
- t_{HZ} and t_{OHZ} are specified with a load capacitance of 5 pF. Transition is measured when the outputs enter a high impedance state.
- This parameter is characterized but not 100% tested.

AC Switching Characteristics (continued)

 Over the [Operating Range](#)

Parameters ^[2]		Description	Min	Max	Unit
Cypress Parameter	Alt Parameter				
SRAM Write Cycle					
t_{WC}	t_{WC}	Write cycle time	130	–	ns
t_{CA}	–	Chip enable active time	70	–	ns
t_{CW}	t_{SCE}	Chip enable to write enable HIGH	70	–	ns
t_{PC}	–	Pre-charge time	60	–	ns
t_{WP}	t_{PWE}	Write enable pulse width	40	–	ns
t_{AS}	t_{SA}	Address setup time	0	–	ns
t_{AH}	t_{HA}	Address hold time	15	–	ns
t_{DS}	t_{SD}	Data input setup time	30	–	ns
t_{DH}	t_{HD}	Data input hold time	0	–	ns
$t_{WZ}^{[5, 6]}$	t_{HZWE}	Write enable LOW to output HI-Z	–	15	ns
$t_{WX}^{[6]}$	–	Write enable HIGH to output driven	10	–	ns
$t_{HZ}^{[5]}$	–	Chip enable to output HI-Z	–	15	ns
$t_{WS}^{[7]}$	–	Write enable to \overline{CE} LOW setup time	0	–	ns
$t_{WH}^{[7]}$	–	Write enable to \overline{CE} HIGH hold time	0	–	ns

Notes

5. t_{WZ} and t_{HZ} is specified with a load capacitance of 5 pF. Transition is measured when the outputs enter a high impedance state.
6. This parameter is characterized but not 100% tested.
7. The relationship between \overline{CE} and \overline{WE} determines if a \overline{CE} or \overline{WE} controlled write occurs. There is no timing specification associated with this relationship.

Figure 6. Read Cycle Timing 1



Figure 7. Read Cycle Timing 2 (\overline{CE} Controlled)



Figure 8. Write Cycle Timing 1 (\overline{WE} Controlled)

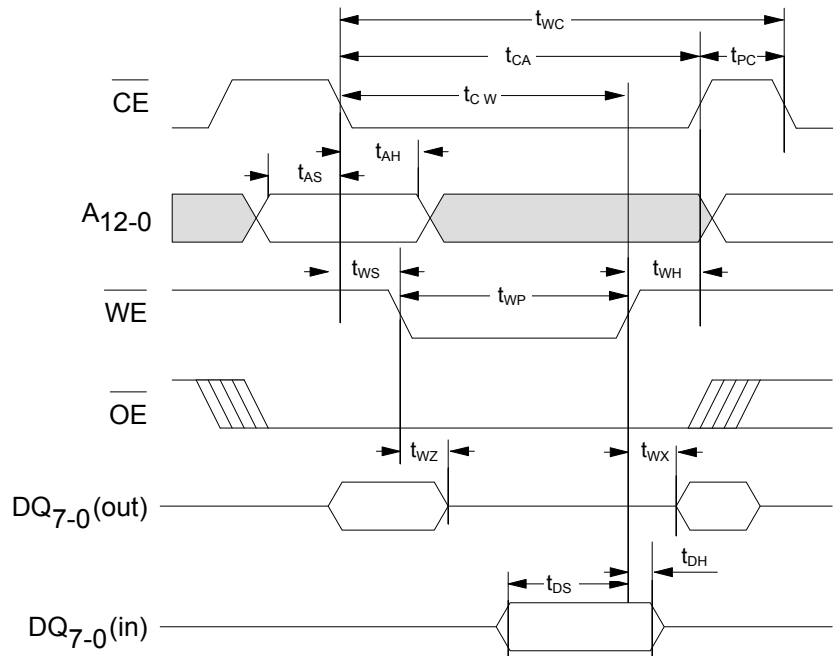

Power Cycle Timing

Over the [Operating Range](#)

Parameter	Description	Min	Max	Unit
t_{PU}	Power-up (after V_{DD} min. is reached) to first access time	10	–	ms
t_{PD}	Last write (\overline{WE} HIGH) to power down time	0	–	μ s
$t_{VR}^{[8]}$	V_{DD} power-up ramp rate	30	–	μ s/V
$t_{VF}^{[8]}$	V_{DD} power-down ramp rate	30	–	μ s/V

Figure 9. Power Cycle Timing

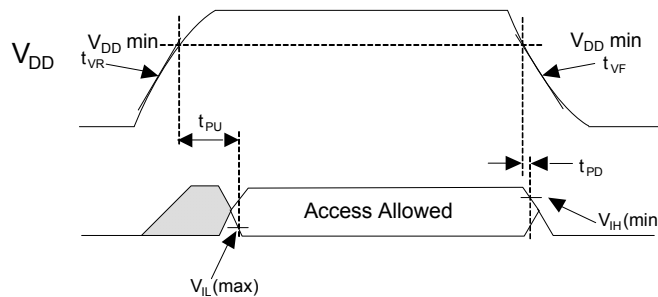

Note

8. Slope measured at any point on the V_{DD} waveform.

Functional Truth Table

\overline{CE}	\overline{WE}	Operation ^[9, 10]
H	X	Standby/Pre-charge
↓	X	Latch Address (and begin write if \overline{WE} = LOW)
L	H	Read
L	↓	Write

Notes

9. H = Logic HIGH, L = Logic LOW, V = Valid Data, X = Don't Care, ↓ = toggle LOW, ↑ = toggle HIGH.
 10. The \overline{OE} pin controls only the DQ output buffers.

Ordering Information

Ordering Code	Package Diagram	Package Type	Operating Range
FM1808B-SG	51-85026	28-pin SOIC	Industrial
FM1808B-SGTR	51-85026	28-pin SOIC	

All the above parts are Pb-free.

Ordering Code Definitions

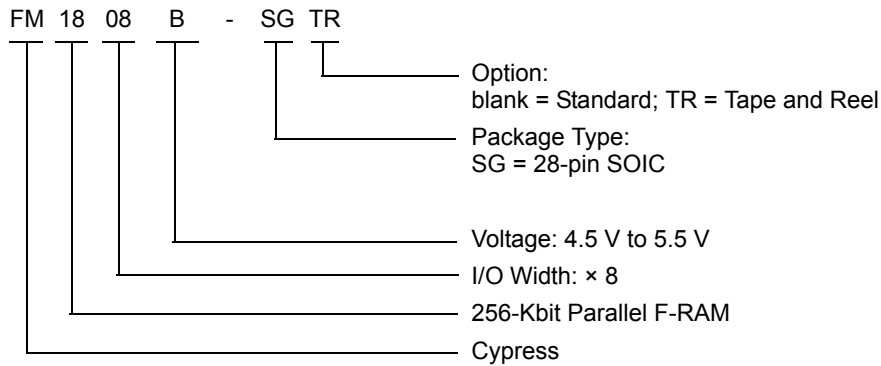

Package Diagram

Figure 10. 28-pin SOIC Package Outline, 51-85026

28 Lead (300 Mil) SOIC – S21

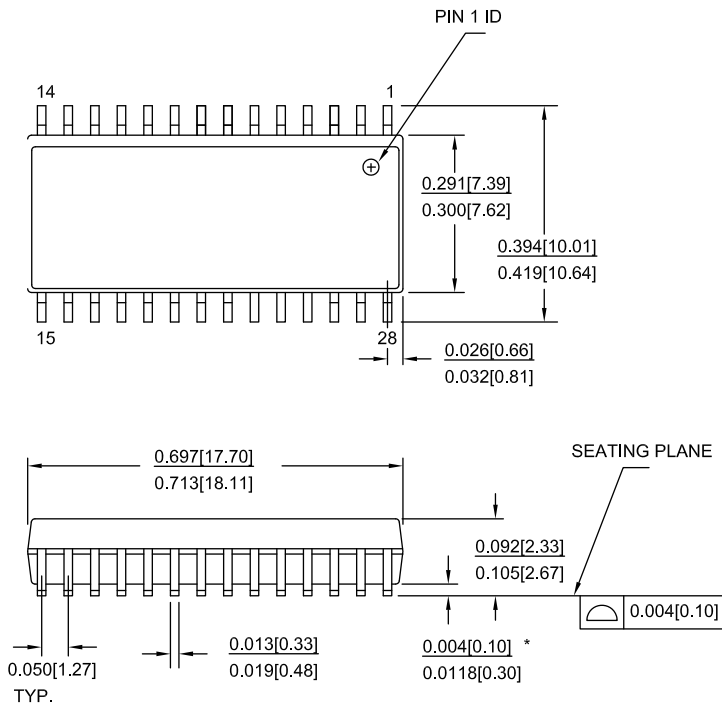

NOTE :

1. JEDEC STD REF MO-119
2. BODY LENGTH DIMENSION DOES NOT INCLUDE MOLD PROTRUSION/END FLASH, BUT DOES INCLUDE MOLD MISMATCH AND ARE MEASURED AT THE MOLD PARTING LINE. MOLD PROTRUSION/END FLASH SHALL NOT EXCEED 0.010 in (0.254 mm) PER SIDE
3. DIMENSIONS IN INCHES MIN.
MAX.

PART #	
S28.3	STANDARD PKG.
SZ28.3	LEAD FREE PKG.
SX28.3	LEAD FREE PKG.

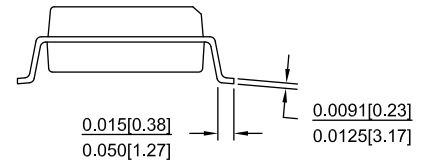

51-85026 *H

Acronyms

Acronym	Description
CPU	Central Processing Unit
CMOS	Complementary Metal Oxide Semiconductor
JEDEC	Joint Electron Devices Engineering Council
JESD	JEDEC Standards
EIA	Electronic Industries Alliance
F-RAM	Ferroelectric Random Access Memory
I/O	Input/Output
MCU	Microcontroller Unit
MPU	Microprocessor Unit
RoHS	Restriction of Hazardous Substances
R/W	Read and Write
SOIC	Small Outline Integrated Circuit
SRAM	Static Random Access Memory

Document Conventions

Units of Measure

Symbol	Unit of Measure
°C	degree Celsius
Hz	hertz
kHz	kilohertz
kΩ	kilohm
MHz	megahertz
μA	microampere
μF	microfarad
μs	microsecond
mA	milliampere
ms	millisecond
MΩ	megaohm
ns	nanosecond
Ω	ohm
%	percent
pF	picofarad
V	volt
W	watt

Document History Page

Document Title: FM1808B, 256-Kbit (32 K x 8) Byte-wide F-RAM Memory				
Document Number: 001-86209				
Rev.	ECN No.	Orig. of Change	Submission Date	Description of Change
**	3912933	GVCH	02/25/2013	New spec
*A	4000965	GVCH	05/15/2013	Added Appendix A - Errata for FM1808B
*B	4045491	GVCH	06/30/2013	All errata items are fixed and the errata is removed.
*C	4274813	GVCH	03/10/2014	Converted to Cypress standard format Changed datasheet status from "Preliminary to Final" Changed endurance value from 10 ¹² to 10 ¹⁴ cycles Updated Maximum Ratings table - Removed Moisture Sensitivity Level (MSL) - Added junction temperature and latch up current Updated Data Retention and Endurance table Added Thermal Resistance table Removed Package Marking Scheme (top mark)
*D	4562106	GVCH	11/05/2014	Added related documentation hyperlink in page 1. Updated package diagram 51-85026 to current version.

Sales, Solutions, and Legal Information

Worldwide Sales and Design Support

Cypress maintains a worldwide network of offices, solution centers, manufacturer's representatives, and distributors. To find the office closest to you, visit us at [Cypress Locations](#).

Products

Automotive	cypress.com/go/automotive
Clocks & Buffers	cypress.com/go/clocks
Interface	cypress.com/go/interface
Lighting & Power Control	cypress.com/go/powerpsoc cypress.com/go/plc
Memory	cypress.com/go/memory
PSoC	cypress.com/go/psoc
Touch Sensing	cypress.com/go/touch
USB Controllers	cypress.com/go/USB
Wireless/RF	cypress.com/go/wireless

PSoC[®] Solutions

[psoc.cypress.com/solutions](#)
[PSoC 1](#) | [PSoC 3](#) | [PSoC 4](#) | [PSoC 5LP](#)

Cypress Developer Community

[Community](#) | [Forums](#) | [Blogs](#) | [Video](#) | [Training](#)

Technical Support

[cypress.com/go/support](#)

© Cypress Semiconductor Corporation, 2013-2014. The information contained herein is subject to change without notice. Cypress Semiconductor Corporation assumes no responsibility for the use of any circuitry other than circuitry embodied in a Cypress product. Nor does it convey or imply any license under patent or other rights. Cypress products are not warranted nor intended to be used for medical, life support, life saving, critical control or safety applications, unless pursuant to an express written agreement with Cypress. Furthermore, Cypress does not authorize its products for use as critical components in life-support systems where a malfunction or failure may reasonably be expected to result in significant injury to the user. The inclusion of Cypress products in life-support systems application implies that the manufacturer assumes all risk of such use and in doing so indemnifies Cypress against all charges.

Any Source Code (software and/or firmware) is owned by Cypress Semiconductor Corporation (Cypress) and is protected by and subject to worldwide patent protection (United States and foreign), United States copyright laws and international treaty provisions. Cypress hereby grants to licensee a personal, non-exclusive, non-transferable license to copy, use, modify, create derivative works of, and compile the Cypress Source Code and derivative works for the sole purpose of creating custom software and or firmware in support of licensee product to be used only in conjunction with a Cypress integrated circuit as specified in the applicable agreement. Any reproduction, modification, translation, compilation, or representation of this Source Code except as specified above is prohibited without the express written permission of Cypress.

Disclaimer: CYPRESS MAKES NO WARRANTY OF ANY KIND, EXPRESS OR IMPLIED, WITH REGARD TO THIS MATERIAL, INCLUDING, BUT NOT LIMITED TO, THE IMPLIED WARRANTIES OF MERCHANTABILITY AND FITNESS FOR A PARTICULAR PURPOSE. Cypress reserves the right to make changes without further notice to the materials described herein. Cypress does not assume any liability arising out of the application or use of any product or circuit described herein. Cypress does not authorize its products for use as critical components in life-support systems where a malfunction or failure may reasonably be expected to result in significant injury to the user. The inclusion of Cypress' product in a life-support systems application implies that the manufacturer assumes all risk of such use and in doing so indemnifies Cypress against all charges.

Use may be limited by and subject to the applicable Cypress software license agreement.