

CIRCUIT SIZE	DIM. "A"	DIM. "B"	DIM. "C"	DIM. "D"
2	.606 (15.40)	N.A.	.213 (5.40)	.354 (9.00)
4	.772 (19.60)	.165 (4.20)	.378 (9.60)	.520 (13.20)
6	.937 (23.80)	.331 (8.40)	.543 (13.80)	.685 (17.40)
8	1.102 (28.00)	.496 (12.60)	.709 (18.00)	.850 (21.60)
10	1.268 (32.20)	.661 (16.80)	.874 (22.20)	1.016 (25.80)
12	1.433 (36.40)	.827 (21.00)	1.039 (26.40)	1.181 (30.00)
14	1.598 (40.60)	.992 (25.20)	1.205 (30.60)	1.346 (34.20)
16	1.764 (44.80)	1.157 (29.40)	1.370 (34.80)	1.512 (38.40)
18	1.929 (49.00)	1.323 (33.60)	1.535 (39.00)	1.677 (42.60)
20	2.094 (53.20)	1.488 (37.80)	1.701 (43.20)	1.843 (46.80)
22	2.260 (57.40)	1.654 (42.00)	1.866 (47.40)	2.008 (51.00)
24	2.425 (61.60)	1.819 (46.20)	2.031 (51.60)	2.173 (55.20)

NOTES:

- MATERIALS:  
HOUSING MATERIAL OPTIONS: SEE CHART FOR SPECIFIC PART  
 NYLON (PA66), UNFILLED, UL94V-2, COLOR: NATURAL  
 NYLON (PA66), UNFILLED, UL94V-2, COLOR: BLACK  
 NYLON (PA66), UNFILLED, UL94V-0, COLOR: NATURAL  
 NYLON (PA66), UNFILLED, UL94V-0, COLOR: BLACK  
 TERMINALS: BRASS
  - FINISH (PLATING) OPTIONS: SEE CHART FOR SPECIFIC PART  
 \*GS\* = 0.00076/(.000030) MIN. SELECT GOLD AND  
 0.00254/(.0000100) SELECT MATTE TIN OVER  
 0.00127/(.000050) MIN. NICKEL  
 \*MS\* = 0.00254/(.000100) MIN. MATTE TIN OVER  
 0.00127/(.000050) MIN. NICKEL
  - PRODUCT SPECIFICATION: PS-5556-001
  - PACKAGING: SEE CHART: BULK PER PK-5569-002  
 TRAY PER PK-5569-003
- △ CIRCUITS SHOWN PROVIDE THE MAKE-FIRST/BREAK-LAST FEATURE. SEE CHARTS ON SHEETS 3 & 4 FOR SPECIFIC CIRCUIT LOCATIONS.
- PART MATES WITH MINI-FIT JR. RECEPTACLE #5557.
  - CONNECTORS ARE NOT TO BE MATED OR UNMATED WHILE CIRCUITS ARE LIVE.
  - PARTS ARE NOT DESIGNED FOR CURRENT SHARING.
  - DISCOLORATION IN THE BANDOLIER CARRIER AREA OF THE PIN IS INHERENT TO THE PLATING PROCESS AND IS DUE TO THE MASKING EFFECT OF THE CARRIER. THIS DISCOLORATION, IF PRESENT, IS IN A NON-FUNCTIONAL AREA OF THE PIN AND WILL NOT EFFECT THE PERFORMANCE OF THE HEADER ASSEMBLY.
  - PART CONFORMS TO CLASS "B" REQUIREMENTS OF COSMETIC SPECIFICATION PS-45499-002.
  - FORMING MARKS ARE ACCEPTABLE.

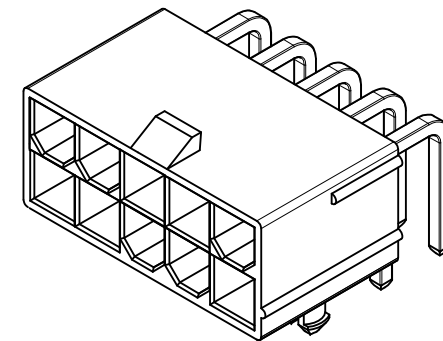

ADD -0039 EC NO: UCP2014-5058 DRWIN: DFOX 2014/06/02 CHKD: JBEL 2014/06/02 APPR: FSMITH 2014/06/05	QUALITY SYMBOLS ▽=0 ▽=0 ▽=0	GENERAL TOLERANCES (UNLESS SPECIFIED)		DIMENSION STYLE MM/IN		SCALE 4:1	DESIGN UNITS METRIC	THIRD ANGLE PROJECTION		
				DRAWN BY POLGAR		DATE 1998/01/23		TITLE <b>MINI-FIT JR          RIGHT ANGLE HEADER ASSY          CUSTOM HEADERS</b> <b>molex</b> DOCUMENT NO. <b>SD-44130-001</b> SHEET NO. <b>1 OF 4</b>		
				CHECKED BY BANDURA		DATE 1998/01/28				
				APPROVED BY FSMITH		DATE 2011/05/18				
				MATERIAL NO.		DOCUMENT NO.				
		SIZE C		THIS DRAWING CONTAINS INFORMATION THAT IS PROPRIETARY TO MOLEX INCORPORATED AND SHOULD NOT BE USED WITHOUT WRITTEN PERMISSION						

### HOUSING WITH PEGS

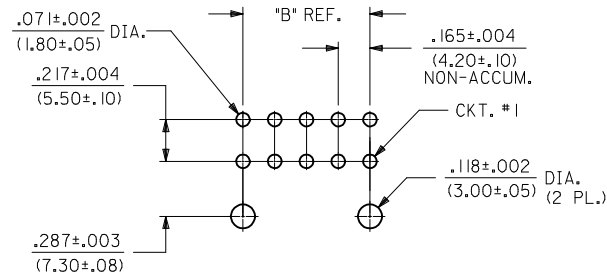
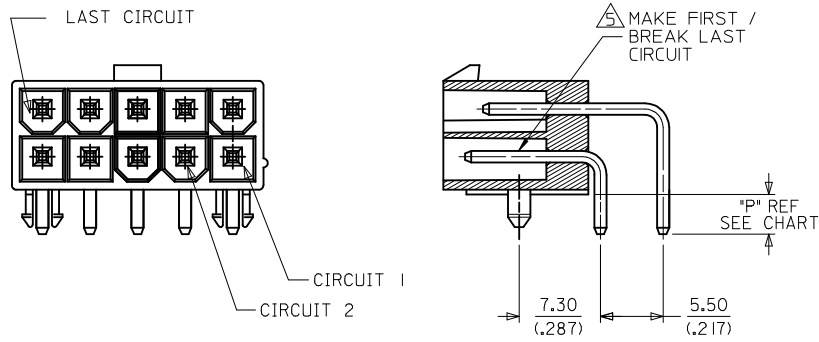

RECOMMENDED HOLE LAYOUT FOR  
.070/(1.78) MAX. THICK P.C. BOARD.  
(PEG MOUNT)

### HOUSING WITH FLANGE

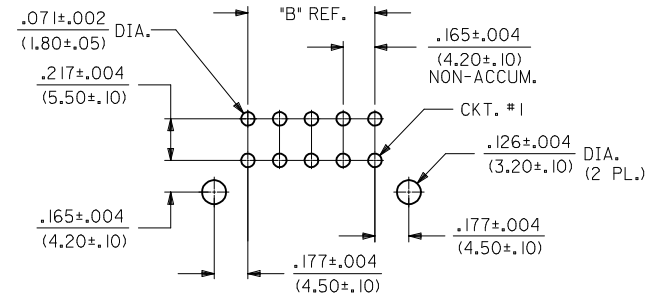
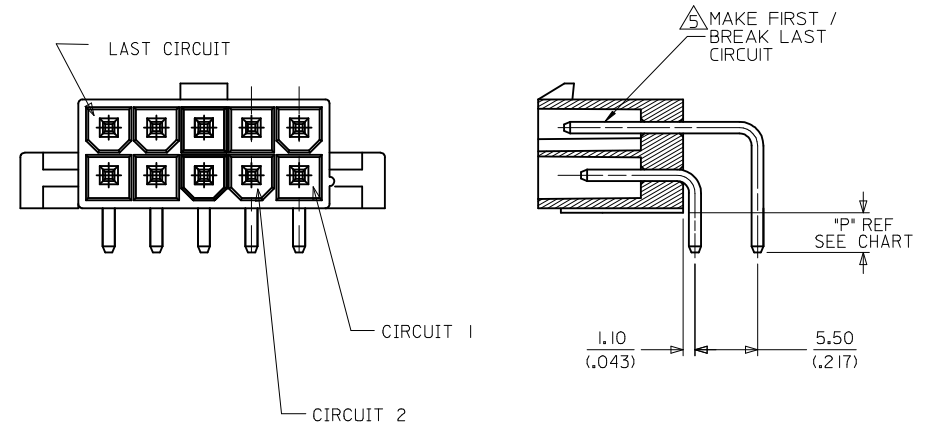

RECOMMENDED HOLE LAYOUT FOR  
.070/(1.78) MAX. THICK P.C. BOARD.  
(FLANGE MOUNT)

SEE SHEET 1 EC NO: UCP2014-5058 DRWN: JDOX 2014/06/02 CHKD: JBELL 2014/06/02 APPR: FSMITH 2014/06/05	QUALITY SYMBOLS	GENERAL TOLERANCES (UNLESS SPECIFIED)	DIMENSION STYLE	SCALE	DESIGN UNITS	THIRD ANGLE PROJECTION
	▽=0	mm INCH	MM/IN	4:1	METRIC	
	▽=0	4 PLACES ± --- ± ---	DRAWN BY POLGAR DATE 1998/01/23	TITLE		
	▽=0	3 PLACES ± --- ± .15	CHECKED BY BANDURA DATE 1998/01/28	MINI-FIT JR RIGHT ANGLE HEADER ASSY CUSTOM HEADERS		
	▽=0	2 PLACES ± 0.38 ± ---	APPROVED BY FSMITH DATE 2011/05/18			
	1 PLACE ± --- ± ---	MATERIAL NO.	SEE CHART	DOCUMENT NO.	SD-44130-001	SHEET NO. 2 OF 4
	0 PLACE ± --- ± ---	DRAFT WHERE APPLICABLE MUST REMAIN WITHIN DIMENSIONS				
		ANGULAR ±1/2°				
		THIS DRAWING CONTAINS INFORMATION THAT IS PROPRIETARY TO MOLEX INCORPORATED AND SHOULD NOT BE USED WITHOUT WRITTEN PERMISSION				

13		12		11		10		9		8		7		6		5		4		3		2		1					
MATERIAL NUMBER	HOUSING MAT'L/COLOR	NO OF CKT	HOUSING OPTION	PKG	FINISH SEE NOTE #2	PIN IDENTIFICATION CODE / CIRCUIT LOCATION (SEE CHART BELOW) V = VOID																							
						CKT 1	CKT 2	CKT 3	CKT 4	CKT 5	CKT 6	CKT 7	CKT 8	CKT 9	CKT 10	CKT 11	CKT 12	CKT 13	CKT 14	CKT 15	CKT 16	CKT 17	CKT 18	CKT 19	CKT 20	CKT 21	CKT 22	CKT 23	CKT 24
44130-0001	NYLON 94V-2/BLACK	06	PEG	TRAY	MS	1	1	1	1	2	1																		
44130-0002	NYLON 94V-2/BLACK	08	PEG	TRAY	MS	2	1	1	1	1	1	1																	
44130-0003	NYLON 94V-0/BLACK	08	PEG	TRAY	MS	2	1	1	1	1	1	1																	
44130-0004	NYLON 94V-0/BLACK	06	PEG	TRAY	MS	1	1	1	1	2	1																		
44130-0006	NYLON 94V-0/NATURAL	04	PEG	BULK	MS	2	3	2	2																				
44130-0007	NYLON 94V-0/NATURAL	06	PEG	BULK	MS	2	1	1	2	2	2																		
44130-0008	NYLON 94V-0/NATURAL	10	FLANGES	BULK	MS	4	4	4	4	4	4	4	4	4															
44130-0009	NYLON 94V-0/NATURAL	06	PEG	TRAY	MS	V	1	1	2	2	2																		
44130-0013	NYLON 94V-2/NATURAL	06	FLANGES	TRAY	MS	2	2	2	1	2	2																		
44130-0015	NYLON 94V-2/NATURAL	24	PEG	TRAY	MS	2	2	1	1	1	1	1	1	1	1	1	1	1	1	1	1	1	1	1	1	1			
44130-0017	NYLON 94V-0/BLACK	08	PEG	TRAY	MS	1	2	1	1	1	1	1	1																
44130-0018	NYLON 94V-0/NATURAL	02	PEG	BULK	MS	2	1																						
44130-0024	NYLON 94V-0/NATURAL	08	PEG	BULK	GS	2	2	5	2	2	5	2	2																
44130-0026	NYLON 94V-2/NATURAL	04	PEG	BULK	MS	8	8	8	8																				
44130-0027	NYLON 94V-0/NATURAL	02	PEG	BULK	MS	5	5																						
44130-0028	NYLON 94V-0/NATURAL	04	PEG	BULK	MS	8	8	8	8																				
44130-0030	NYLON 94V-0/NATURAL	06	PEG	TRAY	GS	2	1	2	2	2	2																		
44130-0031	NYLON 94V-0/NATURAL	08	PEG	BULK	MS	9	9	9	9	9	9	9																	

PIN ID	MATING CONFIGURATION	DIM P (PCB TAIL LENGTH)	PIN ID	MATING CONFIGURATION	DIM P (PCB TAIL LENGTH)
1	MAKE FIRST/BREAK LAST (LONGER PIN)	3.5 (.14)	9	STANDARD MATING	8.0 (.31)
2	STANDARD MATING	3.5 (.14)			
3	MAKE FIRST/BREAK LAST (LONGER PIN)	4.9 (.19)			
4	STANDARD MATING	6.0 (.24)			
5	MAKE FIRST/BREAK LAST (LONGER PIN)	4.2 (.17)			
6	STANDARD MATING	4.2 (.17)			
8	STANDARD MATING	5.30 (.209)			

<b>SEE SHEET 1</b> EC NO: UCP2014-5058 DRWN: JFOX 2014/06/02 CHKD: JHELL 2014/06/02 APPR: FSMITH 2014/06/05 F5	QUALITY SYMBOLS 	GENERAL TOLERANCES (UNLESS SPECIFIED)		DIMENSION STYLE MM/IN		SCALE 1:1	DESIGN UNITS METRIC	THIRD ANGLE PROJECTION			
		4 PLACES ± --- ± ---	3 PLACES ± --- ± .15	2 PLACES ± 0.38 ± ---	1 PLACE ± --- ± ---	0 PLACE ± ±	DRAWN BY POLGAR	DATE 1998/01/23	TITLE <b>MINI-FIT JR RIGHT ANGLE HEADER ASSY CUSTOM HEADERS</b>		
		DRAFT WHERE APPLICABLE MUST REMAIN WITHIN DIMENSIONS					CHECKED BY BANDURA	DATE 1998/01/28			
		ANGULAR ±1/2°					APPROVED BY FSMITH	DATE 2011/05/18	<b>molex</b> DOCUMENT NO. <b>SD-44130-001</b>		
		SEE CHART					MATERIAL NO.				
THIS DRAWING CONTAINS INFORMATION THAT IS PROPRIETARY TO MOLEX INCORPORATED AND SHOULD NOT BE USED WITHOUT WRITTEN PERMISSION											

MATERIAL NUMBER	HOUSING MAT'L/COLOR	NO OF CKT	HOUSING OPTION	PKG	FINISH SEE NOTE #2	PIN IDENTIFICATION CODE / CIRCUIT LOCATION (SEE CHART BELOW)																							
						CKT 1	CKT 2	CKT 3	CKT 4	CKT 5	CKT 6	CKT 7	CKT 8	CKT 9	CKT 10	CKT 11	CKT 12	CKT 13	CKT 14	CKT 15	CKT 16	CKT 17	CKT 18	CKT 19	CKT 20	CKT 21	CKT 22	CKT 23	CKT 24
44130-0032	NYLON 94V-0/NATURAL	16	PEG	TRAY	MS	8	8	8	8	8	8	8	8	8	8	8	8	8	8	8									
44130-0036	NYLON 94V-2/NATURAL	06	PEG	TRAY	MS	2	1	2	2	1	2																		
44130-0037	NYLON 94V-0/NATURAL	06	PEG	TRAY	MS	2	V	2	2	V	2																		
44130-0038	NYLON 94V-2/NATURAL	10	PEG	TRAY	MS	2	V	2	V	2	2	V	2	V	2														
44130-0039	NYLON 94V-0/NATURAL	04	PEG	TRAY	MS	1	2	2	2																				

PIN ID	MATING CONFIGURATION	DIM P (PCB TAIL LENGTH)
1	MAKE FIRST/BREAK LAST (LONGER PIN)	3.5 (.14)
2	STANDARD MATING	3.5 (.14)
3	MAKE FIRST/BREAK LAST (LONGER PIN)	4.9 (.19)
4	STANDARD MATING	6.0 (.24)
5	MAKE FIRST/BREAK LAST (LONGER PIN)	4.2 (.17)
6	STANDARD MATING	4.2 (.17)
8	STANDARD MATING	5.30 (.209)

**SEE SHEET 1**  
 EC NO: UCP2014-5058  
 2014/06/02  
 DRWN: JDOX  
 2014/06/02  
 CHKD: JBELL  
 2014/06/05  
 APPR: FSMITH

DESCRIPTION  
 QUALITY SYMBOLS

GENERAL TOLERANCES (UNLESS SPECIFIED)

	mm	INCH
4 PLACES	± .15	± .005
3 PLACES	± .15	± .005
2 PLACES	± 0.38	± .015
1 PLACE	± .15	± .005
0 PLACE	± .15	± .005

ANGULAR ±1/2°  
 DRAFT WHERE APPLICABLE MUST REMAIN WITHIN DIMENSIONS

DIMENSION STYLE		SCALE		DESIGN UNITS	THIRD ANGLE PROJECTION	
MM/IN		1:1		METRIC		
DRAWN BY	DATE	CHECKED BY	DATE	MINI-FIT JR RIGHT ANGLE HEADER ASSY CUSTOM HEADERS <b>molex</b>		
POLGAR	1998/01/23	BANDURA	1998/01/28			
APPROVED BY	DATE	FSMITH	2011/05/18			
MATERIAL NO.		DOCUMENT NO.				
SEE CHART		SD-44130-001		SHEET NO. 4 OF 4		

THIS DRAWING CONTAINS INFORMATION THAT IS PROPRIETARY TO MOLEX INCORPORATED AND SHOULD NOT BE USED WITHOUT WRITTEN PERMISSION