

THIS DRAWING IS UNPUBLISHED. RELEASED FOR PUBLICATION  
 © COPYRIGHT - By - ALL RIGHTS RESERVED.

REVISIONS				
P	LTR	DESCRIPTION	DATE	APVD
AM2		REVISED PER ECO-16-014786	19OCT2016	RS MZ

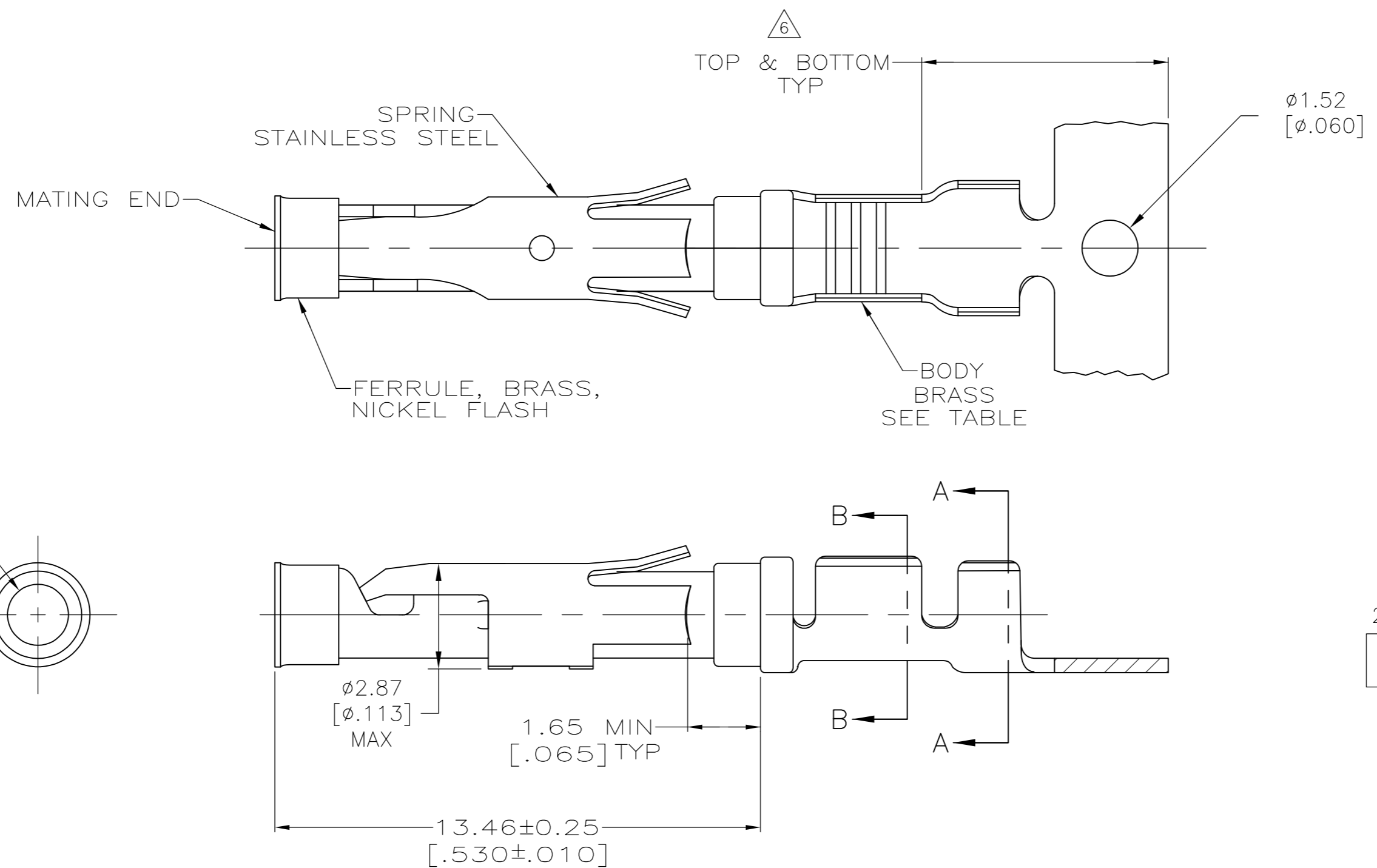

1.27 $\mu$ m [.000050] MIN TIN PER MIL-T-10727 OVER  
 0.76 $\mu$ m [.000030] MIN NICKEL PER QQ-N-290.

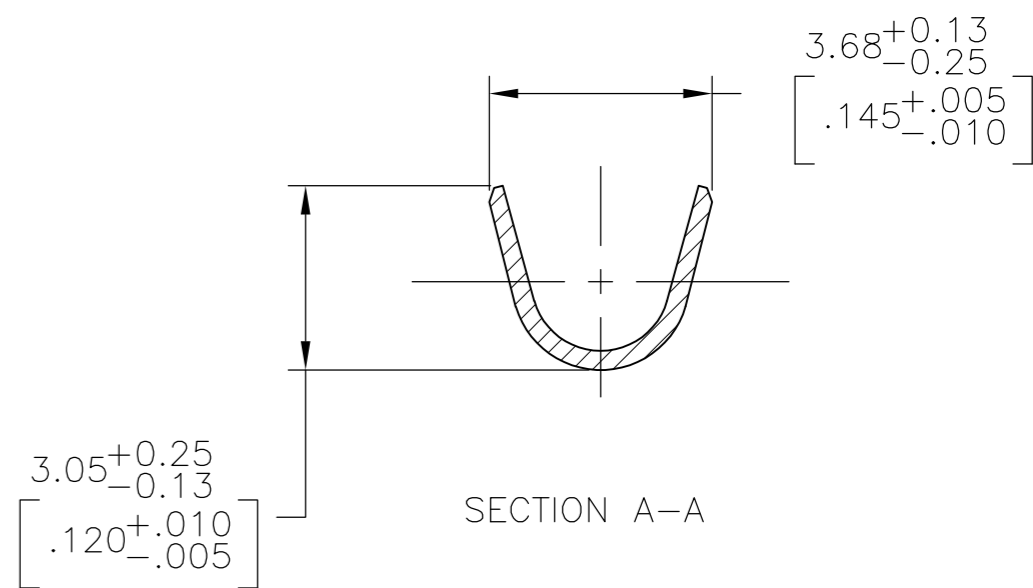
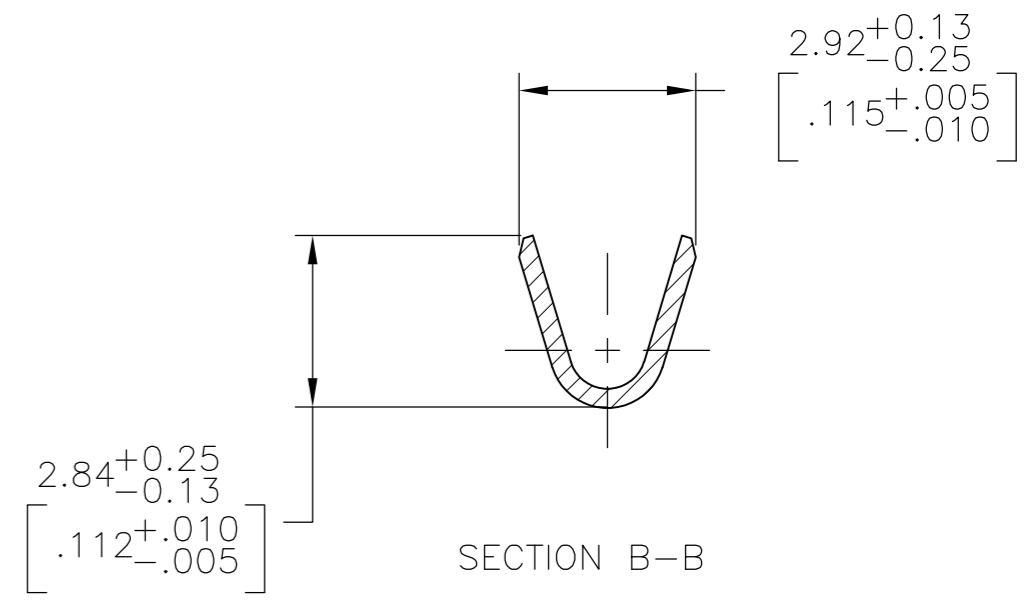
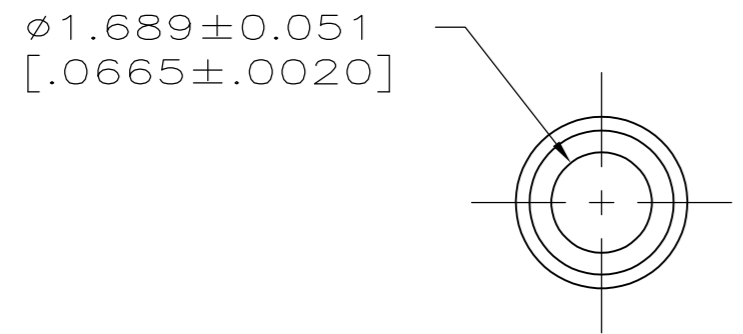

- 1 0.76 $\mu$ m [.000030] MIN GOLD PER MIL-G-45204 ON MATING END FOR A LENGTH OF 5.08 [.200] MIN WITH 1.27 $\mu$ m [.000050] MIN MATTE TIN PLATE IN WIRE CRIMP AREA, BOTH OVER 0.76 $\mu$ m [.000030] MIN NICKEL PER QQ-N-290.
- 2 1.27 $\mu$ m [.000050] MIN TIN-LEAD PER MIL-T-10727 OVER 0.76 $\mu$ m [.000030] MIN NICKEL PER QQ-N-290.
- 3 0.76 $\mu$ m [.000030] MIN GOLD PER MIL-G-45204 ON MATING END FOR A LENGTH OF 5.08 [.200] MIN WITH A UNIFORM GRADIENT TO 0.25 $\mu$ m [.000010] MIN GOLD PER MIL-G-45204 ON THE REMAINDER OVER 0.76 $\mu$ m [.000030] MIN NICKEL PER QQ-N-290.
- 4 0.38 $\mu$ m [.000015] MIN GOLD PER MIL-G-45204 ON MATING END FOR A LENGTH OF 5.08 [.200] MIN WITH 1.27 $\mu$ m [.000050] MIN MATTE TIN PLATE IN WIRE CRIMP AREA, BOTH OVER 0.76 $\mu$ m [.000030] MIN NICKEL PER QQ-N-290.
- 5 1.27 $\mu$ m [.000050] MIN GOLD PER MIL-G-45204 ON MATING END FOR A LENGTH OF 5.08 [.200] MIN WITH GOLD FLASH ON REMAINDER OVER 1.90 $\mu$ m [.000075] MIN NICKEL PER QQ-N-290.
- 6 GOLD PLATING NEED NOT APPEAR IN THIS AREA EXCEPT 1-66100-3 HAS GOLD PLATING ON INSULATION BARREL.
- 7 REVERSE REELED FOR MINI-APPLICATOR.
- 8 ALL PART NUMBERS ON THIS DRAWING HAVE APPLICATION TOOLING AVAILABLE TO CRIMP 18-16 WIRE AWG WITH AN INSULATION RANGE OF  $\phi 2.03$ -2.54 [.080-.100]. ADDITIONALLY, LOOSE PIECE AND REVERSE REELED PART NUMBERS HAVE APPLICATION TOOLING AVAILABLE TO CRIMP 0.75mm<sup>2</sup> WIRE WITH AN INSULATION RANGE OF  $\phi 1.35$ -1.65 [.053-.065] OR 1.0mm<sup>2</sup> WIRE WITH AN INSULATION RANGE OF  $\phi 1.45$ -1.80 [.057-.071].
- 9 0.38 $\mu$ m [.000015] MIN GOLD PER MIL-G-45204 ON MATING END FOR A LENGTH OF 5.08 [.200] MIN, 1.27 $\mu$ m [.000050] MIN TIN-LEAD PER MIL-T-10727 FOR A LENGTH OF 5.69 [.224] MIN ON OPPOSITE END, BOTH OVER 1.27 $\mu$ m [.000050] MIN NICKEL PER QQ-N-290 ON ENTIRE CONTACT.

SUPERCEDED BY 66100-8

OBSOLETE	EUROPE	7	10	NONE	—2-66100-2—
OBSOLETE		7	1	NONE	—2-66100-1—
		STANDARD	10	1-66101-9	2-66100-0
		7	10	1-66101-9	1-66100-9
		7	9	1-66101-4	—1-66100-7—
		—	5	—	—1-66100-3—
		7	1	66101-4	66100-9
		7	4	66101-3	66100-8
		7	2	66101-2	66100-7
		7	3	66101-1	66100-6
		STANDARD	1	66101-4	66100-4
		STANDARD	4	66101-3	66100-3
		STANDARD	2	66101-2	66100-2
		STANDARD	3	66101-1	66100-1
	TE ASSEMBLY LOCATION	REELING	BODY FINISH	LOOSE PIECE REF	PART NO.

THIS DRAWING IS A CONTROLLED DOCUMENT.

DWN V. FURLER 11JUL03		NAME	SOCKET ASSEMBLY, .062, TYPE III+
CHK G. STEINHAUER 11JUL03		SIZE	A2
APVD G. STEINHAUER 11JUL03		CAGE CODE	00779
PRODUCT SPEC		DRAWING NO	C=66100
DIMENSIONS: mm [INCHES]	TOLERANCES UNLESS OTHERWISE SPECIFIED:	APPLICATION SPEC	RESTRICTED TO
0 PLC ± -	1 PLC ± -	—	—
2 PLC ± 0.13 [.005]	3 PLC ± -	—	—
4 PLC ± -	ANGLES ± -	—	—
MATERIAL SEE CALLOUTS	FINISH SEE CALLOUTS	WEIGHT	SCALE 8:1 SHEET 1 of 1 REV AM2
CUSTOMER DRAWING			