

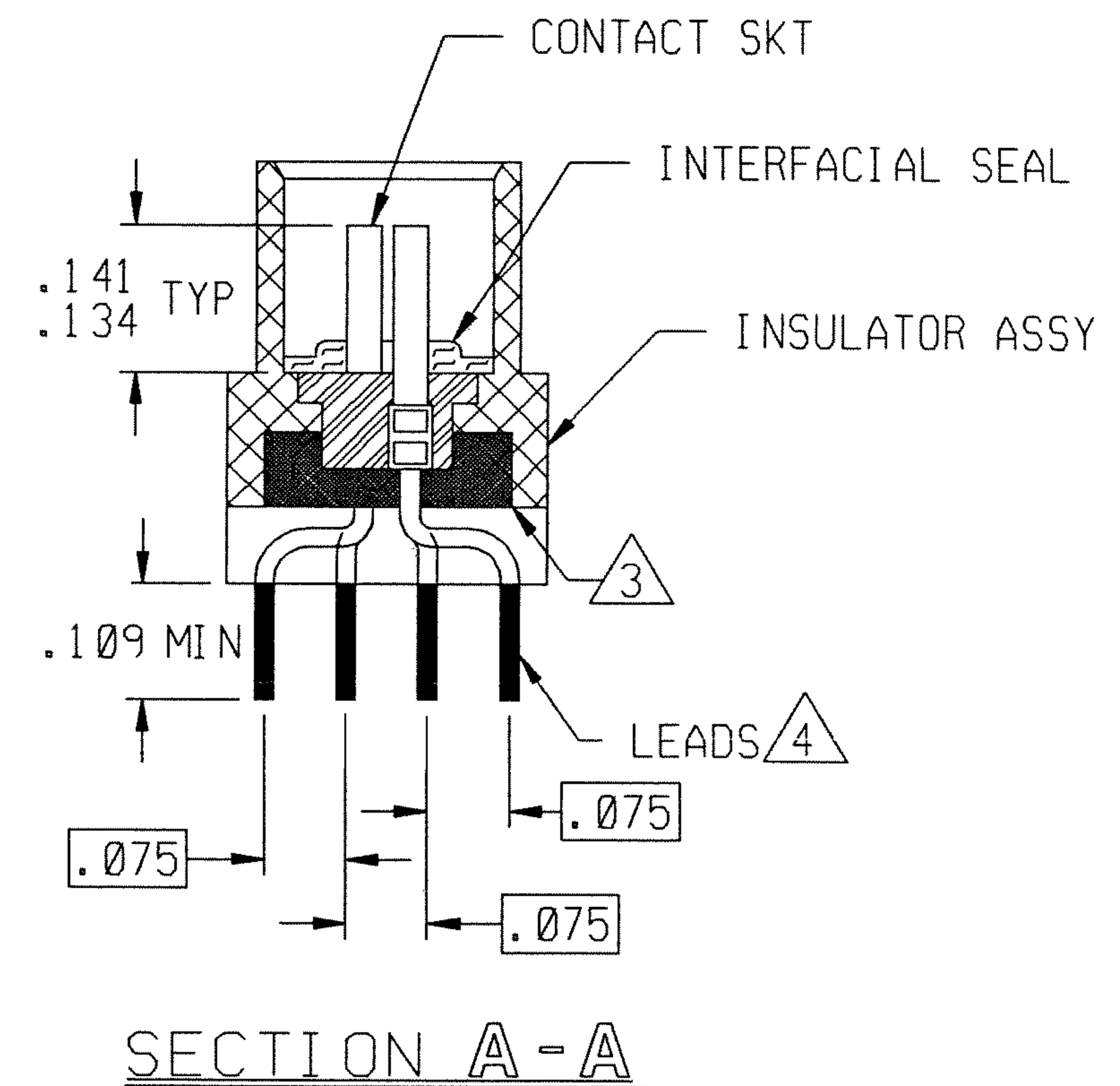

| REVISION | | | | | |
|----------|-----|-------|---------------------------|----------|--------------------|
| ZONE | LTR | ECN | DESCRIPTION | DATE | APPROVED |
| | B | 38334 | UPDATE CONN. DESCRIPTION. | 11/20/83 | <i>[Signature]</i> |
| | C | | UPDATE PER ECO-10-017486 | 8/25/10 | PJS |

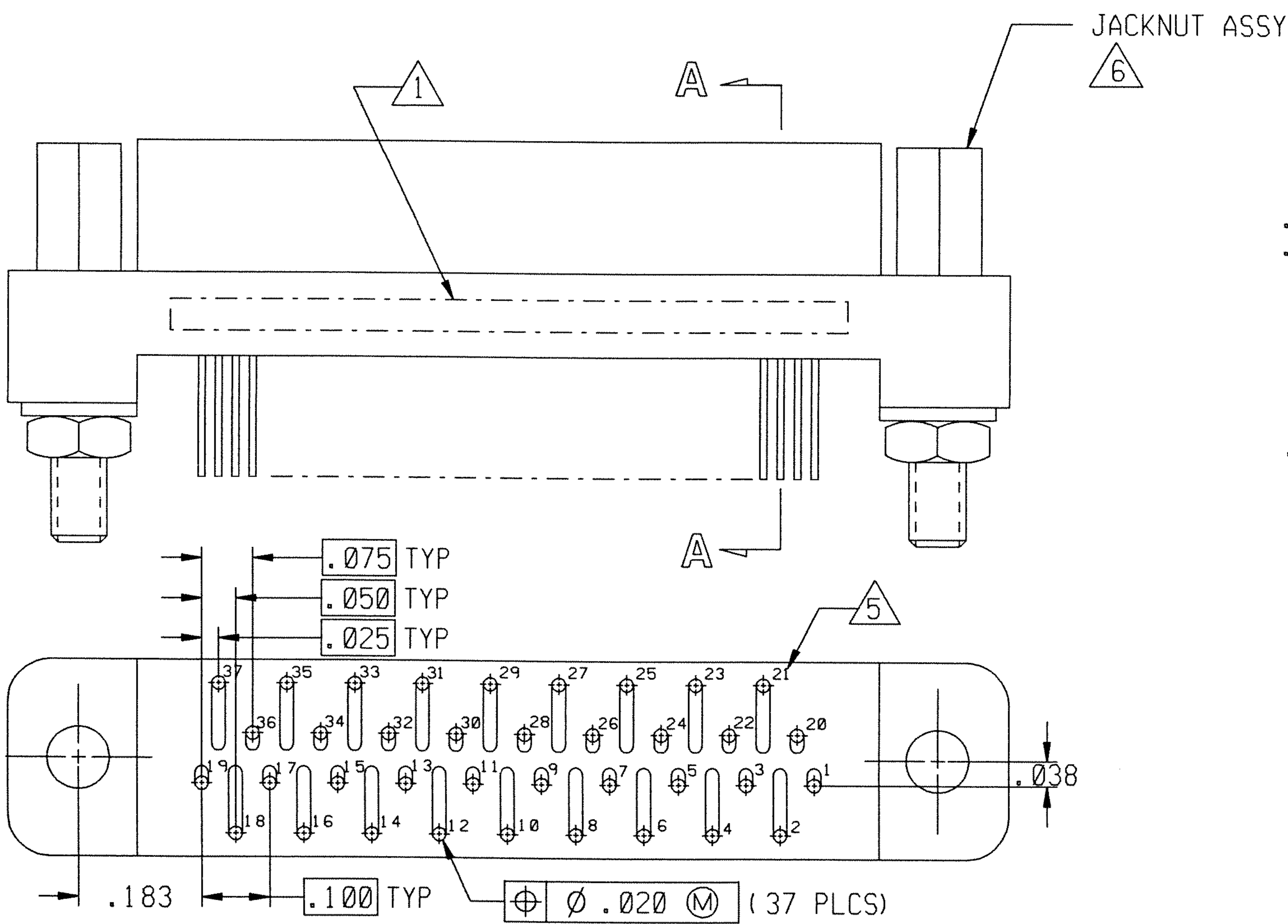
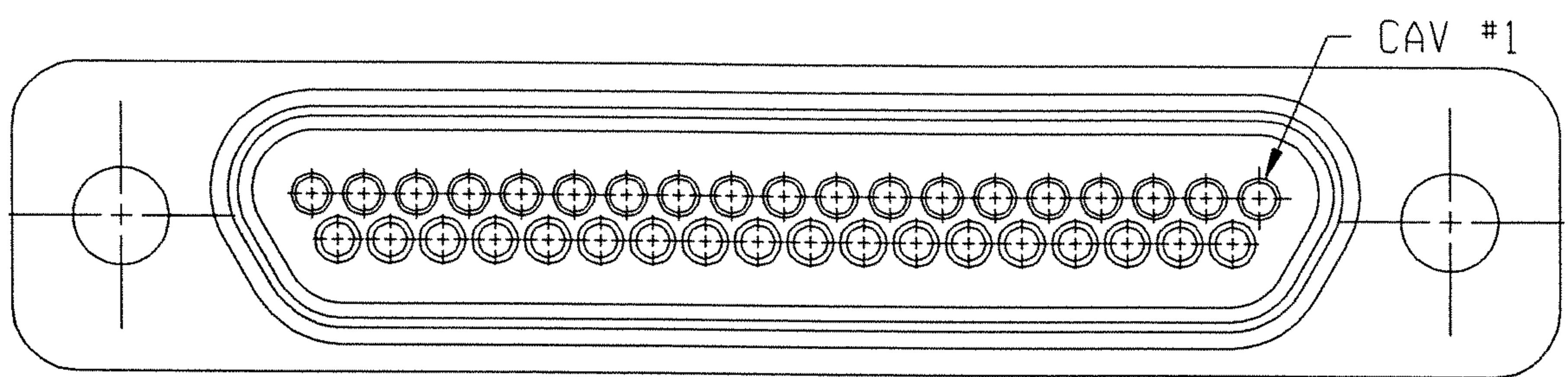

- NOTES: UNLESS OTHERWISE SPECIFIED
- 1. MARK PER MEP 203-12 IN APPROX. LOCATION SHOWN
 - 2. CRIMP LEADS INTO CONTACTS PER MEP 302-05.
 - 3. EPOXY AS SHOWN.
 - 4. TERMINAL WIRES ARE TO BE SOLDER DIPPED UP TO THE MOUNTING SURFACE MINIMUM.
 - 5. LEAD IDENTIFICATIONS ARE FORE REF ONLY. DO NOT APPEAR ON THE PART.
 - 6. JACKNUT ASSEMBLIES ARE INSTALLED ONTO CONNECTOR.

| | | | | | |
|---|---|-----------|---|-------------------------------|--|
| UNLESS OTHERWISE SPECIFIED DIMENSIONS ARE IN INCHES. TOLERANCE ARE: FRACTIONS: ± 1/8 DECIMALS: .XX ± .01 ANGLES: ± 2° .XXX ± .005 | APPROVALS | |  MICRODOT CONNECTORS A DIVISION OF UNI-STAR INDUSTRIES INC. 306 PASADENA AVE., SO. PASADENA, CA 91030 | PROD CODE 845 CODE M | |
| | SIGNATURE | DATE | | | METAL SHELL "D" CONNECTOR RCPT MCK-**-P-37SST2 094-5607-7001 |
| | DRAWN <i>[Signature]</i> | 3/7/97 | | | |
| MATERIAL: | CHECKED | PRO. ENG. | SIZE: B CODE IDENT NO.: 98278 DRAWING NO.: 4-1532223-0 | | |
| FINISH: | THIS DOCUMENT IS THE PROPERTY OF MICRODOT CONNECTORS, A DIVISION OF UNI-STAR INDUSTRIES INC. USE OF THIS DOCUMENT OR ANY PART THEREOF IS STRICTLY FORBIDDEN WITHOUT THE EXPRESS WRITTEN PERMISSION OF MICRODOT CONNECTORS, A DIVISION OF UNI-STAR INDUSTRIES INC. | | SCALE: NONE | SHEET 1 OF 1 | |