

LEMO's Fiber Optic Connectors ●

Single-mode, Multi-mode, and
Hybrid Fiber Optic Applications



Expect Success. Spec LEMO®



• A Global Leader

Since its beginning in Switzerland in 1946, LEMO® has evolved into a worldwide leader in the design and manufacture of circular connectors, with products sold in more than 80 countries.

Today, LEMO offers a product line for almost any application, from medical equipment to test and measurement instrumentation.

• LEMO Means "Quality"

The name LEMO has become synonymous with quality and customer service in the connector industry, setting standards that others strive to meet. Our connectors are designed in an ISO 9001 business environment, ensuring the highest quality products for our customers.

• LEMO – We Deliver Reliability

Ask for LEMO connectors for any application where quality, safety and ruggedness are essential; where reliability is critical or where connectors are frequently engaged and disengaged, even in the toughest environments.

LEMO Connectors offer a unique combination of benefits:

Original QUICK-LOK™ push-pull, self-latching system saves space and time while ensuring durable connections.

Precision construction from machined brass, stainless steel or aluminum ensures safety and uniform mating.

Gold plated contacts assure excellent electrical performance.

Collet-type strain relief securely grips circumference of any round cable, protecting connection even under extreme stress.

Bend relief option offers additional cable protection, including color-coding for easy identification.



Custom Design

If we don't have it, we'll build it. Although we offer the most extensive product line in the industry, we understand that some application needs are unique. If we don't have exactly what you need, LEMO will design and build a connector that's just right for your application.

Cable Assembly

Expand the quality of the connector to the cable assembly with our one-stop shop value-added service. LEMO's skilled technicians build and test assemblies to your specifications.

Customer Support

Customer Support when you need it. Only LEMO offers extended customer service hours so you get technical support when you need it. LEMO's Customer Support Team includes in-house Product Specialists, plus a nationwide network of sales representatives and distributors.



LEMO®

● Table of Contents

General Information	LEMO's Product Line	3
	Characteristics of Primary Series	3
	LEMO's Line of Series by Types	4
	LEMO's Line of Fiber Optic Series	5
	QUICK-LOK™ Push-Pull Self-Locking System	6
General Characteristics	Outer Shell, Technical Characteristics	7
	Electrical Characteristics	8
	Insulator, Technical Characteristics	9
	Electrical Contact	10
00 Series Connectors	Introduction	17
	Interconnections	18
	Part Section Showing Internal Components	19
	Part Number Example	20
	Models	21
	Fiber Types	22
0B Series Connectors	Introduction	25
	Interconnections	26
	Part Section Showing Internal Components	27
	Part Number Example	28
	Models	29
	Fiber Types	30
0K Series Connectors	Introduction	33
	Interconnections	34
	Part Section Showing Internal Components	35
	Part Number Example	36
	Models	37
	Fiber Types	37
2B to 5B Series Connectors	Introduction	39
	Interconnections	40
	Part Section Showing Internal Components	41
	Part Number Example	42
	Models	43
	Types	56
2K to 5K Series Connectors	Introduction	39
	Interconnections	49
	Part Section Showing Internal Components	50
	Part Number Example	51
	Models	52
	Types	56

3K.93C Series Connectors	Introduction63
	Interconnections64
	Part Section Showing Internal Components65
	Part Number Example66
	Models67
	Types70
F1 Fiber Optic Contacts	Introduction76
	Part Section Showing Internal Components76
	Part Number Example76
	Models77
	Fiber Types77
F2 Fiber Optic Contacts	Introduction78
	Part Section Showing Internal Components78
	Part Number Example79
	Models79
	Types79
	Insertion and Extraction of Fiber Optic contacts81
Accessories	Insulators for Crimp Contacts84
	Crimp Contacts85
	Caps86
	Bend Relief91
	Washers and Nuts93
Tooling	Wrenches and Assembly Tools97
	Crimping Tools for Crimp Contacts100
	Tooling for type C Coax contacts102
	Fiber Optic Tooling103
	Cable Fixing107
	Preferred Fiber Optic cable types110
	Technical Tables and Conversion111
	Terms and Conditions113
	Product Safety Notice115
	Forms116

LEMO's Product Line

● Connectors, accessories and tools found in this catalog.

- Connectors**
- Single contact from 2 to 150 Amps
 - Coaxial 50 and 75 Ω
 - Coaxial 50 Ω (NIM-CAMAC)
 - Coaxial 50 Ω for frequency → 12 GHz
 - Multicoaxial 50 and 75 Ω
 - Multicontact from 2 to 66 contacts
 - High Voltage 3, 5, 8, 10, 15, 30 and 50 kV cc
 - Multi High Voltage 3, 5, and 10 kV cc
 - Triaxial 50 and 75 Ω
 - Quadrax
 - Mixed: High Voltage (HV) + Low Voltage (LV)
 - Mixed: Coax + LV
 - Mixed: Triax + LV
 - Thermocouple
 - Multithermocouple
 - Fiber optic singlemode
 - Fiber optic multimode
 - Mixed: fiber optic + LV
 - Mixed: fiber optic + coax + LV
 - Fiber optic singlemode OPTABALL®
 - Fluidic
 - Multifluidic
 - Mixed: fluidic + LV
 - Subminiature
 - Miniature
 - Plastic
 - Printed circuit board
 - Remote handling
 - Watertight
 - Sealed (pressure and/or vacuum)
 - With plastic outer shell
 - With aluminum outer shell
 - With stainless steel outer shell
 - With special radiation resistant insulator material
 - With screw thread coupling for very high pressure
 - With microswitch

- Patch Panels**
- For audio-mono applications: triax
 - For audio-mono applications: 3 contacts
 - For audio-stereo applications: quadrax
 - For audio-stereo applications: 6 contacts
 - For video applications: coax 75 Ω

- Patch Panels**
- For video HDTV applications: 3 coax 75 Ω + 2LV
 - For fiber optic applications

- Adaptors**
- For BNC, C, UHF, N, CINCH, GEN-RADIO connectors
 - For TNC, SMA connectors

- Accessories**
- Insulator for crimp contacts
 - Crimp contacts
 - Coaxial contacts
 - Triaxial contacts
 - Fiber optic contacts
 - Fiber optic ferrules
 - Caps and bend relief
 - Heatshrink boot
 - Insulating washers
 - Double plastic panel washers
 - Locking washers
 - Tapered washers
 - Hexagonal nuts
 - Conical nuts
 - Round nuts
 - Notched nuts
 - Grounding washers
 - Lead-through with cable collet

- Tooling**
- Wrenches
 - Wrenches for assembling plug
 - Assembly tool
 - Pliers
 - Tap
 - Crimping tools
 - Positioners
 - Crimping dies
 - Banding Tool
 - Extractors
 - Insertion testing tool for crimp contacts
 - Fiber optic termination workstation
 - Fiber optic polishing tools

- On request**
- Filtered connectors
 - Connectors with special alloy housing
 - Mixed special connectors
 - Assembly onto cable

Characteristics of Primary Series

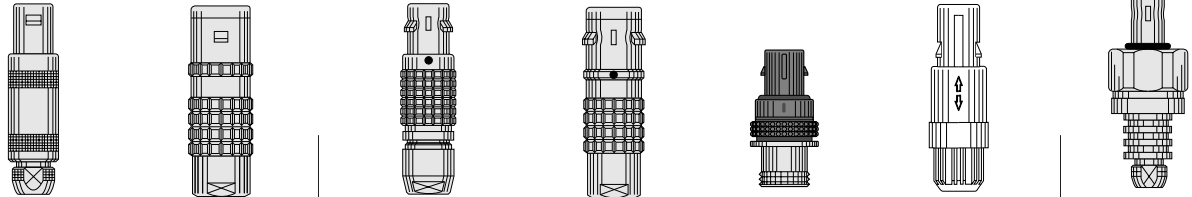

Series	STANDARD	WATERTIGHT	KEYED	KEYED WATERTIGHT		PLASTIC	SCREW
	01 (Minax)	0E to 6E	00 (multicontact)	0K to 5K	0F to 5F	REDEL® 1P	03
	00 (NIM-CAMAC)	3T	0B to 5B	2N to 5N		REDEL® 2P	0V to 5V
	00 (single contact)	4M	2G/5G			REDEL® 3P	0W to 5W
	05 / R0	REDEL® F					2U to 5U
	0S to 6S						
	0A / 4A						
	1D / 2C						
	1Y-3Y-6Y						
Latching	Push-Pull						Screw
Key	Stepped insert (Half-Moon)		Key (G) or other key-way code	Key (G) or other key-way code	Key (G) or other key-way code	Key (G) or other key-way code	Key (G) or stepped insert (Half-Moon)
Shell	Metal or plastic	Metal	Metal or plastic	Metal	Metal	Plastic	Metal
Insert	Hermaphroditic or cylindrical		Cylindrical				Hermaphroditic or cylindrical
Contact	Solder or printed circuit		Solder, crimp or printed circuit				Solder (crimp or PC)

LEMO's Line of Series by Types

Note:

- = included in this catalog
- = available but not included in this catalog.

	Series	Types																			
		Single contact	Coaxial 50 Ω	Coaxial 75 Ω	Multicontact	High Voltage	Triaxial 50 Ω	Triaxial 75 Ω	Quadrx	Multi HV	Multi Coaxial	Mixed HV+LV	Mixed Coax+LV	Mixed Triax+LV	Fiber Optic	Multi FO	Mixed FO+LV	Fluidic	Multi fluidic	Mixed fluidic+LV	Thermocouple
Hermaphroditic Keying	01		●																		
	00	●	●				●											●			
	05					●															
	R0		●																		
	0A		●	●																	
	0S	●	●		●	●	●														●
	1S	●	●	●	●	●	●														●
	2S	●	●	●	●	●	●	●				●									●
	3S	●	●	●	●	●	●	●		●		●	●								
	4S	●	●	●	●	●	●	●		●	●	●	●	●							
	5S	●	●	●	●					●	●	●	●	●							
	6S				●						●		●								
	1D								●												
	2C		●		●																
4A							●														
1Y-3Y-6Y					●																
Hermaphroditic Keying — Watertight	0E	●	●		●	●	●													●	
	1E	●	●	●	●	●	●													●	
	2E	●	●	●	●	●	●				●									●	
	3E	●	●	●	●	●	●		●		●	●									
	4E	●	●	●	●	●	●				●	●	●								
	5E	●			●				●	●	●	●	●								
	6E				●					●		●	●								
3T			●				●														
4M						●	●														
Mechanical Keying	00				●									■						●	
	0B				●									■			●			●	
	1B				●						●									●	
	2B				●					●	●	●	●	●			■		●	●	
	3B				●					●	●	●	●	●		■	■		●	●	
	4B				●					●	●	●	●	●		■	■		●	●	
	5B				●					●	●	●	●	●		■	■		●	●	
	2G				●																
5G								●													
Mechanical Keying — Watertight	0K				●									■			●			●	
	1K				●						●									●	
	2K				●					●	●	●	●			■			●	●	
	3K		●		●					●	●	●	●	●		■	■		●	●	
	4K				●				●	●	●	●	●	●		■	■		●	●	
	5K				●				●	●	●	●	●	●		■	■		●	●	
	0F to 5F				●																
3N to 5N				●																	
Plastic	1P to 3P				●							●	●				●				
Screw	03		●		●																
	0V	●	●		●		●													●	
	1V	●	●	●	●		●													●	
	2V	●	●	●	●		●	●			●									●	
	3V	●	●	●	●		●	●		●		●								●	
	4V	●	●	●	●		●	●			●	●	●							●	
	5V	●			●				●	●	●	●	●							●	
	0W to 5W				●						●	●	●	●			●			●	
	2U to 5U				●										●	●	●				

● Fiber Optic Connectors Product Line

The product line is divided into 12 series of connectors. Their main characteristics and applications are shown below.

Series	00	0B	0K	2B to 5B	2K to 5K	3K.93C
Latching	Self-latching Quick-Lok™					With «W» key-way
Shell	Metal			Metal or plastic	Metal	
Feature	Miniature		Watertight to IP68		Watertight to IP68	Watertight to IP68
Cable Construction	Single fiber			Multi fiber or Mixed optical/electrical		Mixed HDTV optical/electrical
Contact Type	F4	F3	F2	F1	F2	F2
Fiber Type	Single-mode or Multi-mode fibers ≤ 100/140µm	Multi-mode fibers ≥ 100/140µm	Single-mode or Multi-mode fibers ≤ 100/140µm	Multi-mode fibers ≥ 100/140µm	Single-mode or Multi-mode fibers ≤ 100/140µm	Single-mode or Multi-mode fibers ≤ 100/140µm
Mean insertion loss	0.10 dB (s/m) 0.25 dB (m/m)	1.13 dB	0.10 dB (s/m) 0.25 dB (m/m)	1.13 dB	0.10 dB (s/m) 0.25 dB (m/m)	0.10 dB (s/m) 0.25 dB (m/m)
Ferrule Material	Ceramic	Ceramic or metal	Ceramic	Ceramic or metal	Ceramic	Ceramic
Interface Type	Spherical with physical contact of the fiber end face (PC)	Spherical, non-contact with controlled gap of the fiber end face	Spherical with physical contact of the fiber end face (PC)	Spherical, non-contact with controlled gap of the fiber end face	Spherical with physical contact of the fiber end face (PC)	Spherical with physical contact of the fiber end face (PC)
Page	17 to 24	25 to 32	33 to 38	39 to 48	49 to 62	63 to 75

● QUICK-LOK™ Push-Pull Self-Latching System



LEMO's Original QUICK-LOK push-pull, self-latching system is renowned worldwide for its easy and quick mating and unmating features. It provides absolute security against vibration, shock or pull on the cable, and facilitates operation in a very limited space, and offers unique advantages for all applications:

Speed – Engage connectors simply and quickly by pushing plugs axially into mating receptacles. Pull on outer shell to remove plug easily.

Space Savings – Just one finger clearance on two sides is needed to engage and disengage connectors, so there's no need to twist or turn a locking ring.

Reliability – Connections are reliable and assured when locking mechanism is engaged.

Ruggedness – Sturdy design, with sealed models to various IP levels.

How QUICK-LOK™ Works

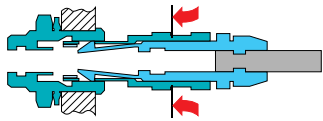
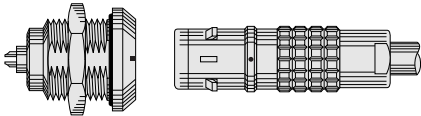

Engaging

QUICK-LOK allows the connector to be mated by simply pushing the plug straight into the receptacle.

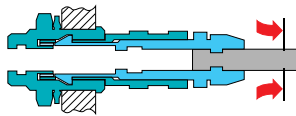

Latched

Once firmly latched, connection cannot be broken by pulling on the cable or any other component part other than the outer release sleeve.

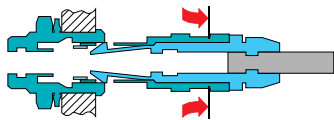

Disengaging

When required, the connector is disengaged by a single straight pull on the outer release sleeve. This first disengages the latches and then withdraws the plug from the receptacle.

Key:

Fv = average latching force.

Fd = average unmating force with axial pull on the outer release

Fa = average pull force with axial pull on the collet nut.

Latching Characteristics for 00, B and K Series Connectors

Force (N)	Series					
	00	0B	2B	3B	4B	5B
Fv	9	10	15	17	39	48
Fd	7	8	12	14	38	38
Fa	120	250	300	550	700	800

Force (N)	Series				
	0K	2K	3K	4K	5K
Fv	14	20	32	65	85
Fd	9	13	25	40	60
Fa	250	400	550	700	800

Notes: the forces were measured on outer shell not fitted with contacts. The mechanical endurance represents the number of cycles after which the latching system is still effective (1 cycle = 1 latching/unlatching – 300 cycles per hour).

Mechanical endurance: 5000 cycles.

The values were measured according to the standard MIL-STD-1344A method 2013.1.

1N = 0.102kg = 0.224 lbs

● General Characteristics

Materials and Surface Treatment

Outer Shell

Brass

In most cases, LEMO connectors have a brass outer shell which is suitable for most general purpose applications, including civilian and military. The brass outer shells have a chrome nickel-plated surface which ensures very good protection against industrial atmosphere, salt air and most corrosive agents.

Alternative protective coatings are available to satisfy other specific environmental conditions:

- electrolytic nickel
- nickel-black chrome. After the black chrome treatment, the part is coated with a protective organic film.

Stainless steel

For applications where there are severe environmental conditions that may rapidly damage the surface finish, we recommend using stainless steel. The AISI 303 stainless steel is a material for general use adapted to most applications requiring a product made entirely of stainless metal.

For the broadcasting industry the heavy duty line with shell in stainless steel offers more resistance to heavy wear conditions.

Aluminum alloy

The aluminum alloy outer shells find numerous applications where light weight is a predominant factor, such as in the aeronautics and space industries, and for portable and mobile equipment.

These materials have high mechanical strength and excellent resistance to corrosion.

The shell surface is protected by anodizing which is available in six colors: blue, yellow, black, red, green, and natural.

Depending on the application, other surface finish is also available (electrolytic nickel-plating, black nickel plating).

Plastic materials

Some connector model shells of the 2B-4B series can be made of plastic. This solution offers optimum electrical insulating properties particularly suitable for medical applications. Grey or white polysulfone (PSU) and beige PEEK offer excellent mechanical properties and is suitable for gas or vapour sterilization.

Some models are also available with an outer shell of cream-colored polyphenylsulfone (PPSU). We recommend this material particularly for applications where products are to withstand hundreds of vapour sterilization cycles.

Other metallic components

In general, most metallic components are manufactured in brass. However, bronze or beryllium copper are used where good elasticity is required (for example: grounding crown). Depending on the application, these parts have electrolytic nickel or nickel-gold plating. These parts can also be manufactured in stainless steel (AISI 416).

Gasket and O-rings

In general, gaskets and O-rings are made of silicone rubber MQ/MVQ. However, for some products they are made of fluorosilicone rubber (FPM).

Materials and Treatments

Component	Material (Standard)	Surface treatment (µm)						Notes	
		chrome			nickel		black chr.		
		Cu	Ni	Cr	Cu	Ni	Ni		Cr
Outer shell, collet nut, conical nut or notched nut	Brass (UNS C 38500)	0.5	3	0.3	0.5	3	1	2	
	Stainless steel (AISI 303 or 304)	without treatment							
	Aluminum alloy (AA 6012)	anodized							
	PEEK, Polyether Etherketone, beige	–						1)	
	PSU (Udel®), Polysulfone, grey or white	–						2)	
	PPSU (Radel®), Polyphenylsulfone, cream	–						2)	
Grounding crown	Bronze (UNS C 54400) or special brass	–	–	–	0.5	3	–	–	
	Stainless steel (AISI 416)	without treatment						3)	
Latch sleeve	Special brass	0.5	3	0.3	0.5	3	–	–	
	Stainless steel (AISI 416)	without treatment						3)	
Locking washer	Bronze (UNS C 52100)	–	–	–	0.5	3	–	–	
Hexagonal or round nut	Brass (UNS C 38500)	–	–	–	0.5	3	–	–	
	Stainless steel (AISI 303 or 304)	without treatment						4)	
	Aluminum alloy (AA 6012)	anodized natural						4)	
Other metallic components	Brass (UNS C 38500)	–	–	–	0.5	3	–	–	
	Stainless steel (AISI 303 or 304)	without treatment							
O-ring and gaskets	Silicone MQ/MVQ or FPM/FKM (Viton®)	–							

Notes:

standards for surface treatment are as follows:

Chrome-plated: FS QQ-C-320B;

Nickel-plated: FS QQ-N-290A, or MIL-C-26074C;

Gold-plated: ISO 4523; and

Black chrome: MIL-C-14538C with a minimum of 10 µm of lacquer protection.

1) for FGG and ENG models of the 3B and 4B series

2) for the FGY and ENY models of the 2B, 3B and 4B series

3) AISI 416 steel is used with shells made of AISI 303 or 304

4) delivered with free and fixed receptacles with aluminum alloy or stainless steel shell

Electrical Characteristics

Shell electrical continuity: (measured according to IEC 60512-2 test 2f)

R₁ Values with grounding crown and latch sleeve or inner-sleeve nickel-plated.

Test current: 1A
 A = Ammeter
 mV = Millivoltmeter
 G = Generator

Keyed series

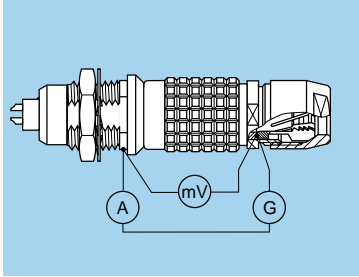

Series	R (mΩ)
2B	2.2
3B	2.2
4B	1.5
5B	1.5
2K	1.8
3K	1.6
4K	1.4
5K	1.4

Electromagnetic compatibility (EMC) and shielding efficiency

The electromagnetic compatibility of a device can only be ensured by meeting a number of basic rules with the design of the device and by carefully selecting components, cables and connectors.

Electrical and electronic devices are to be designed to ensure the following:

- Reduce the emission of generated electromagnetic interference to a level where radios and telecommunication and other devices can properly function;
- Electromagnetic immunity against electromagnetic interference so that they can properly function.

When selecting a connector, screen or shielding efficiency and low resistance to electric continuity between the cable and the connector should be considered.

The design of LEMO connectors with metal shell and grounding crown guarantee optimum shielding efficiency in all applications where electromagnetic compatibility (EMC) is critical.

The performance of a connector is measured through shielding efficiency, a value that represents the ratio between the electromagnetic field on the outside and the inside of the shell. Our measurements are carried out according to the IEC 60169-1-3 standard.

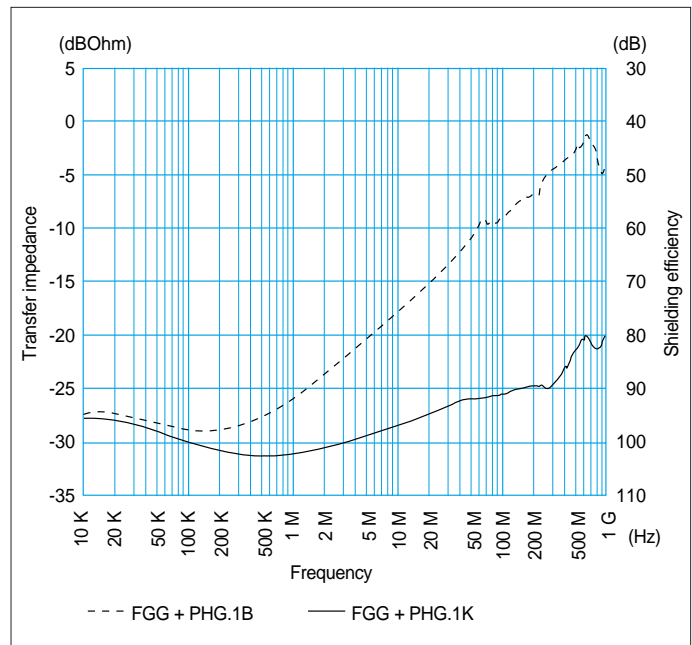

The performance of B series connectors is comparable to the results of measurements carried out on a pair of FGG + PHG.1B connectors.

The performance of K series connectors is comparable to the results of measurements carried out on a pair of FGG + PHG.1K connectors.

Insulator

Plastic material used by LEMO for manufacturing insulators is selected according to the electric and thermal properties required for the various connector types. Characteristics examined for the two connector types are:

- Dielectric strength;
- Comparative tracking index;
- Surface and volume resistivity;
- Continuous service temperature;
- Water absorption;
- Radiation resistance;
- Flammability rating;
- Resistance to hydrocarbon.

Mechanical and Electrical Properties

LEMO uses PEEK (Polyether Etherketone) for the insulator material. The performance of this thermo-plastic material is enhanced by the addition of glass fibers in the resin to achieve very high mechanical strength, to increase dielectric strength and to reduce water absorption rate. The above features of PEEK, plus its excellent chemical and radiation resistance, make it ideal for most applications. Sealing grommets are molded from Viton®. Such polymer has inherently excellent electrical insulating properties which do not change when exposed to adverse environments.

Insulating resistance $>10^{12}\Omega$ (per MIL-STD-1344A method 3003.1).

Technical characteristics

Type	Norme	Units	PEEK	PSU	PPSU	Silicone	FPM
Density	ASTM D 792	–	1.3-1.4	1.24	1.3	~1.2	~1.9
Tensile strength (at 73.4° F)	ASTM D 638/ ISO R527	MPa	92-142	70	70	> 9	> 12
Flexurale strength (at 73.4° F)	ASTM D 790/ ISO R178	MPa	170	106	91	–	–
Dielectric strength	ASTM D 149/IEC 60243	kV/mm	19-25	17-20	15	18-30	–
Volume resis. at 50% HR and 73.4° F	ASTM D 257/IEC 60093	$\Omega \bullet \text{cm}$	10^{16}	5×10^{16}	–	10^{14}	–
Surface resistivity	ASTM D 257	Ω	10^{15}	–	–	–	–
Thermal conductivity	ASTM C 177	W/K \bullet m	0.25	0.26	–	–	–
Comparative tracking index	IEC 60112	V	CTI 150	CTI 150	–	–	–
Maxi. continuous service temperature	UL 746	°F	482	284	356	392	392
Min. continuous service temperature	UL 746	°F	-67	-76	-58	-58	-4
Max. short-time service temperature	–	°F	572	320	392	> 482	572
Water absorption in 24h at 73.4° F	ASTM D 570/ISO R62A	%	0.12	0.3	0.37	–	–
Radiation resistance	–	Gy ¹⁾	10^7	10^5	–	10^5	8×10^4
Flammability rating	ASTM D 635/UL 94	–	V-0/3.2	V-0/4.4	V-0/1.6	–	–
Resistance to steam sterilization	–	–	excel.	good	excel.	good	good

ASTM = American Society for Testing & Materials
 ISO = International Standards Organization
 UL = Underwriters Laboratories
 IEC = International Electrotechnical Commission

Note: ¹⁾ 1 Gy (Gray) = 100 rad

Note: Values of insulation resistance between contacts are given on page 11.

Electrical Contact

Technical Description

The secure reliable electromechanical connection achieved with LEMO female cylindrical contacts is mainly due to two important design features:

1. *Prod proof entry* on the mating side which ensures perfect concentric mating even with carelessly handled connectors; and
2. *The pressure spring*, with good elasticity, maintains a constant even force on the male contact when mated. The leading edge of the pressure spring preserves the surface treatment (gold-plated) and prevents undue wear.

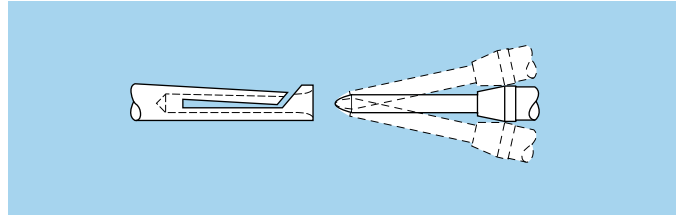

Contact Material and Treatment

LEMO female contacts are made of copper beryllium (QQ-C-530) or bronze (UNS C 54400). These materials are chosen because of their high modulus of elasticity, their excellent electrical conductivity and a high mechanical strength.

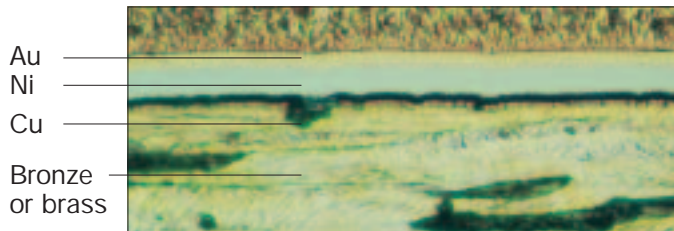

Notes: The standard surface treatment are as follows:
 Nickel: FS QQ-N-290A or MIL-C-26074C; and
 Gold: ISO 4523.

- 1) Minimum value 2) For elbow printed circuit contacts
 3) Treatment completed by 6 µm Sn-Pb tin-plating

LEMO male solder and printed circuit contacts are made of brass (UNS C 38500). Male crimp contacts are made of brass (UNS C 34500) or annealed brass (UNS C 38500) with optimum hardness (HV) for crimping onto the wire.

Type	Material (standard)	Surf. treatment (µm)		
		Cu	Ni	Au ¹⁾
Male crimp	Brass (UNS C 34500)	0.5	3	1.0
	Brass (UNS C 38500)			
Male solder	Brass (UNS C 38500)			
Female crimp	Bronze (UNS C 54400)	0.5	3	1.5
Female solder				
Clips	Cu-Be (FS QQ-C-530)	-	-	-
	Stainless steel			

Notes: The standard surface treatment are as follows:
 Nickel: FS QQ-N-290A or MIL-C-26074C; and Gold: ISO 4523.
 1) Minimum value.

Thickness comparison between the outside and the inside of female contacts

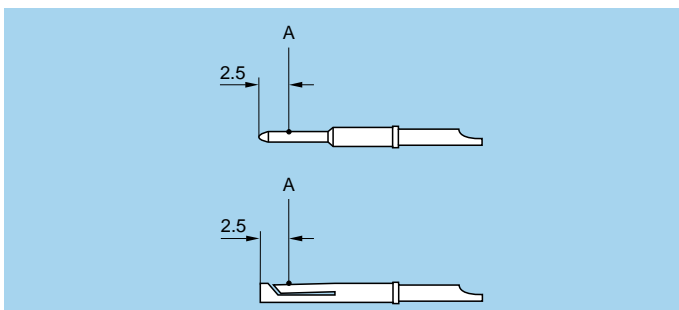

Contact ø A (mm)	Gold thickness		
	male (µm)	female	
		outside (µm)	inside (%)
0.7	1.0	1.5	70
0.9	1.0	1.5	75
1.3	1.0	1.5	75
1.6	1.0	1.5	75
2.0	1.0	1.5	75
4.0	1.0	1.5	75

Note: A = inspection point

Electrical Contact

Contact resistance with relation to the number of mating cycles

Maximum values measured after the mating cycles and the salt spray test according to IEC 60512-6 test 11f.

ø A (mm)	Contact resistance (mΩ)			ø A (mm)	Contact resistance (mΩ)		
	1000 cycles	3000 cycles	5000 cycles		1000 cycles	3000 cycles	5000 cycles
0.7	5.6	5.7	6.1	1.6	2.6	2.7	3.5
0.9	4.1	4.2	4.8	2.0	2.9	3.1	3.3
1.3	2.8	2.9	3.6	4.0	1.6	2.0	2.8

Insulation resistance between the contacts and contact/shell

(measured according to IEC 60512-2 test 3a)

Insulating material	PEEK
new	> 10 ¹² Ω
after humidity test ¹⁾	> 10 ¹⁰ Ω

Note: ¹⁾ 21 days at 95% RH according to IEC 60068-2-3.

Solder contacts

The conductor bucket of these contacts is machined at an angle to form a cup into which the solder can flow.

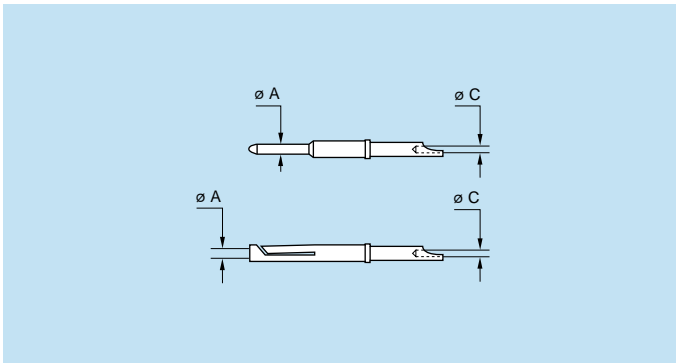

Contact		Conductor			
ø A (mm)	ø C (mm)	Solid		Stranded	
		AWG max.	Section max (mm ²)	AWG max.	Section max (mm ²)
0.7	0.80	22	0.34	22 ¹⁾	0.34
0.9	0.80	22	0.34	22 ¹⁾	0.34
1.3	1.00	20	0.50	20 ¹⁾	0.50
2.0	1.80	14	1.50	16	1.50
4.0	3.70	10	6.00	10	6.00

Note: ¹⁾ For a given AWG, the diameter of some stranded conductor designs is larger than the solder cup diameter. Make sure that the maximum conductor diameter is smaller than ø C.

Crimp contacts

For multipole or hybrid connectors the standard four-identifier crimp method is used (MIL-C-22520F, class I, type 1).

The crimp method requires a controlled compression to obtain a symmetrical deformation of the conductor strand and of the contact material. The radial hole in the side of the contact makes it possible to check whether the conductor is correctly positioned within the contact. A good crimping is characterized by only slightly reduced conductor section and practically no gap.

For optimum crimping, the bronze or brass contacts are annealed to relieve internal stress and reduce material hardening during the crimping process.

Only the crimping zone is annealed with the help of an induction heating machine designed by the LEMO Research and Development Department (microphoto 3).

Crimp contacts are available in standard version (microphoto 1) for mounting maximum size conductors.

For some dimensions, these crimp contacts can be produced with reduced crimp barrels (microphoto 2) for mounting reduced size conductors.



Advantages of crimping

- practical, quick contact fixing outside the insulator
- possible use at high temperature
- no risk of heating the insulator during the conductor-contact fixing
- high tensile strength

The range of cable dimensions that can be crimped into the contacts is indicated on the table on page 12.

Electrical Contact

The crimp contacts are designed to be crimped with the standard four-indent method according to MIL-C-22520F, class 1, type 1.

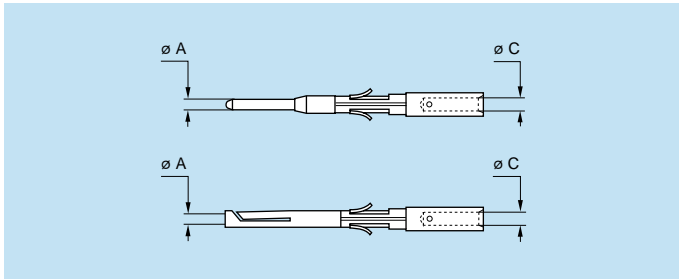

Contact		Conductor stranded				Fr (N)
ø A (mm)	ø C (mm)	AWG stranded		Section (mm ²)		
		min.	max.	min.	max.	
0.7	0.80	26	22 ¹⁾	0.140	0.34	22
0.9	1.10	24	20	0.250	0.50	30
1.3	1.40	20	18	0.500	1.00	40
	1.90 ²⁾	18	14	1.000	1.50	
1.6	1.90	18	14 ¹⁾	1.000	1.50	50
2.0	2.40	16	12 ¹⁾	1.500	2.50	65

Note:

- 1) For a given AWG, the diameter of some stranded conductor designs is larger than the solder cup diameter. Make sure that the maximum conductor diameter is smaller than ø C.
- 2) These contacts are special with an oversized crimp bucket and can be used only with the series 3K.93C.

Note: Fr = mean contact retention force in the insulator (according to IEC 60512-8 test 15a).

Crimp contacts can also be supplied with a reduced crimp barrel. Please consult factory or our Unipole/Multipole catalog.

A detailed range of conductor dimensions that can be crimped into LEMO contacts is given in the table above. See also the section on tooling (pages 97 to 106).

Printed Circuit contacts

Printed circuit contacts are available in straight or elbow versions for certain connector types, mostly for straight and elbow receptacle models. Connection is made on flexible or rigid printed circuits by soldering.

Printed circuit contacts are gold-plated which guarantees optimum soldering, even after long-term storage. However for wave soldering, we recommend removal of the gold-plating from the contact end on the printed circuit side before soldering according to the assembly procedures.

straight

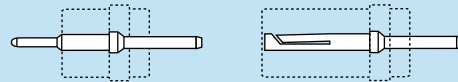

elbow

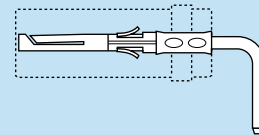

Test Voltage

Test voltage (Ue):
(measured according to the IEC 60512-2 test 4a standard).

It corresponds to 75% of the mean breakdown voltage. Test voltage is applied at 500 V/s and the test duration is one minute.

This test has been carried out with a mated plug and receptacle, with power supply only on the plug end.

Operating voltage (Us):
It is proposed according to the following ratio: $Us = \frac{Ue}{3}$

Caution:

For a number of applications, safety requirements for electrical appliances are more severe with regard to operating voltage.

In such cases operating voltage is defined according to creepage distance and air clearance) between live parts.

Please consult us for the choice of a connector by indicating the safety standard to be met by the product.

Voltage values are given in the table on insulator types for each series corresponding with values measured at sea level and are adapted to all applications up to an altitude of 2000 m.

In case a device is used at a higher altitude, air clearance between live parts has to be multiplied by the following coefficients:
(Test voltage also has to be divided by this coefficient).

altitude (m)	coefficient
2000	1.00
3000	1.14
4000	1.29
5000	1.48

Electrical Contact

Rated Current

(measured according to IEC 60512-3 test 5a).

The specified rated current can be applied simultaneously to all the contacts, corresponding with an average temperature rise of 104° F of the connector.

The current values are indicated in the table of insulator types in each series. For use at higher temperatures, acceptable rated current will be lower. It tends towards zero as the material is used at the maximum operating temperature accepted for the insulator.

In most cases, the current depends on the conductor dimension, or on the printed circuit dimension.

Caution:
In general, connectors should not be unmated while live.

For connectors with PEEK insulator, maximum admissible current will follow the curve below depending on the operating temperature T.

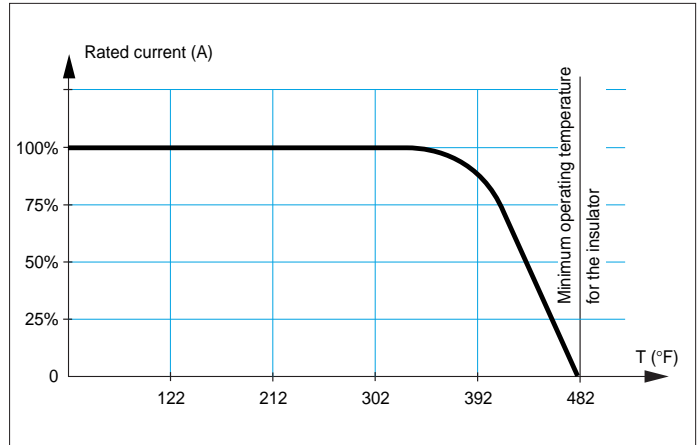

Coaxial contacts

The type C coaxial contact is removable and fixed in place by clips. Cable attachment is made by crimping. The square form is used to captivate center conductor and hexagonal crimping method for the cable shield. A detailed range of coaxial cable that can be installed into our type C coaxial contact is given in the table below.

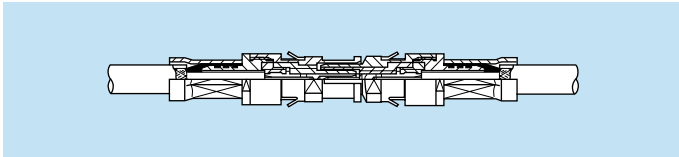

Group	Type
1	RG.174A/U, RG.188A/U, RG.316/U
2	RG.178B/U, RG.196A/U
3	RG.179B/U, RG.187A/U

Coaxial contacts type C

The cable fixing is achieved with hexagonal crimping (MIL-C-22520F, type 2). This method guarantees a good electrical continuity of the shield which improves greatly the shielding efficiency of the cable/connector link. The back end of the crimp nut which receives the shield braid, is milled to ensure a good retention of the shield once crimped.

For the center contact, square form crimp method is used (MIL-C-22520F, type 2). The method requires a controlled compression to obtain a symmetrical deformation of the conductor strand and of the contact

material. The radial hole in the side of the contact enables correct positioning of the conductor within the contact to be verified. A good crimping is characterized by a small conductor section reduction and by the quite closed free spaces.

The LEMO crimp contacts are factory annealed to relieve internal stresses, and reduce the risk of the material work hardening during the crimping process.

Technical characteristics

Characteristics	Unit	Value
Impedance	Ω	50
Operating voltage at 50 Hz	kV rms	0.5
Test voltage at 50 Hz	kV rms	1.6
Rated current	A	2
Insulation resistance	Ω	>10 ¹²
Contact resistance	mΩ	5.8
Shell to shell resistance	mΩ	3.7
VSWR (f=GHz)		1.04 + 0.1f
Max. working frequency	GHz	2.1

Standing wave ratio

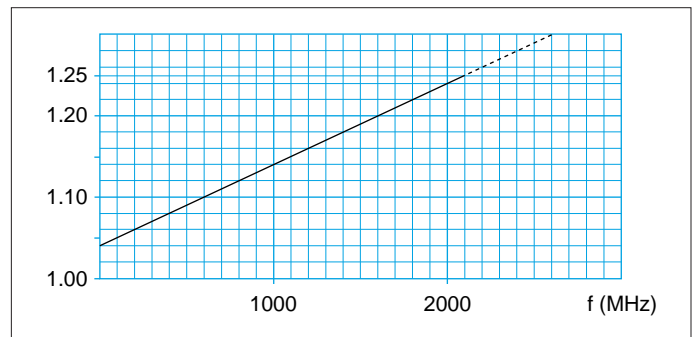

Selection of the LEMO Fiber Optic Contacts





In order to ensure the highest technical performance and to provide the optimum solution for a diversity of applications, LEMO has developed four types of fiber optic contacts; designated **F1**, **F2**, **F3**, and **F4**. These contacts are designed to operate with single fiber, multi fiber, and mixed fiber optical/electrical cable constructions and cater to single and multi-mode fibers from 9/125 to 1500 μm diameter.

The choice of fiber optic contacts depends upon the following criteria:

- Cable construction (single fiber, multi fiber, mixed optical/electrical)
- Fiber type (single-mode or multi-mode).

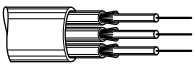
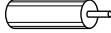
The table below shows the suitability of each contact type with different fibers and cables.

Note that the multi fiber cable can contain many types of optic fibers or a group of fibers and electrical cables leading to mixed optical/electrical connectors.

Contact type	Cable Structure		Fiber Types and dimensions		
	 single fiber	 multi fiber or mixed	 single-mode	multi-mode	
				≤ 100/140μm	≥ 100/140μm
 F1					
 F2					
 F3					
 F4					

See inside back cover for full color diagrams of F1, F2, F3 and F4 contacts

Available series and contact configurations

Single and Multi F.O.

Number of F.O. contacts	Series							
	00	0B	0K	2B-2K	3B-3K	4B-4K	5B-5K	3K.93C
1	●	●	●					
2					●			
4						●		
10							●	
14							●	

Mixed F.O. + L.V.

Number of F.O. contacts	Number of L.V. electrical contacts	Series							
		00	0B	0K	2B-2K	3B-3K	4B-4K	5B-5K	3K.93C
1	2, 4, 6 or 10				●				
1	22					●			
2	4, 6, 10 or 16					●			
2	6, 7, 12, 16 or 18						●		
3	6 or 12						●		
3	10							●	
4	5 or 9						●		
9	3							●	

Mixed F.O. + L.V. + H.V.

Number of F.O. contacts	Number of L.V. electrical contacts	Number of H.V. electrical contacts	Series							
			00	0B	0K	2B-2K	3B-3K	4B-4K	5B-5K	3K.93C
2	2	2								●
6	2	4							●	
12	1	2							●	

Mixed F.O. + L.V. + Coax

Number of F.O. contacts	Number of L.V. electrical contacts	Number of coax electrical contacts	Series							
			00	0B	0K	2B-2K	3B-3K	4B-4K	5B-5K	3K.93C
1	6	1					●			
1	16	1					●			
2	–	2						●		
2	6	1						●		

Optical Performance for F1, F2, F3, and F4 Type Contacts

The optical performance for the fiber optic contacts relates to the insertion and return losses measured at the junction of the fiber to fiber interface. These losses are caused mainly by minute geometrical effects of the critical alignment components and deviations in the fiber core and cladding dimensions.

The insertion loss results for multi-mode and single-mode fibers are given whereas the return loss values are provided for single-mode fibers only.

Insertion and return losses are expressed in decibels (dB). The data shown in the diagrams below correspond to numerous matings using various batches of optical fibers and connectors.

Measurements with Single-mode Fiber for F2 and F4 Contacts.

Insertion loss

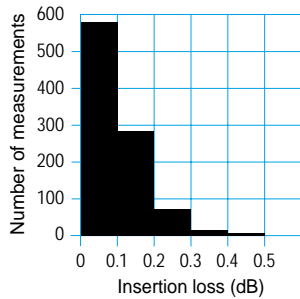

Mean = 0.10 dB
 Tested at 1300 nm
 Tested according to the standard IEC 61300-03-04,
 Insertion Method B.
 Fiber = 9/125 μm
 Ferrule bore diameter = 125 μm

Return loss

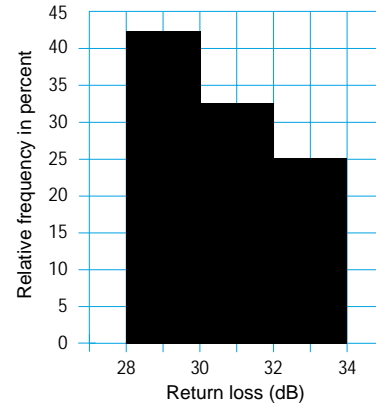

Mean = 30.42 dB
 Tested at 1300 nm
 Tested according to the standard IEC 61300-03-06,
 Branching Device Method
 Fiber = 9/125 μm, Hand Polishing

Note: It is possible to obtain return losses better than 45 dB with UPC polishing techniques. Please consult LEMO for more detailed information.

Measurements with Multi-mode Fiber for F2 and F4 Contacts

Insertion loss

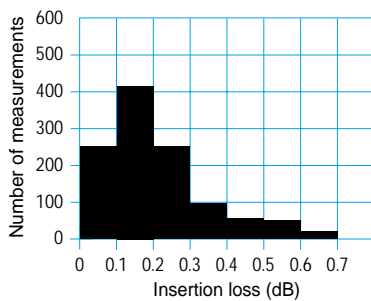

Mean = 0.25 dB
 Tested at 1300 nm
 Tested according to the standard IEC 61300-03-04,
 Insertion Method B.
 Fiber = 50/125 μm
 Ferrule bore diameter = 126 μm

Measurements with Multi-mode Fiber for F1 and F3 Contacts

Insertion loss

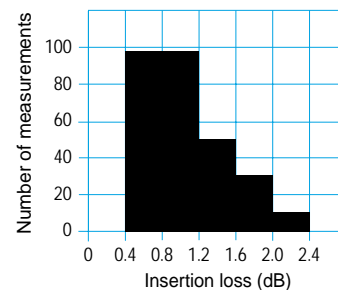

Mean = 1.13 dB
 Tested at 850 nm
 Tested according to the standard IEC 61300-03-04,
 Insertion Method B.
 Fiber = 200/230 μm
 Ferrule bore diameter = 235 μm

Change in attenuation vs. environmental and mechanical conditions

Characteristic	Value	Standard	Change in attenuation ¹⁾	
			F2-F4 Contacts	F1-F3 Contacts
High temperature	+ 176 °F	IEC 61300-02-18	< 0.20 dB	< 0.20 dB
Low temperature	- 40 °F	IEC 61300-02-17	< 0.20 dB	< 0.20 dB
Change of temperature (7 cycles)	Diagram 1 below	IEC 61300-02-22	< 0.20 dB	< 0.20 dB
Damp heat steady state	Up to 95 % RH, 140 °F	IEC 61300-02-19	< 0.20 dB	< 0.15 dB
Mating cycles (contact F1; F2; F3)	1000	IEC 61300-02-02	< 0.15 dB	< 0.15 dB
Mating cycles (contact F4)	500	IEC 61300-02-02	< 0.15 dB	–
Cable retention ²⁾	100 N	IEC 61300-02-04	< 0.10 dB	–
Impact (Method A)	1 m onto concrete floor	IEC 61300-02-12	< 0.10 dB	< 0.15 dB
Shock (3 cycles in 2 directions)	100 g, 10-50 ms; 20 g, 6-9 ms	IEC 61300-02-09	< 0.10 dB	< 0.20 dB
Vibration (7 cycles)	Diagram 2 below	IEC 61300-02-01	< 0.20 dB	< 0.25 dB

Note:
¹⁾ The insertion loss variations were measured during the entire environmental and mechanical tests respectively.
²⁾ Value quoted is for 2.5 mm tight jacket cable. In practice the cable retention depends on many factors including the cable construction.

Diagram 1: Temperature cycles

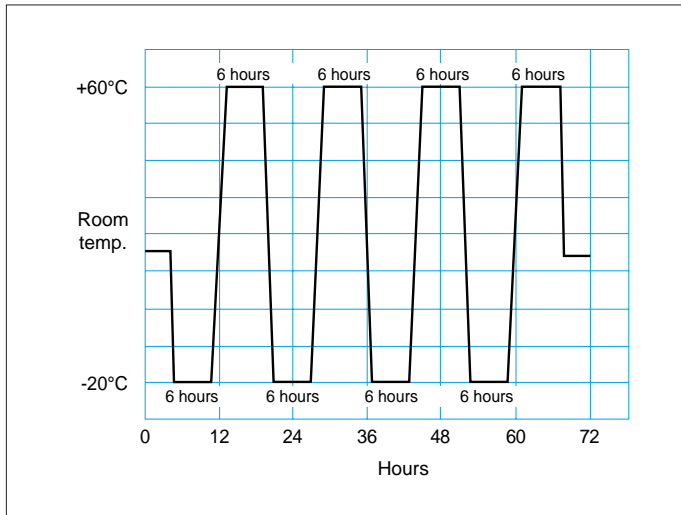
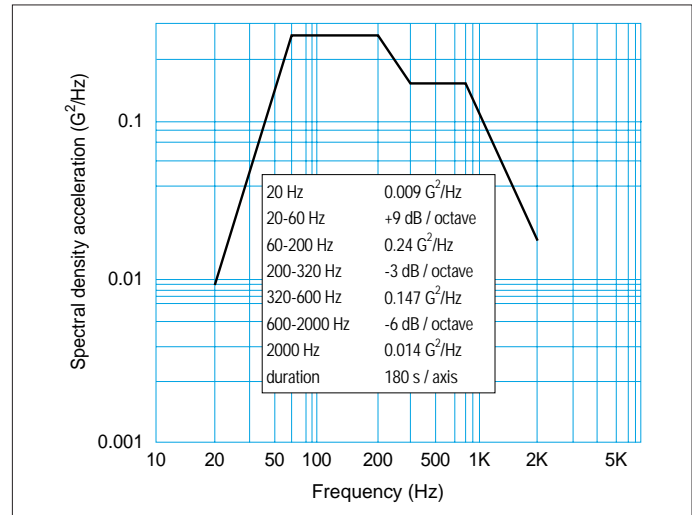
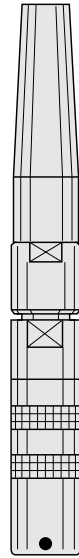
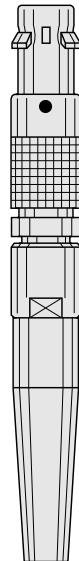

Diagram 2: Vibration





- 00 Series Connectors



● 00 Series Connectors

The 00 series connectors are fitted with LEMO **F4** type fiber optic contacts.

The main features of this series are as follows:

- Security of the LEMO self-latching Quick-Lok™ system
- Minimum mounting space requirement (high packing density)
- Protection against accidental contamination or damage to the fiber end face because the ferrules do not protrude outside of the connector shell
- The alignment key (G, B) ensures excellent repeatability of performance during frequent matings
- Assembly of the fiber optic contact uses a ceramic ferrule with spherical end face
- Simple and fast polishing ensuring the physical contact of the fiber end face
- The alignment tube can be easily removed in order to clean the fiber end face.

00 Series consists of nine connector models.

The active device housings are designed to accept emitting or receiving components such as LEDs or photodiodes in a TO-18 case.

The plugs and receptacles are suitable for use with single fiber cables fitted with single-mode or multi-mode fibers of the following dimensions; 9/125, 50/125, 62.5/125, 100/125 and 100/140 µm.

Interconnections

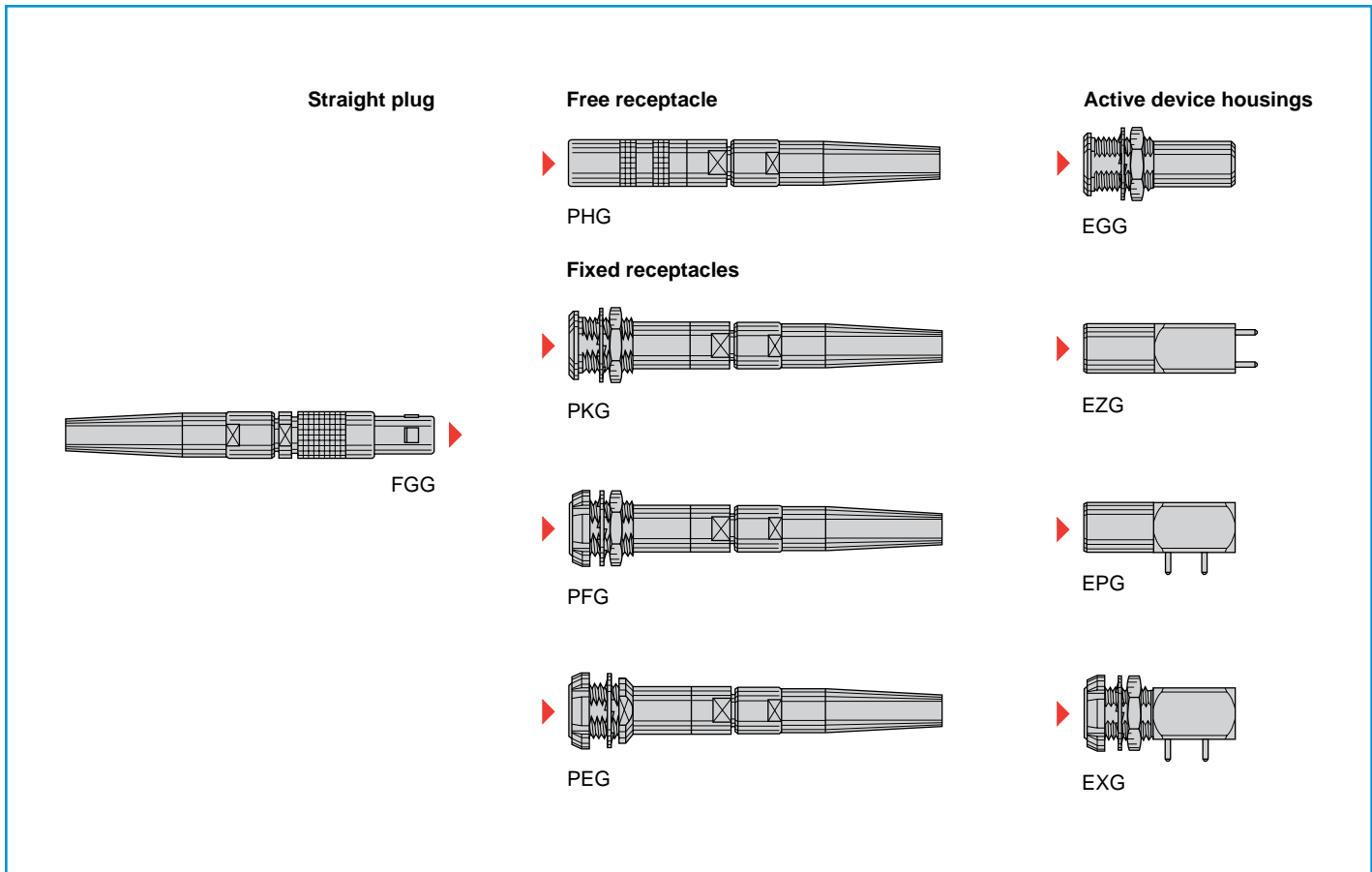

Model Description

EGG Fixed active device housing, nut fixing, key (G) or key (B)

EPG Elbow active device housing (90°) for printed circuit, key (G) or key (B)

EXG Elbow active device housing (90°) for printed circuit, with two nuts, key (G) or key (B), (back panel mounting)

EZG Straight active device housing for printed circuit, key (G) or key (B)

FGG Straight plug, key (G) or key (B), with bend relief

PEG Fixed receptacle, nut fixing, key (G) or key (B), with bend relief, (back panel mounting)

PFG Fixed receptacle, with two nuts, key (G) or key (B), with bend relief, (back panel mounting)

PHG Free receptacle, key (G)

or key (B), with bend relief

PKG Fixed receptacle, nut fixing, key (G) or key (B), with bend relief

Part Section Showing Internal Components

Connector

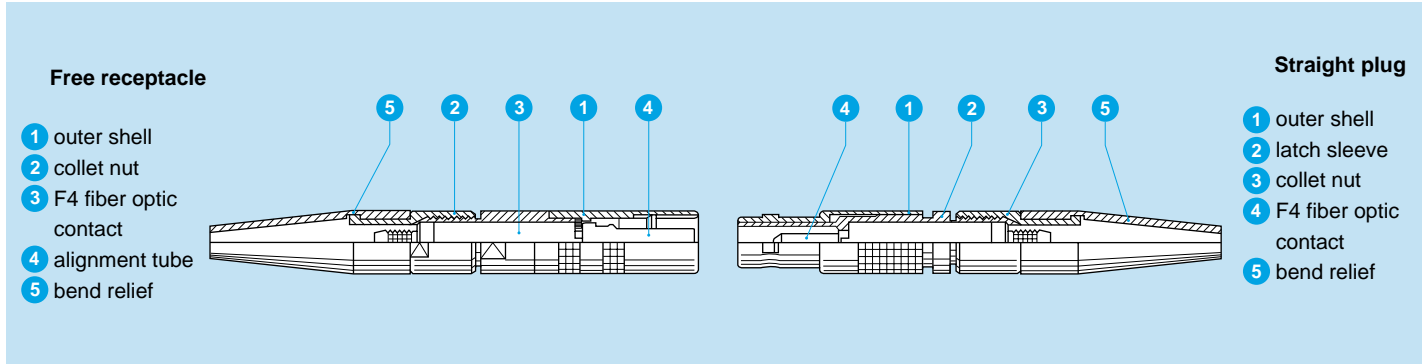

F4 Contact

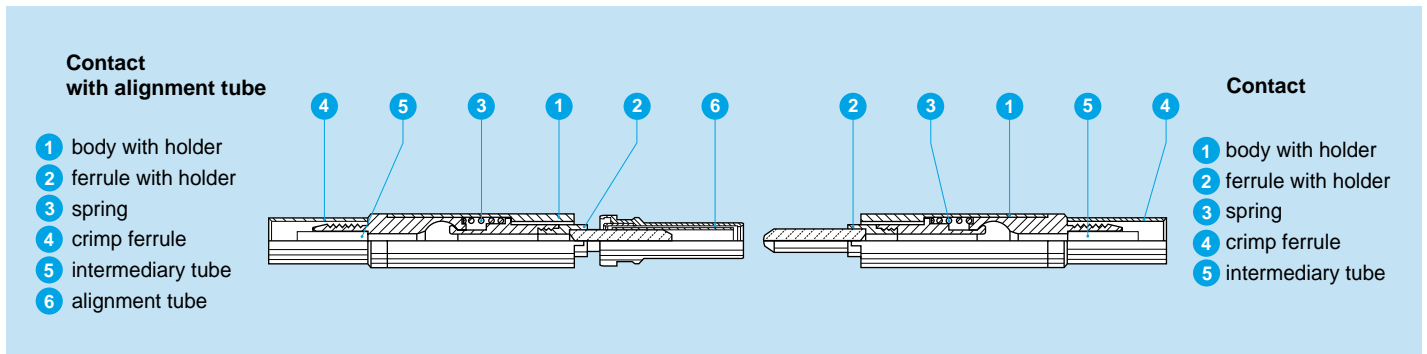

Technical Characteristics

Mechanical and Climatic

Characteristics	Value	Standard
Endurance	> 5000 cycles	IEC 61300-02-02
Humidity	up to 95 % at 140°F	IEC 61300-02-19
High temperature ^{1) 2)}	+176° F	IEC 61300-02-18
Low temperature	-40° F	IEC 61300-02-17
Protection index (mated)	IP 50	IEC 60529
Cable retention	100 N	IEC 61300-02-04

Optical

Characteristic	Value	Standard	Method
Average insertion loss fiber 9/125 μm	0.10 dB	IEC 61300-03-04	Insertion Method B
Average insertion loss fiber 50/125 μm	0.25 dB	IEC 61300-03-04	Insertion Method B
Return loss fiber 9/125 μm (UPC)	≥45 dB	IEC 61300-03-06	Branching Device Met.
Return loss fiber 9/125 μm (Hand polish)	~30 dB	IEC 61300-03-06	Branching Device Met.

Alignment Key and Polarized Keying Systems

Model	No of keys	Angle		Note
		α		
●●G	1	0°	■	
●●B	2	60°	□	

■ First choice alternative □ Special order alternative

Note: Detailed characteristics are presented on inside back cover and pages 15-16.

Part Number Example

A different part number is applicable for each of the following product type:

- Plugs or receptacles for assembly onto cables
- Active device housings

Straight plug with bend relief

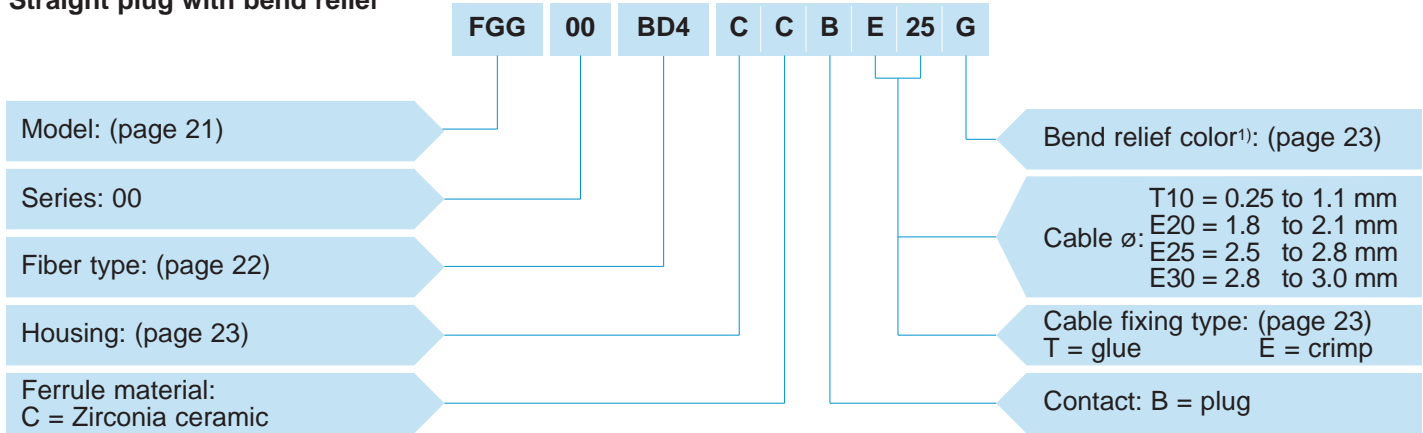

FGG.00.BD4.CCBE25G = Straight plug with key (G), 00 series for single-mode or multi-mode fibers, F4 fiber optic contact, ferrule hole diameter 128 µm, chrome-plated brass housing, zirconia ceramic ferrule, plug type contact, crimp type cable fixing for 2.5 to 2.8 mm diameter cable, and gray bend relief.

Note: ¹⁾ The bend relief sleeve is necessary to the proper function of the connector thus the connector can only be ordered with the appropriate sleeve.

Free receptacle with bend relief

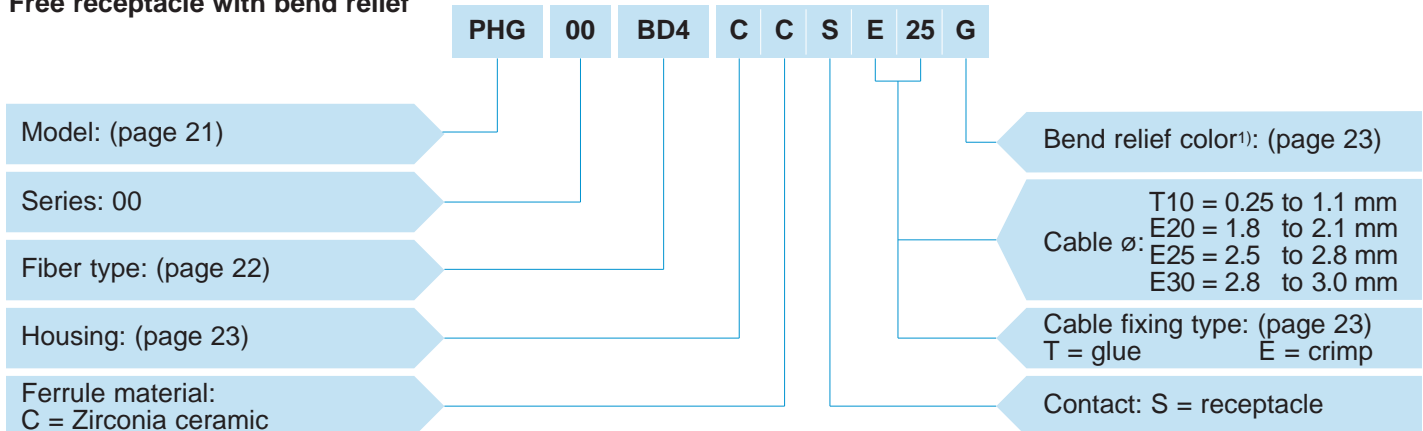

PHG.00.BD4.CCSE25G = Free receptacle with key (G), 00 series for single-mode or multi-mode fibers, F4 fiber optic contact, ferrule hole diameter 128 µm, chrome-plated brass housing, zirconia ceramic ferrule, receptacle type contact, crimp type cable fixing for 2.5 to 2.8 mm diameter cable, and gray bend relief.

Note: ¹⁾ The bend relief sleeve is necessary to the proper function of the connector thus the connector can only be ordered with the appropriate sleeve.

Active device housing

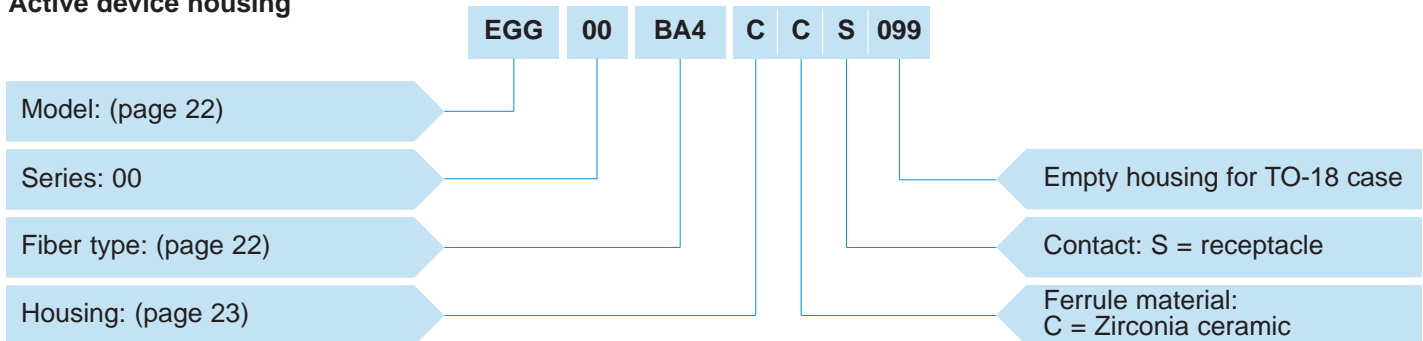

EGG.00.BA4.CCS099 = Straight active device housing, nut fixing with key (G), 00 series, with ferrule for F4 fiber optic contact, assembled with single-mode fiber ø 9/125, chrome-plated brass housing, zirconia ceramic ferrule, receptacle contact, empty housing for TO-18 case.

● Models

FGG.00 Straight plug, key (G) or key (B), with bend relief

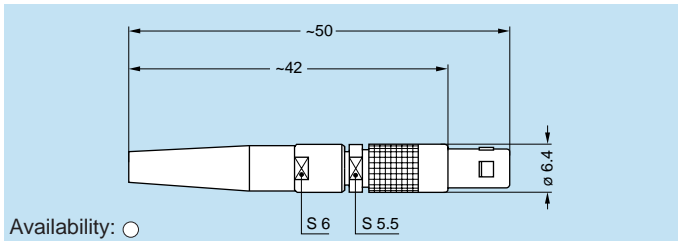

Availability: ○

PHG.00 Free receptacle, key (G) or key (B), with bend relief

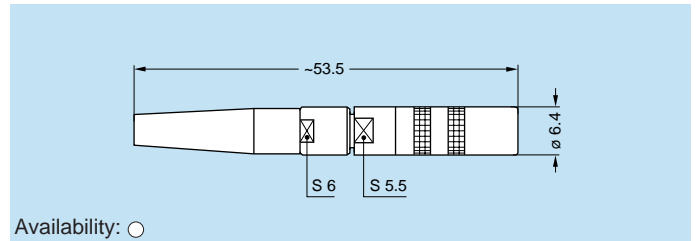
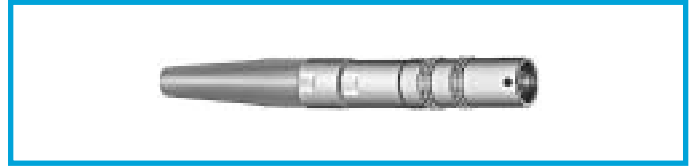

Availability: ○

PKG.00 Fixed receptacle, nut fixing, key (G) or key (B), with bend relief

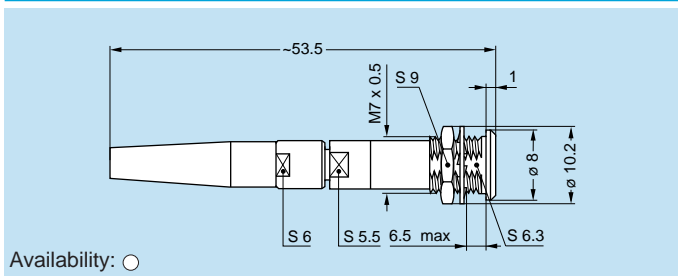

Availability: ○

Panel cut-out (page 23)

PEG.00 Fixed receptacle, nut fixing, key (G) or key (B), with bend relief (back panel mounting)

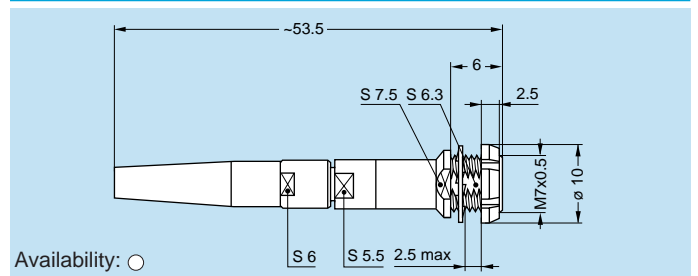

Availability: ○

Panel cut-out (page 23)

PFG.00 Fixed receptacle, with two nuts, key (G) or key (B), with bend relief (back panel mounting)

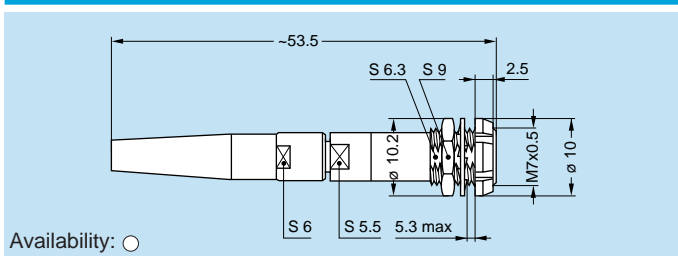

Availability: ○

EGG.00 Fixed active device housing, nut fixing, key (G) or key (B)

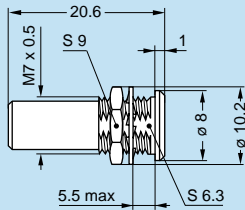
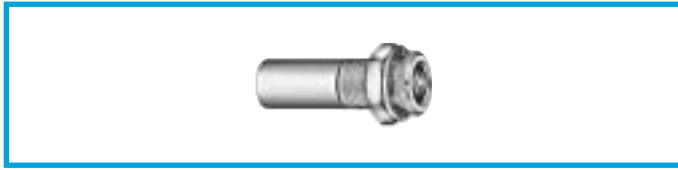

Availability: ○

Panel cut-out (page 23)

EZG.00 Straight active device housing for printed circuit, key (G) or key (B)

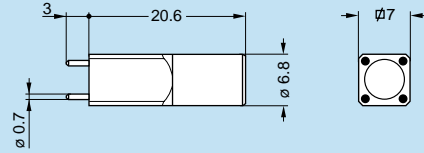

Availability: ○

Panel cut-out (page 23)

PCB drilling pattern (page 23)

EPG.00 Elbow active device housing (90°) for printed circuit, key (G) or key (B)

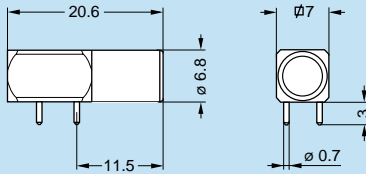
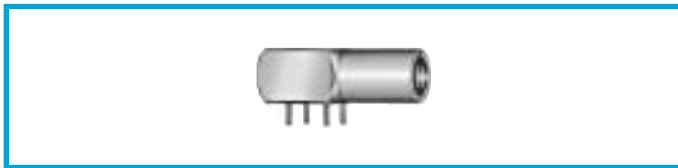

Availability: ○

Panel cut-out (page 23)

PCB drilling pattern (page 23)

EXG.00 Elbow active device housing (90°) for printed circuit, with two nuts, key (G) or key (B), (back panel mounting)

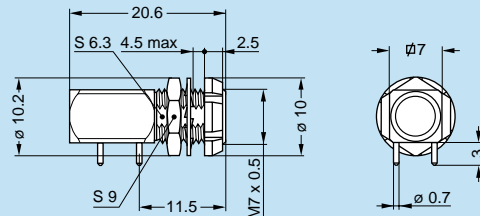
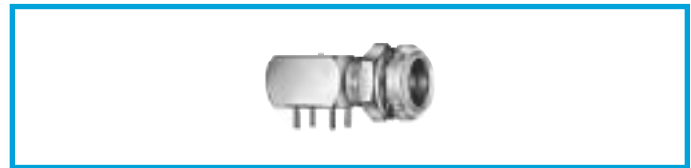

Availability: ○

Panel cut-out (page 23)

PCB drilling pattern (page 23)

Note: Upon request active device housing can be delivered with a specific device of your choice already fitted into. Please consult the factory.

● Fiber Type

The choice of the ferrule hole diameter is dependent upon the fiber core/cladding size. LEMO offers a range of ferrule hole diameters to suit the users' specific requirements.

Plug or receptacles

The type reference represents the ferrule hole diameter.

Reference	ø Core/Cladding (µm)	Ferrule hole diameter (µm)	Note 1)
BA4	9/125	125	■
BB4	50/125	126	■
BC4	62.5/125	127	□
BD4	100/125	128	□
FA4	100/140	140	□
FB4		144	■

Note: 1) The BA4 type (ferrule hole 125 µm) is recommended for single-mode fibers. The BB4 type (ferrule hole 126 µm) is commonly used with multi-mode fibers.

Active device housings

The type reference represents the type of fiber used.

Reference	ø Core/Cladding (µm)	Note
BA4	9/125	■
CA4	50/125	□
DA4	62.5/125	■
EA4	100/125	□
FA4	100/140	■

■ First choice alternative □ Special order alternative

● Standard, typically 0-6 weeks delivery for quantities of 250 or less.

○ Non-standard product, contact LEMO USA, typically 6-12 weeks delivery for quantities of 250 or less.

Non-standard product is defined as any product which contains one or more components which are not standard.

● Housing

Ref.	Material	Surface treatment		Note
		Outer shell and collet nut	Latch sleeve and grounding crown	
C	Brass	chrome	nickel	■
N	Brass	nickel	nickel	□
K	Brass	black chrome	nickel	□
T	Stainless steel	without treatment	stainless steel	□

■ First choice alternative □ Special order alternative

● Cable Fixing Type

Reference		Cable structure	Cable ø (mm)
Cable fixing Type	Reference ø (mm)		
T	10	Buffer coated fiber	0.25 to 1.1
E	20	Tight jacket cable	1.8 to 2.1
E	25		2.5 to 2.8
E	30		2.8 to 3.0

● Bend Relief

Models FGG, PHG, PKG, PEG and PFG are supplied with a bend relief. The reference for the color of the bend relief is chosen from the table below and it should be stated in the «bend relief» position of the connector part number.

Ref.	Color
A	blue
B	white

Ref.	Color
G	grey
J	yellow

Ref.	Color
M	brown
N	black

Ref.	Color
R	red
S	orange

Ref.	Color
V	green

● Tooling

The full range of tools for terminating fiber optic F4 contacts for this 00 series is shown on pages 103 to 106. Consult the factory for the termination instructions.

● Panel Cut-Outs

Panel cut-outs

PKG-PEG-PFG
EGG-EXG

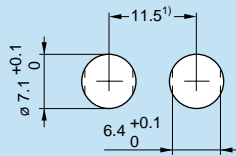

PCB drilling pattern, for the fixing pins

EZG-EPG-EXG

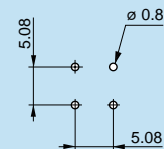

Note: 1) Minimum distance between two neighboring components.
Mounting nut torque: **1 Nm**. The value shown above is the maximum torque for each connector type.
1N = 0.102 Kg

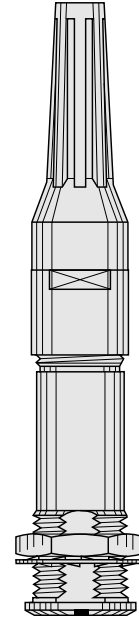

- **0B Series Connectors**

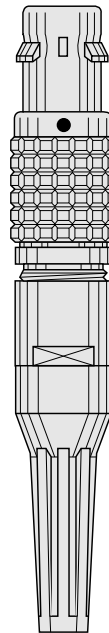

● 0B Series Connectors

The 0B series connectors are fitted with the LEMO **F3** type fiber optic contacts.

The main features of this series are as follows:

- Security of the LEMO self-latching Quick-Lok™ system
- Minimum mounting space requirement (high packing density)
- Protection against accidental contamination or damage to the fiber end face because the ferrules do not protrude outside the connector shell
- The alignment key (G, A...F) ensures excellent repeatability of performance during frequent matings
- Simple and proven construction of the fiber optic contact with a ceramic or metallic ferrule
- Polishing with special tooling ensuring a minimum spacing of fibers which are not in physical contact.

0B series consists of six connector models.

The active device housings are designed to accept emitting or receiving components such as LEDs or photodiodes in a TO-18 case (without plastic can).

The plugs and straight receptacles are suitable for use with single fiber cables fitted with Si/Si or plastic multi-mode fibers with dimensions ranging from 100/140 to 1500 µm external diameter.

Interconnections

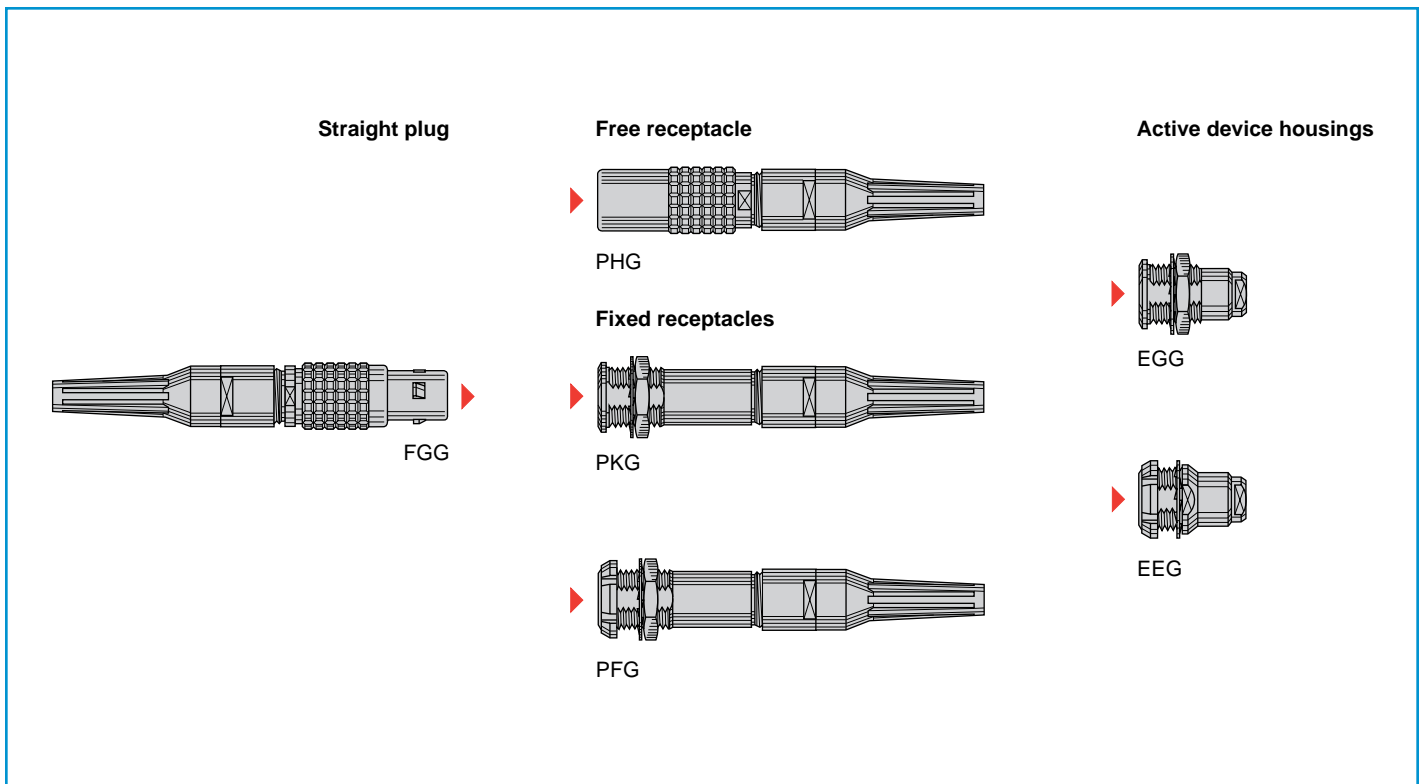

Model Description

- EEG** Fixed active device housing, nut fixing, key (G) or keys (A...F), (back panel mounting)
- EGG** Fixed active device housing, nut fixing, key (G) or keys (A...F)

- FGG** Straight plug, key (G) or keys (A...F), with bend relief
- PFG** Fixed receptacle, with two nuts, key (G) or keys (A...F), with bend relief, (back panel mounting)

- PHG** Free receptacle, key (G) or keys (A...F), with bend relief
- PKG** Fixed receptacle, nut fixing, key (G) or keys (A...F), with bend relief

Part Section Showing Internal Components Connector

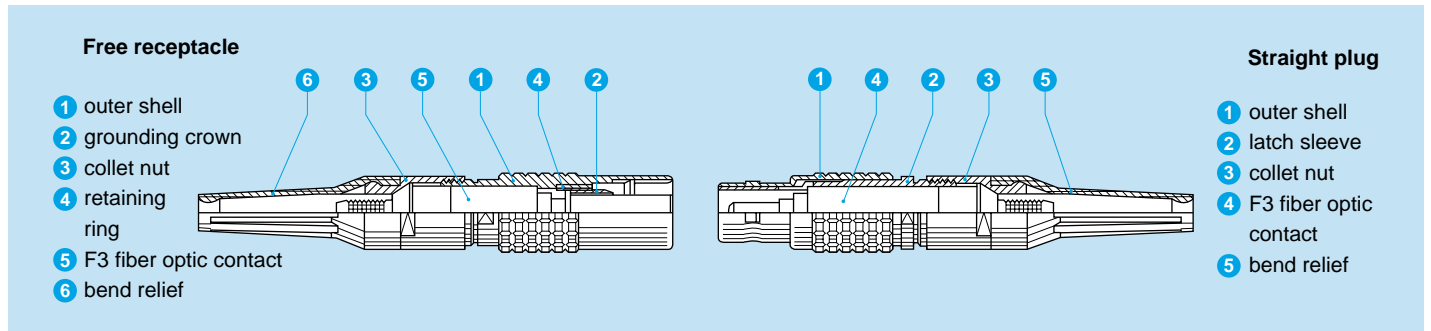

F3 Contact

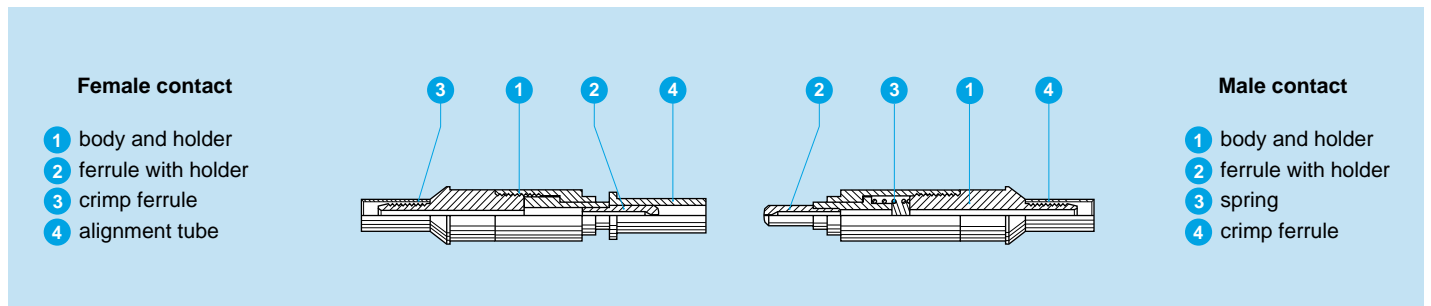

Technical Characteristics

Mechanical and Environmental

Characteristic	Value	Standard
Endurance	1000 to 5000 cycles	IEC 61300-02-02
Humidity	up to 95 % at 140°F	IEC 61300-02-19
High temperature	+176°F	IEC 61300-02-18
Low temperature	-40°F	IEC 61300-02-17
Protection index (mated)	IP 50	IEC 60529
Cable retention	100 N	IEC 61300-02-04

Optical

Characteristic	Value	Standard	Method
Average insertion loss fiber 200/230 μm	1.13 dB	IEC 61300-03-04	Insertion Method B

Note: Detailed characteristics are presented on inside back cover and pages 15-16.

Alignment Key and Polarized Keying Systems

Front view of a receptacle

Model	No of keys	Angles	Note
●●G	1	α	0° ■
●●A	2		30° ■
●●B	2		60° ■
●●C	2		90° ■
●●D	2	β	135° □
●●E	2		145° □
●●F	2		155° □

■ First choice alternative □ Special order alternative

● Part Number Example

Straight plug with bend relief

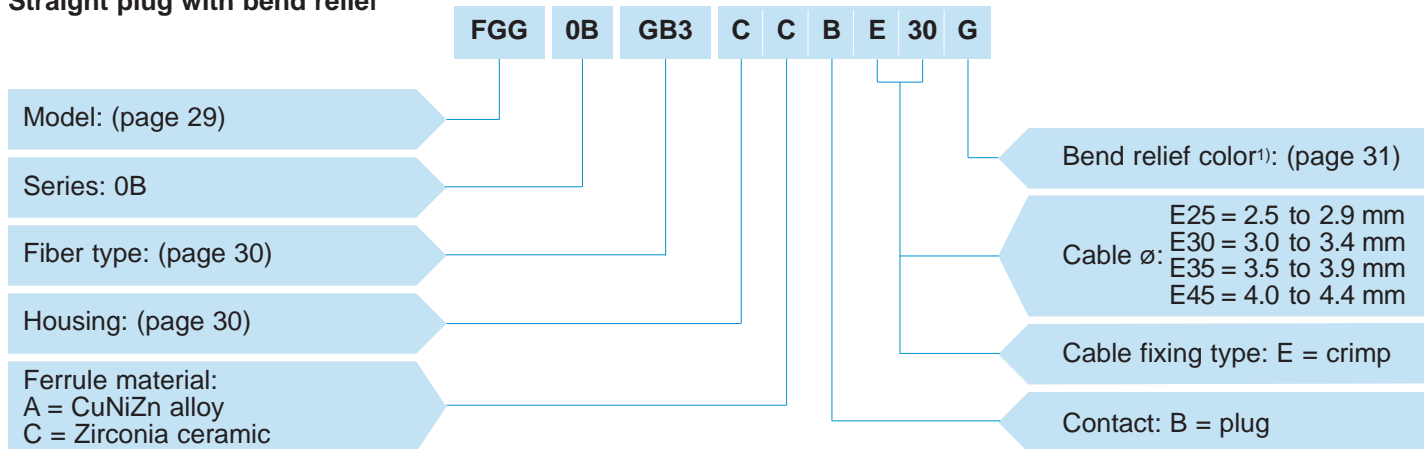

FGG.0B.GB3.CCBE30G = Straight plug with key (G), 0B series, F3 fiber optic contact, ferrule hole diameter 235 µm, chrome-plated brass housing, zirconia ceramic ferrule, plug type contact, crimp type cable fixing for 3.0 to 3.4 mm diameter cable, and gray bend relief.

Note: ¹⁾ The bend relief sleeve is necessary to the proper function of the connector thus the connector can only be ordered with the appropriate sleeve.

Free receptacle with bend relief

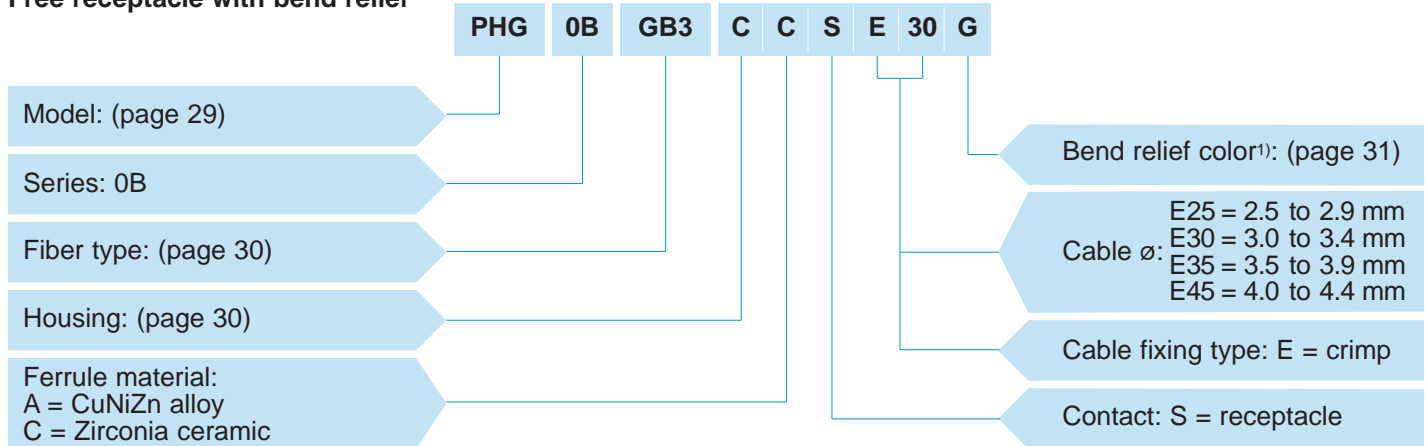

PHG.0B.GB3.CCSE30G = Free receptacle with key (G), 0B series, F3 fiber optic contact, ferrule hole diameter 235 µm, chrome-plated brass housing, zirconia ceramic ferrule, receptacle type contact, crimp type cable fixing for 3.0 to 3.4 mm diameter cable, and gray bend relief.

Note: ¹⁾ The bend relief sleeve is necessary to the proper function of the connector thus the connector can only be ordered with the appropriate sleeve.

Active device housings

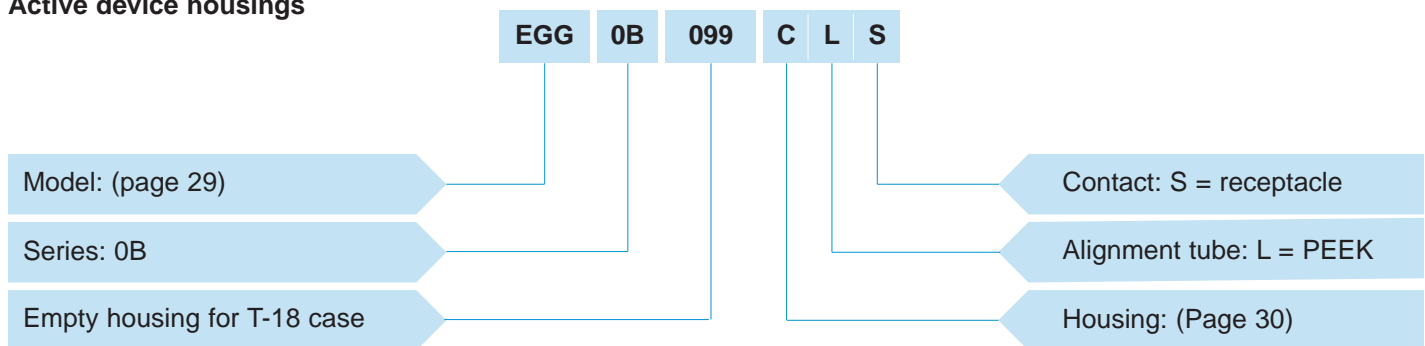

EGG.0B.099.CLS = Fixed active device housing, nut fixing, with key (G), 0B series, empty housing for TO-18 case, chrome-plated brass housing, PEEK alignment tube, receptacle contact.

• Models

FGG.0B Straight plug, key (G) or keys (A...F), with bend relief

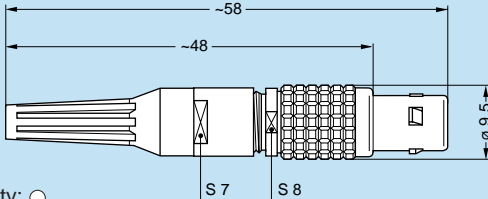

Availability: ○

PHG.0B Free receptacle, key (G) or keys (A...F), with bend relief

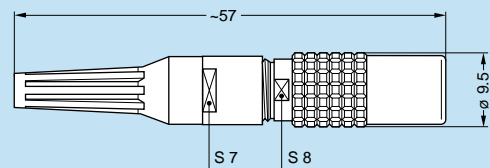

Availability: ○

PKG.0B Fixed receptacle, nut fixing, key (G) or keys (A...F), with bend relief

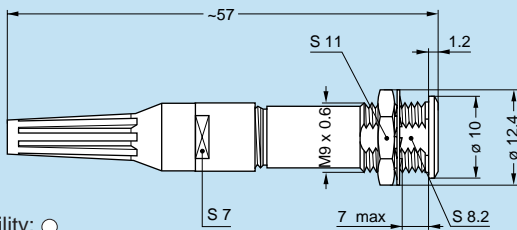
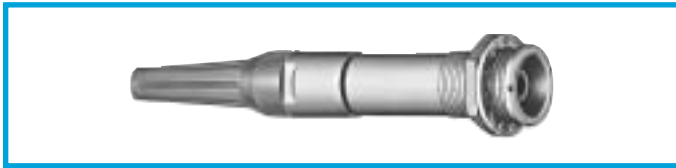

Availability: ○

Panel cut-out (page 31)

PFG.0B Fixed receptacle, with two nuts, key (G) or keys (A...F), with bend relief, (back panel mounting)

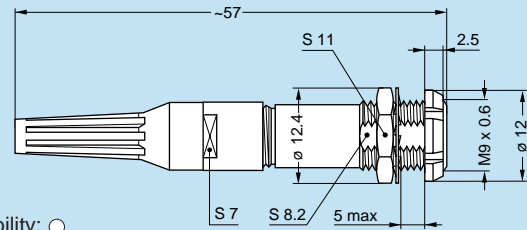
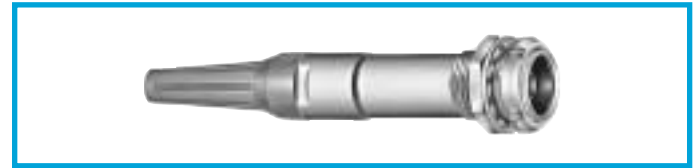

Availability: ○

Panel cut-out (page 31)

Note: The overall length dimension is with Desmopan bend relief (see pages 91 and 92).

EGG.0B Fixed active device housing, nut fixing, key (G) or keys (A...F)

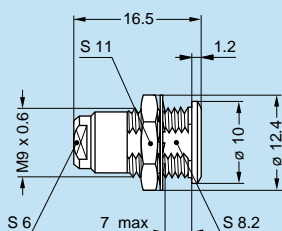

Availability: ○

Panel cut-out (page 31)

EEG.0B Fixed active device housing, nut fixing, key (G) or keys (A...F), (back panel mounting)

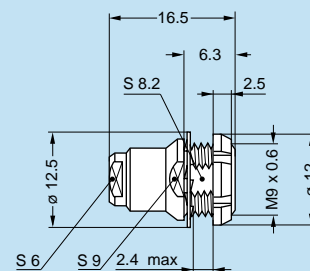

Availability: ○

Panel cut-out (page 31)

● Standard, typically 0-6 weeks delivery for quantities of 250 or less.
○ Non-standard product, contact LEMO USA, typically 6-12 weeks delivery for quantities of 250 or less.
Non-standard product is defined as any product which contains one or more components which are not standard.

● Fiber Type

The choice of the ferrule hole diameter is dependent upon the fiber cladding size. LEMO offers a range of ferrule hole diameters to suit the users' specific requirements.

Reference	Core/cladding ø (µm)	Ferrule hole ø (µm)	Ferrule material	Material ref.	Fiber type	Note
FB3	100/140	144	Ceramic	C	Silica	■
GA3	200/230	230	Ceramic	C	HCS	□
GB3	200/230	235	Ceramic	C	HCS	■
HA3	300/330	330	Ceramic	C	HCS	□
HB3	300/330	335	Ceramic	C	HCS	■
JA3	400/430	430	Metal	A	HCS	□
JB3	400/430	435	Metal	A	HCS	■
KA3	600/630	630	Metal	A	HCS	□
KB3	600/630	640	Metal	A	HCS	■
LA3	800/830	830	Metal	A	HCS	□
LB3	800/830	845	Metal	A	HCS	■
MA3	1000/1035	1035	Metal	A	HCS	□
MB3	1000/1035	1050	Metal	A	HCS	■
NA3	500	500	Metal	A	Polymer	□
NB3	500	550	Metal	A	Polymer	■
PA3	750	750	Metal	A	Polymer	□
PB3	750	825	Metal	A	Polymer	■
RA3	1000	1000	Metal	A	Polymer	□
RB3	1000	1100	Metal	A	Polymer	■
RK3	1400	1430	Metal	A	Polymer	■
SA3	1500	1500	Metal	A	Polymer	□
SB3	1500	1650	Metal	A	Polymer	■
TA3	200/380	380	Metal	A	PCS	□
TB3	200/380	410	Metal	A	PCS	■
VA3	300/440	440	Metal	A	PCS	□
VB3	300/440	475	Metal	A	PCS	■
WA3	600/750	750	Metal	A	PCS	■
WB3	600/750	810	Metal	A	PCS	■

■ First choice alternative
□ Special order alternative

● Housing

Ref.	Material	Surface treatment		Note
		Outer shell and collet nut	Latching sleeve and grounding crown	
C	Brass	chrome	nickel	■
N	Brass	nickel	nickel	□
K	Brass	black chrome	nickel	□
T	Stainless steel	without treatment	stainless steel	□

■ First choice alternative □ Special order alternative

● Bend Relief

Models FGG, PHG, PKG and PFG are supplied with a bend relief. The reference for the color of the bend relief is chosen from the table below and it should be stated in the «bend relief» position of the connector part number.

Ref.	Color
A	blue
B	white

Ref.	Color
G	grey
J	yellow

Ref.	Color
M	brown
N	black

Ref.	Color
R	red
S	orange

Ref.	Color
V	green

● Tooling

The full range of tools for terminating fiber optic F3 contacts of this 0B series is shown on pages 103 to 106. Consult the factory for the termination instructions.

● Panel Cut-Outs

Panel cut-outs

PKG-PFG-EGG-EEG

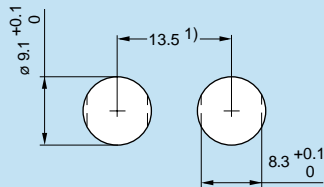

Note: ¹⁾ Minimum distance between two neighboring components.
 Mounting nut torque: **2.5 Nm**. 1N = 0.102 Kg
 The value shown above is the maximum torque for each connector type.

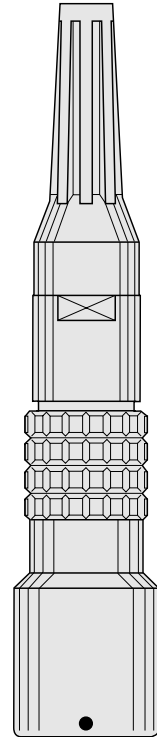

- **OK Series Connectors**

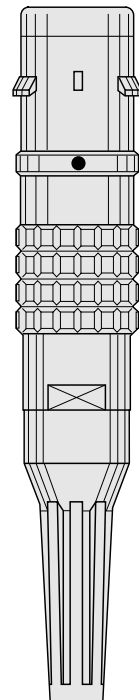

● OK Series Connectors

The LEMO OK series fiber optic connector is ideal for use in harsh environments. The mated connectors are sealed to IP 66-IP 68 (underwater immersion to 1.5 m depth). It uses the standard LEMO **F2** fiber optic contact which has undergone extensive mechanical, optical and environmental testing and has seen service in many critical applications such as outside broadcast television.

Based upon the proven LEMO self-latching Quick-Lok™ system, this new fiber optic connector features:

- Sealed to IP 66-IP 68 for environmental protection
- Highly compact design for space saving
- Very low insertion loss for both multi-mode and single-mode fibers
- Low back reflection performance
- The alignment key (G, A...F) ensures excellent repeatability of performance during frequent matings
- Fully floating ceramic ferrule with spherical end face
- Simple and fast polishing ensuring the physical contact of the fiber end face
- The alignment tube can be easily removed in order to clean the fiber end face
- Field termination possible
- Excellent shock and vibration resistance.

Interconnections

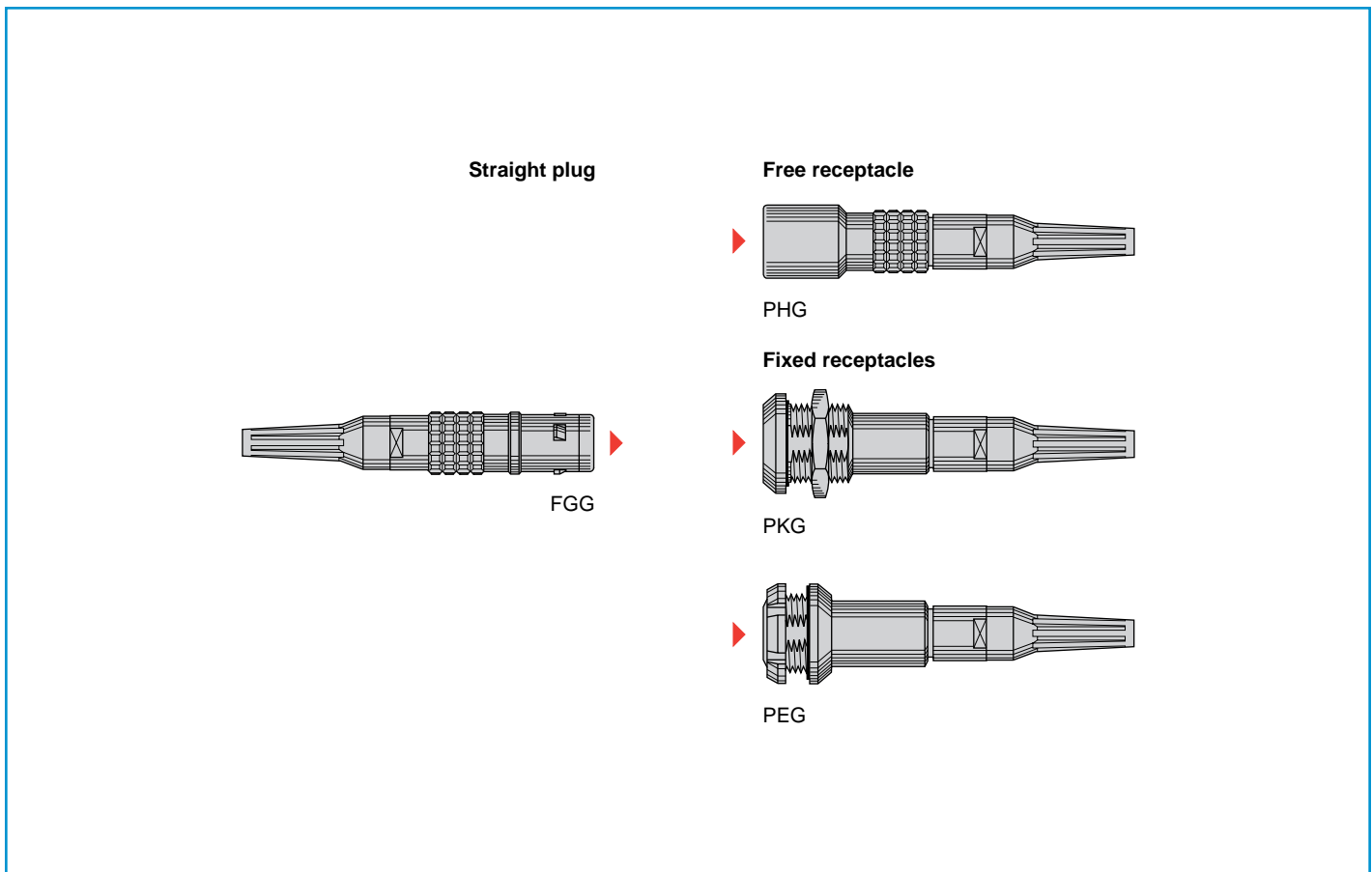

Model Description

FGG Straight plug, key (G) or keys (A...F) and cable adapter, with bend relief
PEG Fixed receptacle, nut fixing, key (G) or keys (A...F) and cable adapter, with bend relief (back panel mounting)

PHG Free receptacle, key (G) or keys (A...F) and cable adapter, with bend relief

PKG Fixed receptacle, nut fixing, key (G) or keys (A...F) and cable adapter, with bend relief

Part Section Showing Internal Components

Connector

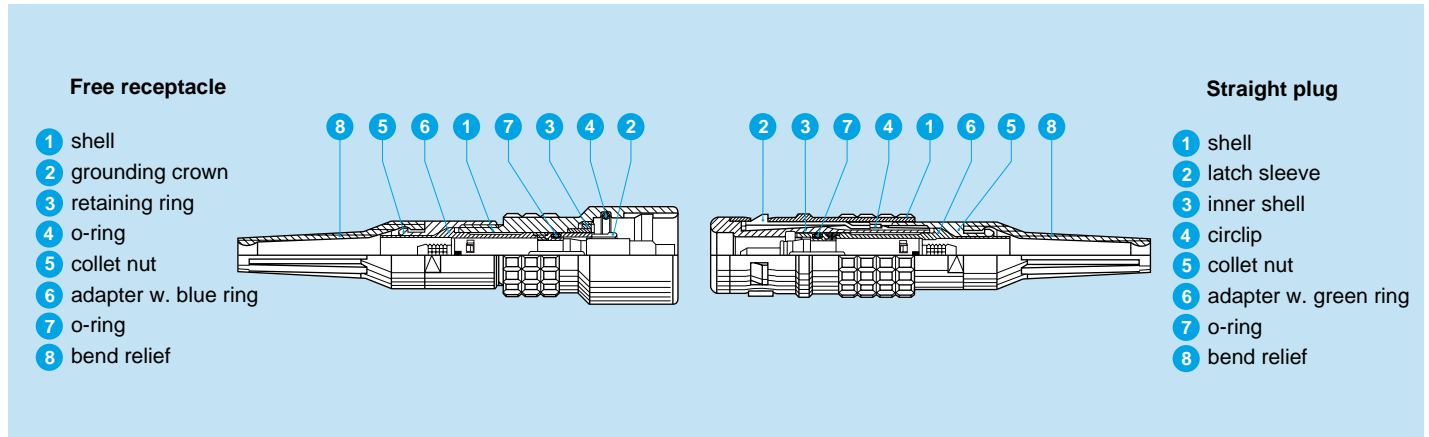

F2 Contact

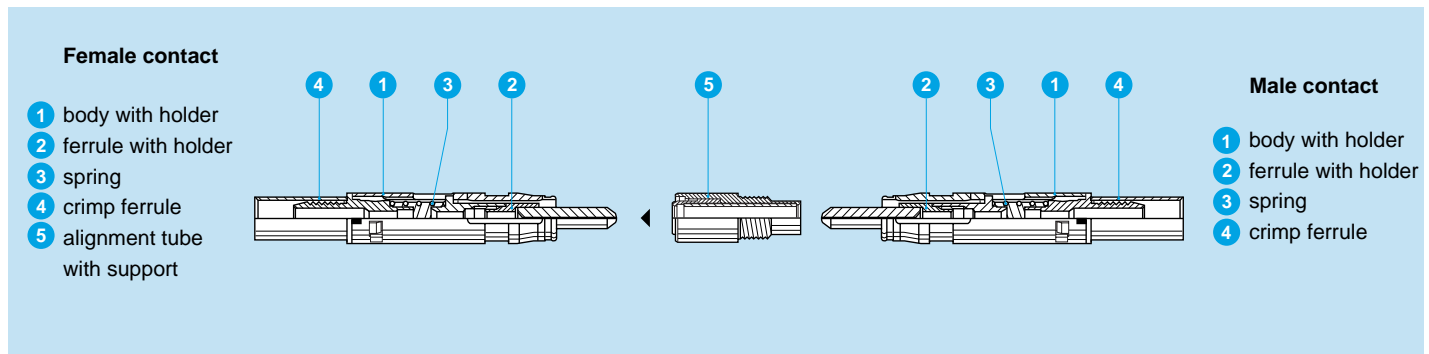

Technical Characteristics

Mechanical and Climatic

Characteristic	Value	Standard
Endurance	5000 cycles	IEC 61300-02-02
Humidity	up to 95 % at 140°F	IEC 61300-02-19
High temperature	+176°F	IEC 61300-02-18
Low temperature	-40°F	IEC 61300-02-17
Protection index (mated)	IP 66-IP 68	IEC 60529
Cable retention	100 N	IEC 61300-02-04
Impact (Method A)	1 m onto concrete floor	IEC 61300-02-12
Shock (3 cycles in 2 directions)	100 g, 10-50 ms; 20 g 6-9 ms	IEC 61300-02-09
Vibration (7 cycles)	Diagram 2 page 16	IEC 61300-02-01

Optical

Characteristic	Value	Standard	Method
Average insertion loss fiber 9/125 μm	0.10 dB	IEC 61300-03-04	Insertion Method B
Average insertion loss fiber 50/125 μm	0.25 dB	IEC 61300-03-04	Insertion Method B
Return loss fiber 9/125 μm (UPC)	≥45 dB	IEC 61300-03-06	Branching Device Met.
Return loss fiber 9/125 μm (Hand polish)	~30 dB	IEC 61300-03-06	Branching Device Met.

Note: Detailed characteristics are presented on inside back cover and pages 15-16.

Alignment Key and Polarized Keying Systems

Front view of a receptacle

Model	No of keys	Angles		Note
●●G	1	α	0°	■
●●A	2		30°	■
●●B	2		45°	■
●●C	2		60°	■
●●D	2	γ	95°	□
●●E	2		120°	□
●●F	2	β	145°	□

■ First choice alternative □ Special order alternative

● Part Number Example

Straight plug with bend relief

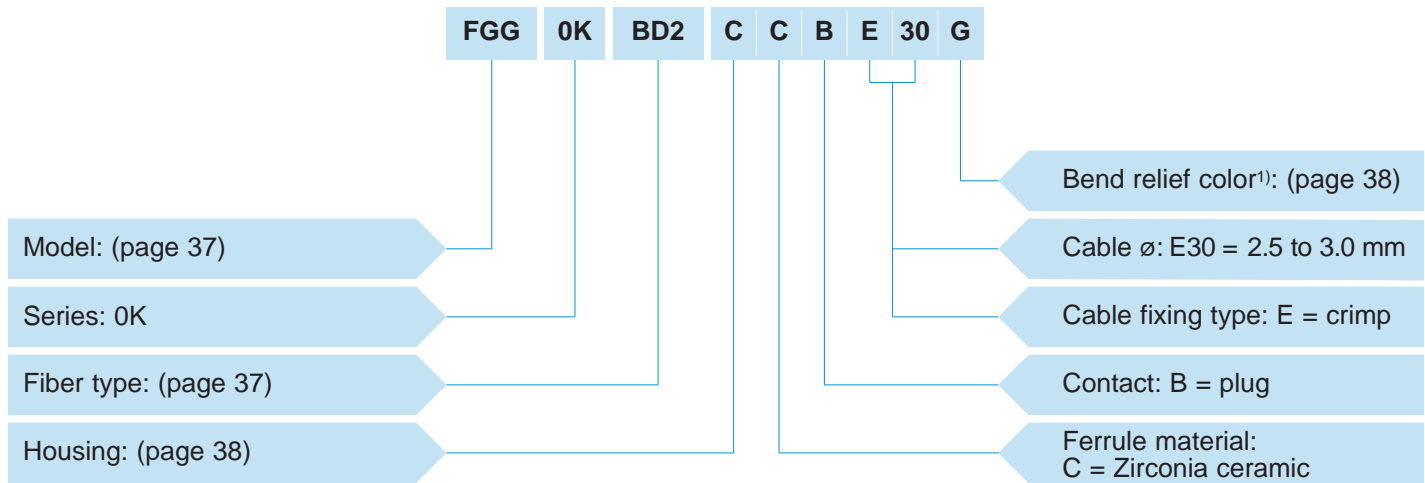

FGG.0K.BD2.CCBE30G = Straight plug with key (G), 0K series, F2 fiber optic contact, ferrule hole ø 128 µm, chrome-plated brass housing, zirconia ceramic ferrule, plug type contact, crimp type cable fixing for 2.5 to 3.0 mm diameter cable, and gray bend relief.

Note: ¹⁾ The bend relief sleeve is necessary to the proper function of the connector thus the connector can only be ordered with the appropriate sleeve.

Free receptacle with bend relief

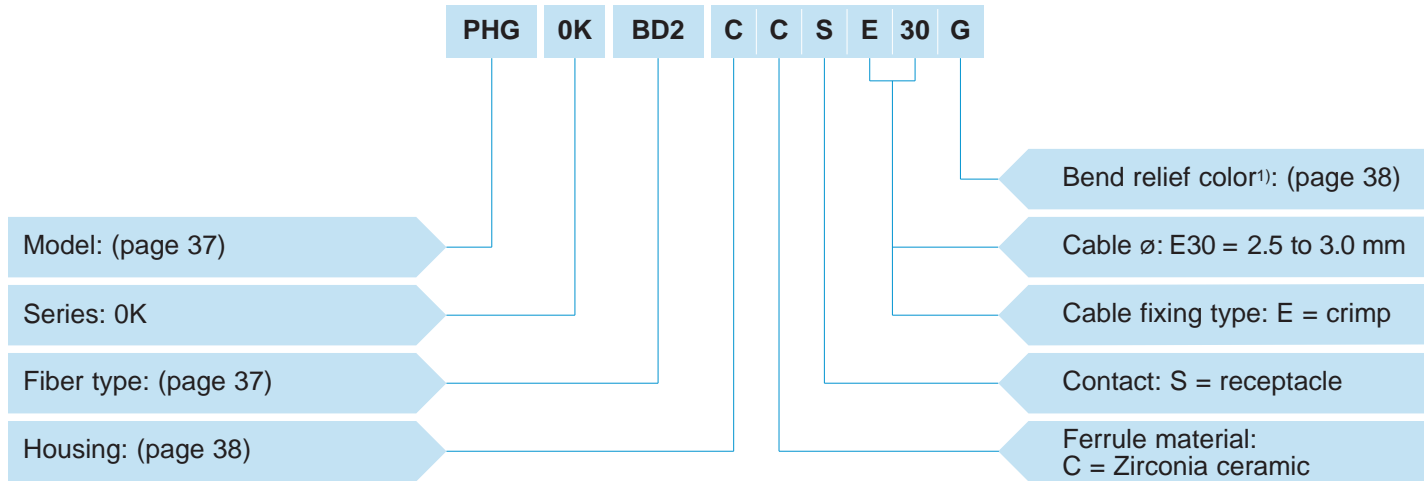

PHG.0K.BD2.CCSE30G = Free receptacle with key (G), 0K series, F2 fiber optic contact, ferrule hole ø 128 µm, chrome-plated brass housing, zirconia ceramic ferrule, receptacle type contact, crimp type cable fixing for 2.5 to 3.0 mm diameter cable, and gray bend relief.

Note: ¹⁾ The bend relief sleeve is necessary to the proper function of the connector thus the connector can only be ordered with the appropriate sleeve.

● Models

FGG.0K Straight plug, key (G) or keys (A...F) and cable adapter, with bend relief

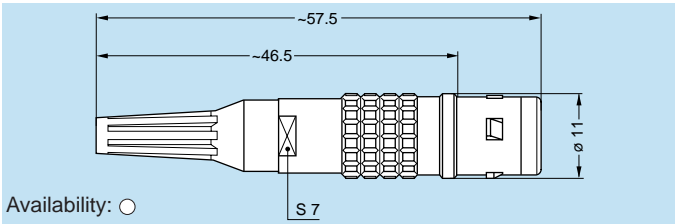

PHG.0K Free receptacle, key (G) or keys (A...F) and cable adapter, with bend relief

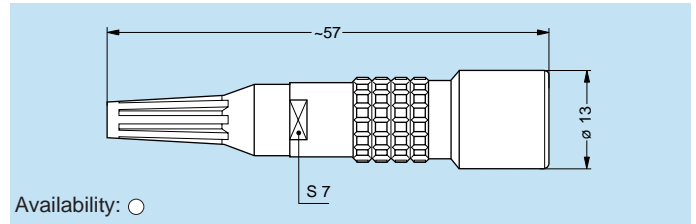
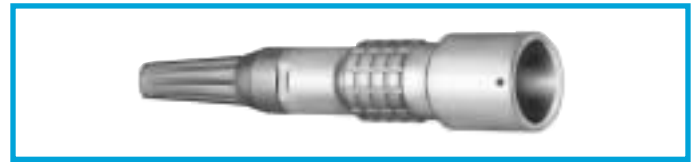

PKG.0K Fixed receptacle, nut fixing, key (G) or keys (A...F) and cable adapter, with bend relief

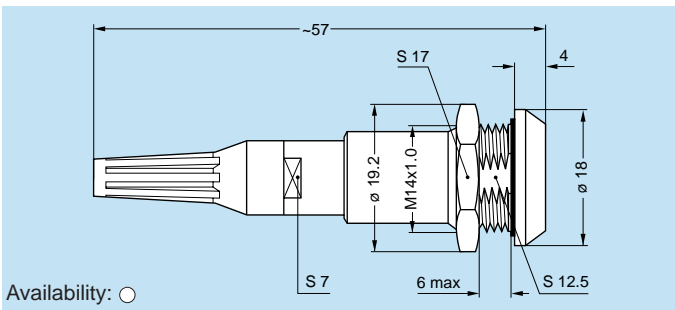

Panel cut-out (page 38)

PEG.0K Fixed receptacle, nut fixing, key (G) or keys (A...F) and cable adapter, with bend relief (back panel mounting)

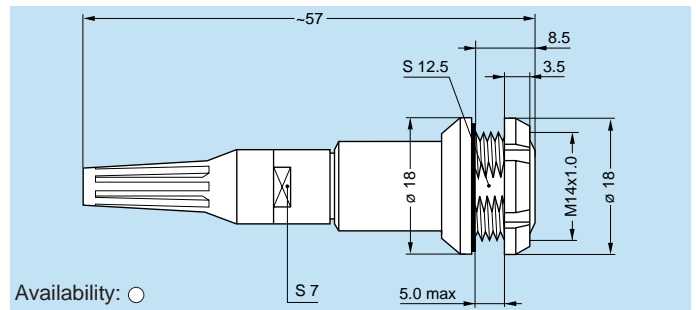
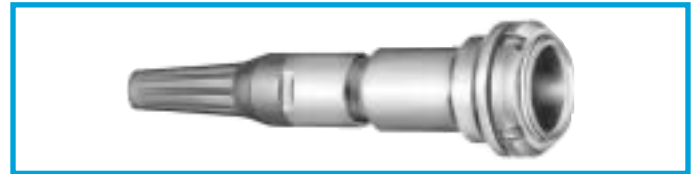

Panel cut-out (page 38)

Note: The overall length dimension is with Desmopan bend relief (see pages 91 and 92).

● Fiber Type

The choice of the ferrule hole diameter is dependent upon the fiber core/cladding size. LEMO offers a range of ferrule hole diameters to suit the users' specific requirements.

Plug or receptacles

The type reference represents the ferrule hole diameter.

Reference	ø Core/Cladding (µm)	Ferrule hole diameter (µm)	Note 1)
BA2	9/125	125	■
BB2	50/125	126	■
BC2	62.5/125	127	□
BD2	100/125	128	□
FA2	100/140	140	□
FB2		144	■

Note:

1) The BA2 type (ferrule hole 125 µm) is recommended for single-mode fibers. The BB2 type (ferrule hole 126 µm) is commonly used with multi-mode fibers.

■ First choice alternative □ Special order alternative

● Housings

Ref.	Material	Surface treatment		Note
		Outer shell and collet nut	Latching sleeve and grounding crown	
C	Brass	chrome	nickel	■
N	Brass	nickel	nickel	□
K	Brass	black chrome	nickel	□
T	Stainless steel	without treatment	stainless steel	□

■ First choice alternative □ Special order alternative

● Bend Relief

All models are supplied with a bend relief. The reference for the color of the bend relief is chosen from the table below and it should be stated in the «bend relief» position of the connector part number.

Ref.	Color
A	blue
B	white

Ref.	Color
G	grey
J	yellow

Ref.	Color
M	brown
N	black

Ref.	Color
R	red
S	orange

Ref.	Color
V	green

● Tooling

The full range of tools for terminating fiber optic F2 contacts of this 0K series is shown on pages 103 to 106. Consult the factory for the termination instructions.

● Panel Cut-Outs

Panel cut-outs

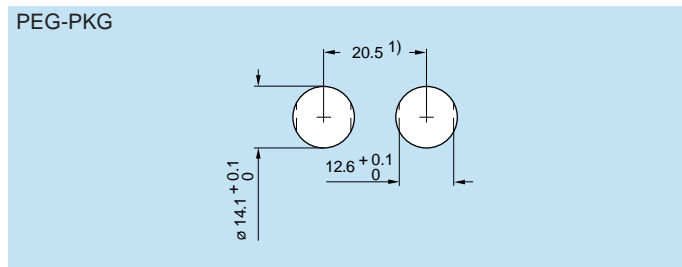

Note: ¹⁾ Minimum distance between two neighboring components.
 Mounting nut torque: **5 Nm**. 1N = 0.102 Kg
 The value shown above is the maximum torque for each connector type.

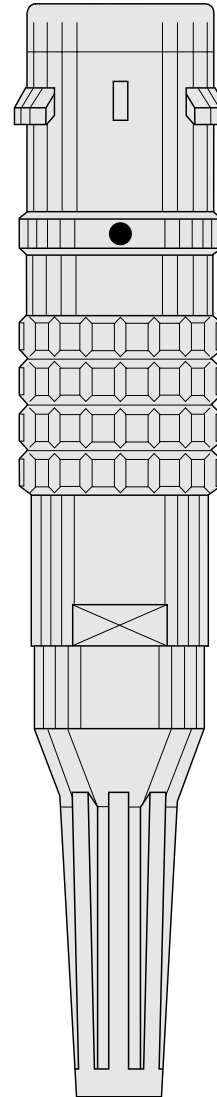
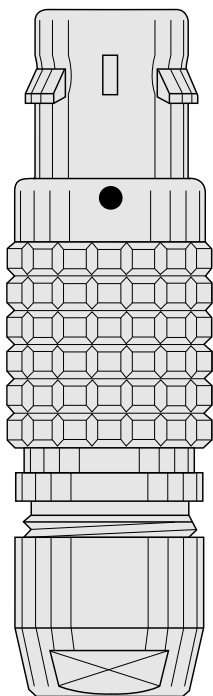
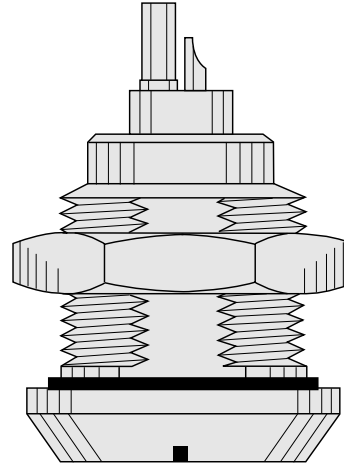
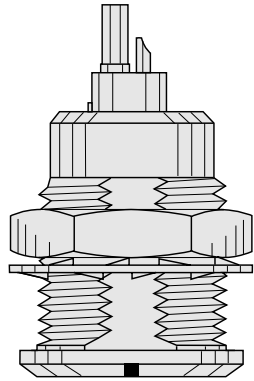

• 2B-5B Series Connectors

• 2K-5K Series Connectors

● 2B-5B Series Connectors

The 2B-5B connectors have been designed to work with the LEMO **F1** or **F2** type fiber optic contacts.

The main features of these series are as follows:

- Security of the LEMO self-latching Quick-Lok™ system
- Protection against accidental contamination or damage to the fiber end face because the ferrules are recessed within the connector shell
- The alignment key (G, A...L, Y and R) ensures excellent repeatability of performance during frequent matings
- A choice of configurations of multi fiber or mixed optical/electrical contacts.

The 2B-5B series consist of fifteen models. The possible outer cable diameters range from 1.5 to 25 mm.

Depending upon the type of fiber optic contact chosen, the connectors can accommodate single-mode fibers in Si/Si 9/125 or multi-mode fibers in silica or plastic with an external diameter up to 1500 µm.

Interconnections

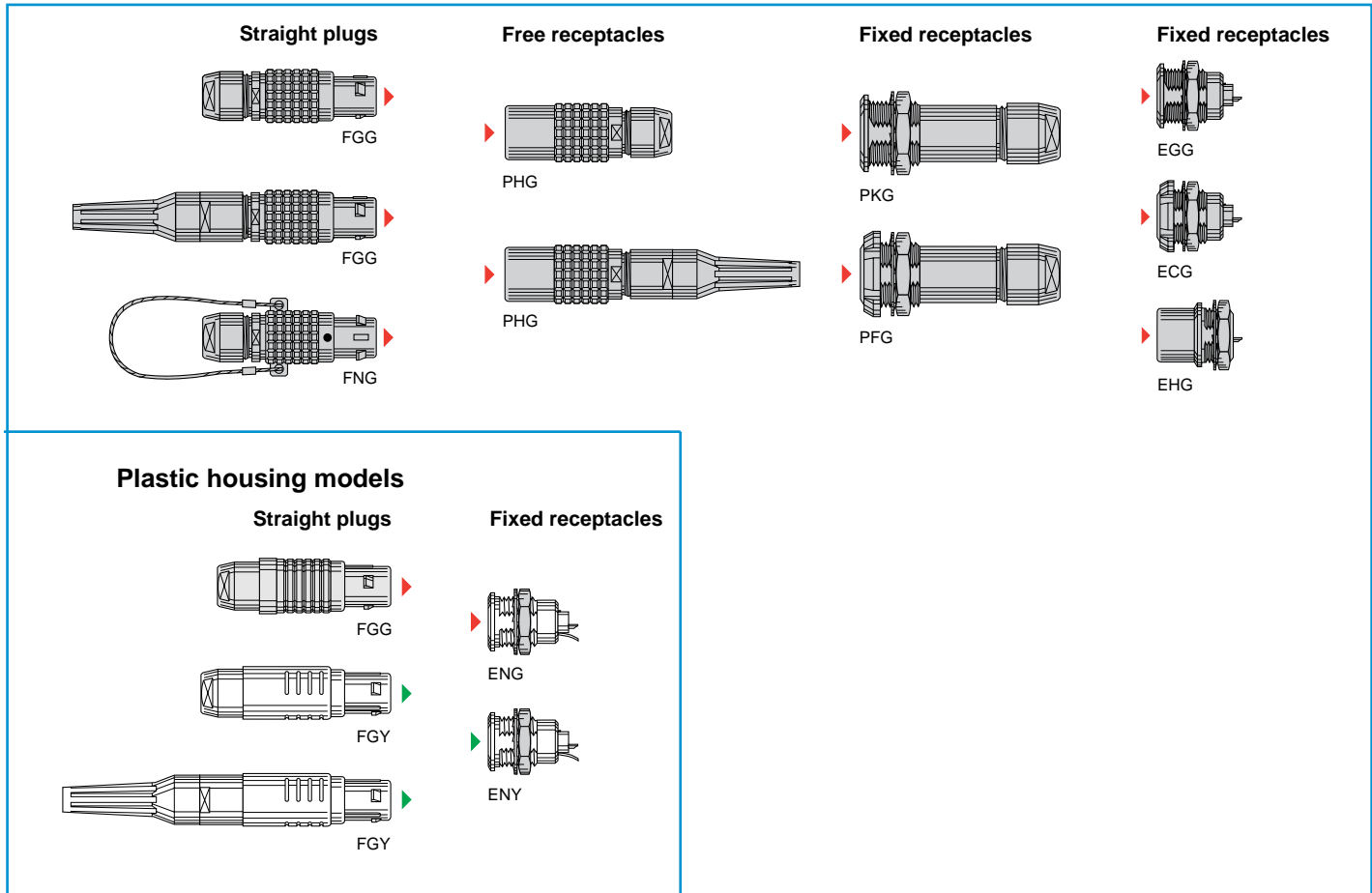

Model Description

- | | | |
|--|--|--|
| ECG Fixed receptacle, with two nuts, key (G) or keys (A...L and R), (back panel mounting) | FGG Straight plug, key (G) or keys (A...L) cable collet and nut for fitting a bend relief | PHG Free receptacle, key (G) or keys (A...L and R) and cable collet |
| EGG Fixed receptacle, nut fixing, key (G) or keys (A...L and R) | FGG Straight plug, key (G or J), cable collet, PEEK outer shell | PHG Free receptacle, key (G) or keys (A...L) and cable collet and nut for fitting a bend relief |
| EHG Fixed receptacle, nut fixing, key (G) or keys (A...L and R) with visible shell | FGY Straight plug, keys (Y), cable collet and PSU or PPSU outer shell | PKG Fixed receptacle, nut fixing, key (G) or keys (A...L and R) and cable collet |
| ENG Fixed receptacle with grounding tab, nut fixing, key (G or J), PEEK outer shell | FGY Straight plug, keys (Y), cable collet and PSU or PPSU outer shell and nut for fitting a bend relief | |
| ENY Fixed receptacle with grounding tab, nut fixing, keys (Y), PSU or PPSU outer shell | FNG Straight plug, key (G) or keys (A...L and R) and cable collet with lanyard release | |
| FGG Straight plug, key (G) or keys (A...L and R) and cable collet | PFG Fixed receptacle, with two nuts, key (G) or keys (A...L and R) and cable collet (back panel mounting) | |

Part Section Showing Internal Components

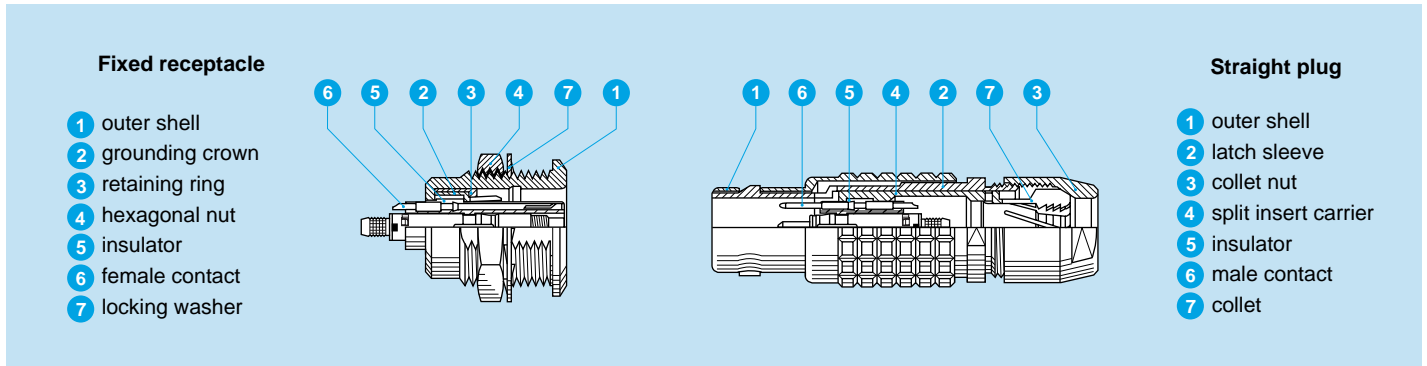

Technical Characteristics

Mechanical and Environmental

Characteristics	Value	Standard
Mating durability	> 5000 cycles	IEC 60512-5 test 9a
Humidity	up 95% to 140°F	
Temperature range	-67°F + 194°F	
Resistance to vibration	10-2000 Hz, 15 g	IEC 60512-4 test 6d
Shock resistance	100 g, 6 ms	IEC 60512-4 test 6c
Salt spray corrosion test ¹⁾	> 144h	IEC 60512-6 test 11f
Protection index (mated)	IP 50	IEC 60529

Note: ¹⁾ The outer shells are in chrome-plated brass (Cr1).

Electrical

Characteristics	Value	Standard	
Shielding efficiency	at 10 MHz	> 75 dB	IEC 60169-1-3
	at 1 GHz	> 40 dB	IEC 60169-1-3

Note:

The various tests have been carried out with FGG and EGG connector pairs, with chrome-plated brass shell and PEEK insulator. Detailed electrical characteristics, as well as materials and treatment are presented on page 9.

Optical

Note: Detailed optical performances for F1 or F2 fiber optic contacts are given on inside back cover and pages 15-16.

Alignment Key and Polarized Keying Systems

Front view of a receptacle	Model	No of keys	Angle	Series				Type of fiber optic or LV contact		Note
				2B	3B	4B	5B	Plug	Receptacle	
				●●G	1	α	0°	0°	0°	
●●A	2	30°	30°	30°	30°		male	female	■	
●●B	2	45°	45°	45°	45°		male	female	■	
●●C	2	60°	60°	60°	60°		male	female	■	
●●D	2	γ	95°	95°	95°	95°	male	female	□	
●●E	2	β	120°	120°	120°	120°	male	female	□	
●●F	2		145°	145°	145°	145°	male	female	□	
●●J	2	α	37.5°	37.5°	37.5°	37.5°	female	male	■	
●●K	2		52.5°	52.5°	52.5°	52.5°	female	male	□	
●●L	2	γ	70°	70°	70°	70°	female	male	□	
●●Y	3	β	112.5°	126°	–	–	male	female	■ ¹⁾	
		γ	100°	102°	–	–				

Front view of a receptacle	Model	No of keys	Angle	Series				Type of fiber optic or LV contact		Note
				2B	3B	4B	5B	Plug	Receptacle	
				●●R	5	α	–	–	–	
β	–	–	–			115°				
γ	–	–	–			20°				
δ	–	–	–			30°				

Note:

FGY, ENY models are not available with all the keys. Please consult pages corresponding to these models.

¹⁾ Only FGY and ENY models are available.

■ First choice alternative □ Special order alternative

Part Number Example

A different part number structure is applicable for each of the following product types:

- Plugs or receptacles for assembly onto cables
- Fixed receptacles.

Straight plug

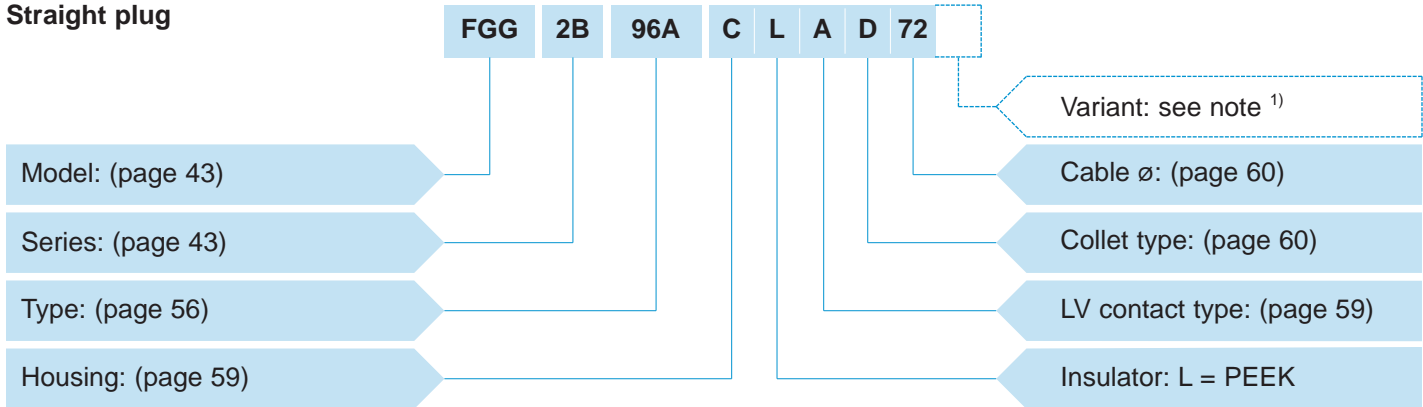

FGG.2B.96A.CLAD72Z = Straight plug with key (G), 2B series, mixed type to accept 1 F1 fiber optic contact and 2 low voltage electrical contacts, chrome-plated brass housing, PEEK insulator, 2 male solder electrical contacts, type D collet system to suit a 7.2 mm diameter cable, and a nut for fitting a bend relief.

Free receptacle

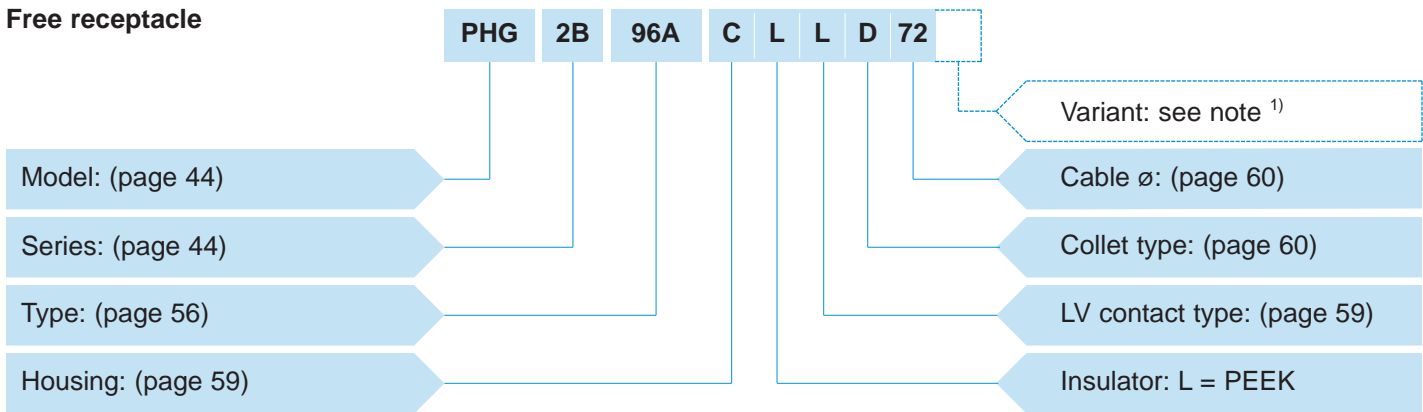

PHG.2B.96A.CLLD72Z = Free receptacle with key (G), 2B series, mixed type to accept 1 F1 fiber optic contact and 2 low voltage electrical contacts, chrome-plated brass housing, PEEK insulator, 2 female solder electrical contacts, type D collet system to suit a 7.2 mm diameter cable, and a nut for fitting a bend relief.

Fixed receptacle

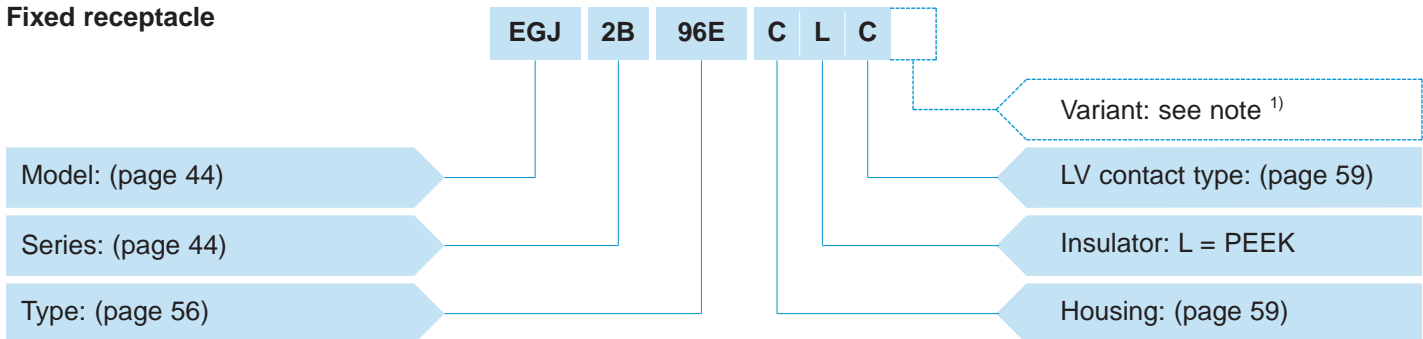

EGJ.2B.96E.CLC = Fixed receptacle with key (code J) 2B series, mixed type to accept 1 F1 fiber optic contact and 6 low voltage electrical contacts, chrome-plated brass housing, PEEK insulator, 6 male crimp electrical contacts.

Connectors are delivered without fiber optic contacts, therefore they must be ordered separately according to the size and type of fiber (see pages 76 and 78). In case of hybrid with coax contacts type C, connectors are delivered without the coax contact. See page 59 for ordering.

Note: ¹⁾ The «Variant» position in the reference is used to specify either the presence of a collet nut for fitting the bend relief, or the anodized color of the housing in aluminum alloy. For models with collet nut for fitting the bend relief, a «Z» should be indicated and a bend relief can be ordered separately as indicated in the «Accessories» section. An order for a connector with bend relief should thus include two part numbers. For the various housings available in colors, the corresponding letter in the part number for the color is indicated on page 62.

● Models

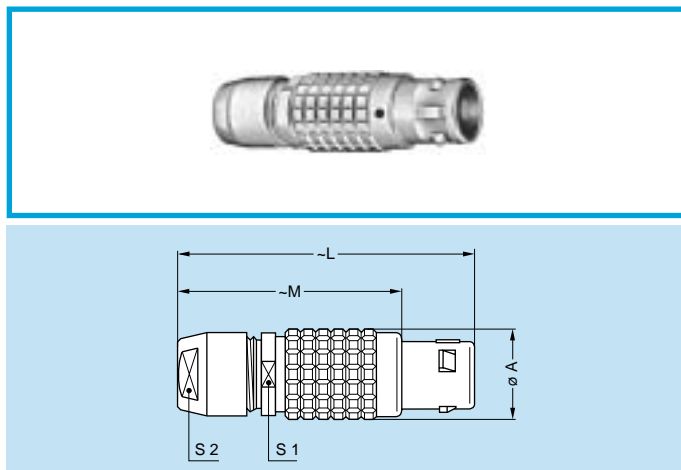

FGG Straight plug, key (G) or keys (A...L and R) and cable collet

Reference		Dimensions (mm)					Availability
Model	Series	A	L	M	S1	S2	
FGG	2B	15	50	38	13	12	○
FGG	3B	18	58	43	15	14	○
FGG	4B	25	75	57	21	20	○
FGG	5B	35	103	78	31	30	○

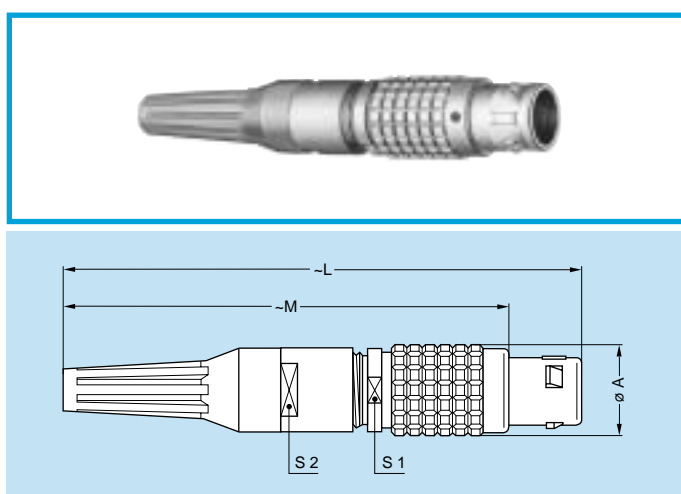

FGG Straight plug, key (G) or keys (A...L) cable collet and nut for fitting a bend relief

Reference		Dimensions (mm)					Availability
Model	Series	A	L	M	S1	S2	
FGG	2B	15	84.0	72.0	13	12	○
FGG	3B	18	98.5	83.5	15	15	○
FGG	4B	25	131.0	113.0	21	20	○
FGG	5B	35	167.5	142.5	31	30	○

Note: The bend relief must be ordered separately (see pages 62 and 91).
The overall length dimension is with Desmopan bend relief (see pages 91 and 92).

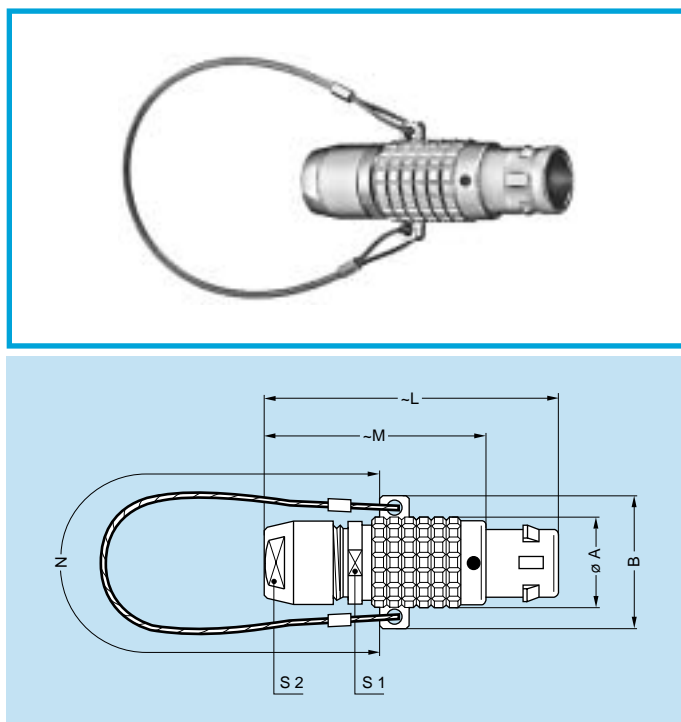

FNG Straight plug, key (G) or keys (A...L and R) and cable collet with lanyard release

Reference		Dimensions (mm)						Availability	
Model	Series	A	B	L	M	N	S1		S2
FNG	2B	15	22.6	49	37	160	13	12	○
FNG	3B	18	25.6	58	43	190	15	14	○
FNG	4B	25	35.2	75	57	230	21	20	○
FNG	5B	35	47.0	103	78	300	31	30	○

Note: Cable material: stainless steel with PVC sheath.

● Standard, typically 0-6 weeks delivery for quantities of 250 or less.
○ Non-standard product, contact LEMO USA, typically 6-12 weeks delivery for quantities of 250 or less.
Non-standard product is defined as any product which contains one or more components which are not standard.

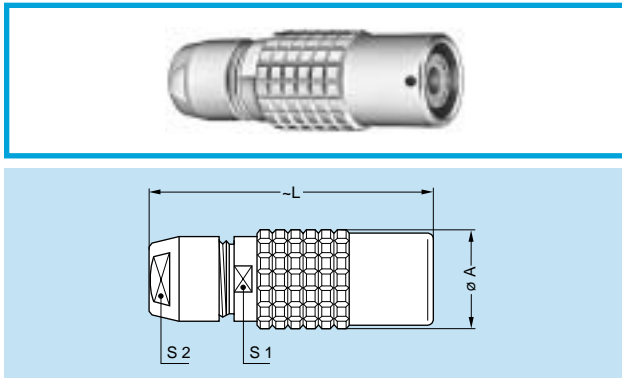

PHG Free receptacle, key (G) or keys (A...L and R) and cable collet

Reference		Dimensions (mm)				Availability
Model	Series	A	L	S1	S2	
PHG	2B	16.5	47	13	12	○
PHG	3B	19.0	56	15	14	○
PHG	4B	24.4	73	21	20	○
PHG	5B	34.2	99	31	30	○

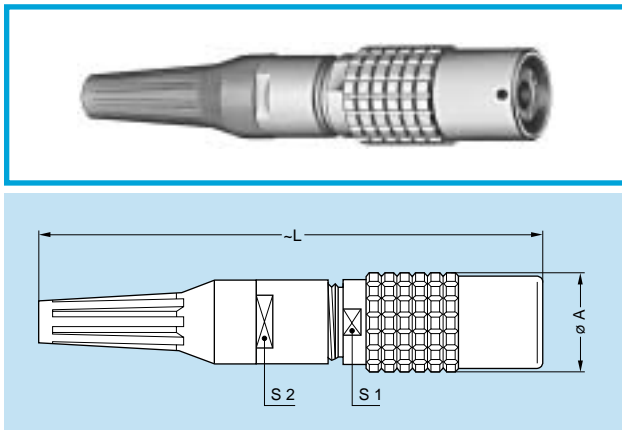

PHG Free receptacle, key (G) or keys (A...L) and cable collet and nut for fitting a bend relief

Reference		Dimensions (mm)				Availability
Model	Series	A	L	S1	S2	
PHG	2B	16.5	82.0	13	12	○
PHG	3B	19.0	96.5	15	15	○
PHG	4B	24.4	129.0	21	20	○
PHG	5B	34.2	163.5	31	30	○

Note: The bend relief must be ordered separately (see pages 62 and 91). The overall length dimension is with Desmopan bend relief (see pages 91 and 92).

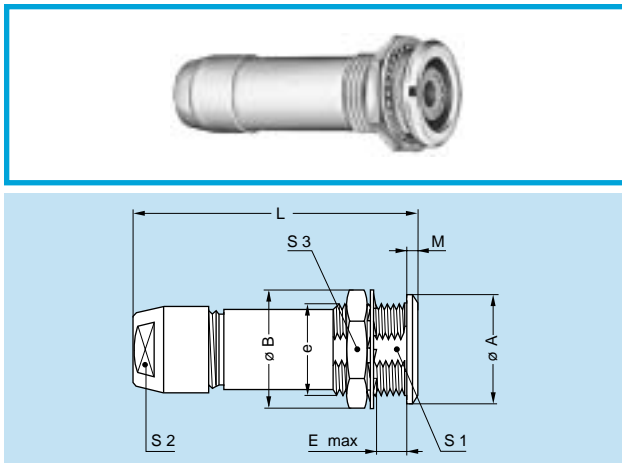

PKG Fixed receptacle, nut fixing, key (G) or keys (A...L and R) and cable collet

Reference		Dimensions (mm)									Availability
Model	Series	A	B	e	E	L	M	S1	S2	S3	
PKG	2B	18	19.2	M15x1	8.5	47	1.8	13.5	12	17	○
PKG	3B	22	25.0	M18x1	11.5	56	2.0	16.5	14	22	○
PKG	4B	28	34.0	M25x1	12.5	73	2.5	23.5	20	30	○
PKG	5B	40	40.0	M35x1	11.0	99	3.0	33.5	30	-	○

Panel cut-out: **P1** (see page 48)

Note: The 5B series is delivered with a tapered washer and a round nut (see pages 94 and 95).

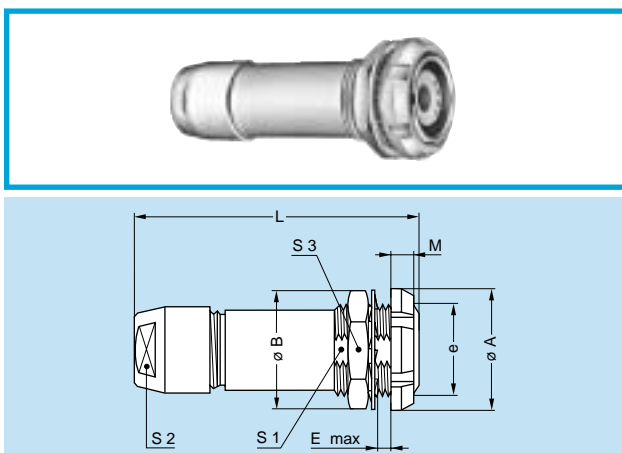

PFG Fixed receptacle, with two nuts, key (G) or keys (A...L and R) and cable collet, (back panel mounting)

Reference		Dimensions (mm)									Availability
Model	Series	A	B	e	E	L	M	S1	S2	S3	
PFG	2B	20	19.2	M15x1	6.5	47	3.5	13.5	12	17	○
PFG	3B	24	25.0	M18x1	9.0	56	4.5	16.5	14	22	○
PFG	4B	30	34.0	M25x1	11.0	73	4.5	23.5	20	30	○
PFG	5B	41	40.0	M35x1	10.0	99	5.0	33.5	30	-	○

Panel cut-out: **P1** (see page 48)

Note: The 3B, 4B and 5B series are delivered with a conical nut. The 5B series is delivered with a tapered washer and a round nut (see pages 94 and 95).

● Standard, typically 0-6 weeks delivery for quantities of 250 or less.
○ Non-standard product, contact LEMO USA, typically 6-12 weeks delivery for quantities of 250 or less.
Non-standard product is defined as any product which contains one or more components which are not standard.

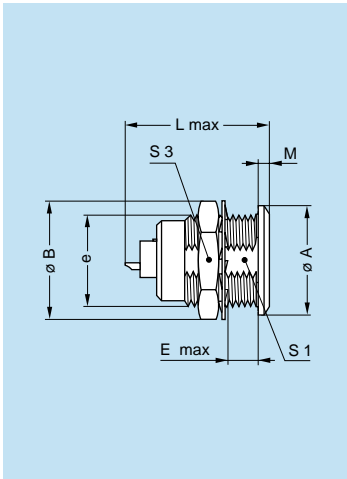

EGG Fixed receptacle, nut fixing, key (G) or keys (A...L and R)

Reference		Dimensions (mm)									Availability
Model	Series	A	B	e	E	L max ¹⁾		M	S1	S3	
						F1	F2				
EGG	2B	18	19.2	M15x1	8.5	27.0	37.0	1.8	13.5	17	○
EGG	3B	22	25.0	M18x1	11.5	30.0	37.0	2.0	16.5	22	○
EGG	4B	28	34.0	M25x1	12.0	34.5	38.5	2.5	23.5	30	○
EGG	5B	40	40.0	M35x1	11.0	36.5	38.0	3.0	33.5	-	○

Panel cut-out: **P1** (see page 48)

Note: ¹⁾ The overall length (L) may vary depending upon the type of electrical LV or fiber optic contact fitted. The 5B series is delivered with a tapered washer and a round nut (see pages 94 and 95).

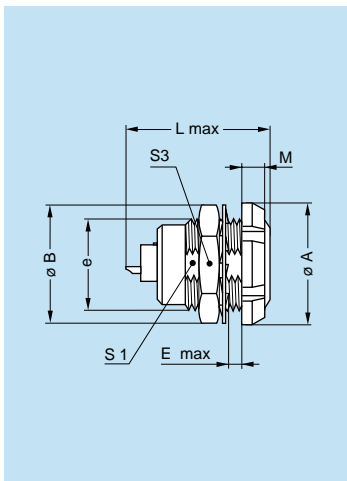

ECG Fixed receptacle, with two nuts, key (G) or keys (A...L and R), (back panel mounting)

Reference		Dimensions (mm)									Availability
Model	Series	A	B	e	E	L max ¹⁾		M	S1	S3	
						F1	F2				
ECG	2B	20	19.2	M15x1	6.5	27.0	37.0	3.5	13.5	17	○
ECG	3B	24	25.0	M18x1	9.0	30.0	37.0	4.5	16.5	22	○
ECG	4B	30	34.0	M25x1	10.0	34.5	38.5	4.5	23.5	30	○
ECG	5B	41	40.0	M35x1	9.0	36.5	38.0	5.0	33.5	-	○

Panel cut-out: **P1** (see page 48)

Note: ¹⁾ The overall length (L) may vary depending upon the type of electrical LV or fiber optic contact fitted. The 3B, 4B and 5B series are delivered with a conical nut. The 5B series is delivered with a tapered washer and a round nut (see pages 94 and 95).

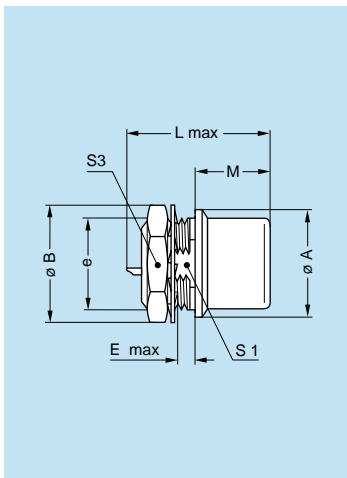

EHG Fixed receptacle, nut fixing, key (G) or keys (A...L and R), visible shell

Reference		Dimensions (mm)									Availability
Model	Series	A	B	e	E	L max ¹⁾		M	S1	S3	
						F1	F2				
EHG	2B	18	19.2	M15x1	5.2	27.0	37.0	12.5	13.5	17	○
EHG	3B	22	25.0	M18x1	4.2	30.0	37.0	12.5	16.5	22	○
EHG	5B	40	40.0	M35x1	2.5	36.5	38.0	28.5	33.5	-	○

Panel cut-out: **P1** (see page 48)

Note: ¹⁾ The overall length (L) may vary depending upon the type of electrical LV or fiber optic contact fitted. The 5B series is delivered without locking washer or tapered washer and with a round nut (see pages 94 and 95).

Plastic housing models

FGG, FGY, ENG and ENY plug and receptacle models are available with the outer shell and collet nut made with various insulating materials.

These connectors are particularly recommended for all applications requiring maximum electrical insulation when mated. The design, including a latch sleeve and a metal grounding crown, guarantees EMC screening efficiency to meet most requirements.

Technical Characteristics

Mechanical and Environmental

Characteristics	Value			Standard
	PEEK	PSU	PPSU	
Color	natural (beige)	white or grey	cream	–
Endurance	> 5000 cycles	> 5000 cycles	> 5000 cycles	IEC 60512-5 test 9a
Humidity	up to 95% at 140°F			–
Temperature range	-58°F/+482°F	-58°F/+302°F	-58°F/+356°F	–
Sterilization resistance ¹⁾	~200 cycles	~20 cycles	~100 cycles	IEC 60601-1 § 44.7
Resistance to solvents	very good	limited	good	–

Note: 1) Steam sterilization

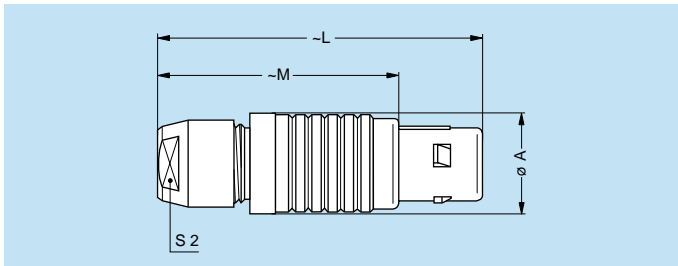

FGG Straight plug, key (G or J), cable collet, PEEK outer shell

Reference		Dimensions (mm)				Availability
Model	Series	A	L	M	S2	
FGG	3B	19.0	62.0	47.0	15	○
FGG	4B	26.0	78.5	60.5	20	○

Note: Model also available with a nut for fitting a bend relief.

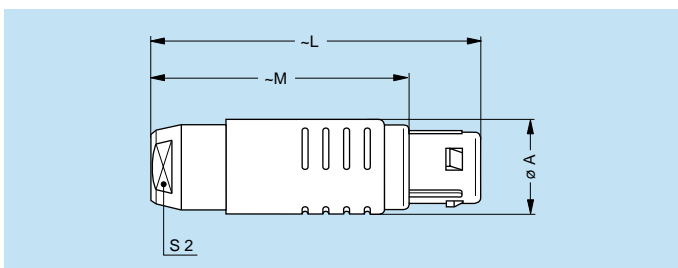

FGY Straight plug, keys (Y), cable collet and PSU or PPSU outer shell

Reference		Dimensions (mm)				Availability
Model	Series	A	L	M	S2	
FGY	2B	16.5	50.5	39.5	13	○
FGY	3B	19.0	58.0	43.0	15	○
FGY	4B	26.0	76.2	58.2	20	○

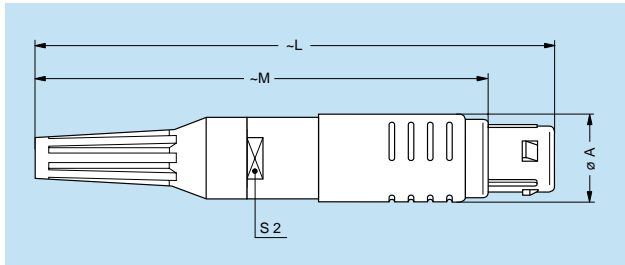

FGY Straight plug, keys (Y), cable collet and PSU or PPSU outer shell and nut for fitting a bend relief

Reference		Dimensions (mm)				Availability
Model	Series	A	L	M	S2	
FGY	2B	16.5	81	70	13	○
FGY	3B	19.0	94	79	15	○

Note: The bend relief must be ordered separately (see pages 62 and 91).
The overall length dimension is with Desmopan bend relief (see pages 91 and 92).

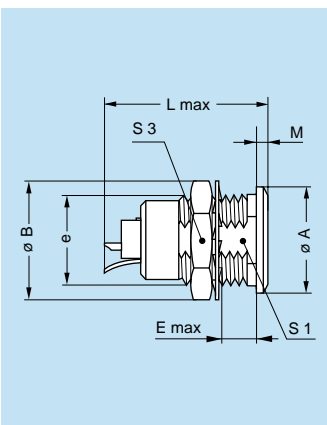

ENG Fixed receptacle with grounding tab, nut fixing, key (G or J), PEEK outer shell

Reference		Dimensions (mm)								Availability	
Model	Series	A	B	e	E	L max ¹⁾		M	S1		S3
						F1	F2				
ENG	3B	22	25.0	M18x1	11.5	30.0	37.0	2.0	16.5	22	○
ENG	4B	28	34.0	M25x1	12.0	34.5	38.5	2.5	23.5	30	○

Panel cut-out: **P1** (see page 48)

Note: ¹⁾ The overall length (L) may vary depending upon the type of electrical LV or fiber optic contact fitted.

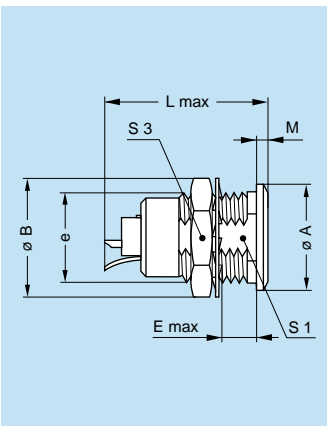

ENY Fixed receptacle with grounding tab, nut fixing, keys (Y), PSU or PPSU outer shell

Reference		Dimensions (mm)								Availability	
Model	Series	A	B	e	E	L max ¹⁾		M	S1		S3
						F1	F2				
ENY	2B	18	19.2	M15x1	8.5	27.0	37.0	1.8	13.5	17	○
ENY	3B	22	25.0	M18x1	11.5	30.0	37.0	2.0	16.5	22	○
ENY	4B	28	34.0	M25x1	12.0	34.5	38.5	2.5	23.5	30	○

Panel cut-out: **P1** (see page 48)

Note: ¹⁾ The overall length (L) may vary depending upon the type of electrical LV or fiber optic contact fitted.

Note: Other models with plastic outer shell are available on request.

● Tooling

Fiber optic contacts

The full range of tools for terminating fiber optic contacts F1 or F2 used with these 2B-5B series is shown on pages 103 to 106.

Consult the factory for the termination instructions.

Electrical contacts

The specific tools that may be used for the termination of crimp LV contacts or the type C coax contacts are shown on pages 100 to 102.

● Panel Cut-Outs

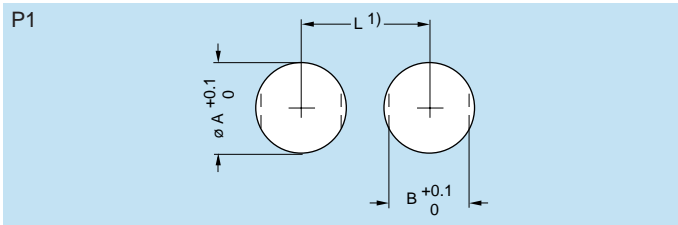

Series	Dimensions (mm)		
	A	B	L
2B	15.1	13.6	21.5
3B	18.2	16.6	27.0
4B	25.2	23.6	34.0
5B	35.2	33.6	44.0

Note: ¹⁾ Minimum distance between two neighboring components.

Mounting torque

Series	Torque (Nm)		
	Metal shell	Metal shell with GRA insulating washer	Plastic shell
2B	6.0	0.8	0.8
3B	9.0	1.0	1.0
4B	12.0	5.0	5.0
5B	17.0	–	–

Note: The values shown in the table above are the maximum torque for each connector type.

1N = 0.102 Kg

● 2K-5K Series

The 2K-5K series connectors are designed to work with the LEMO **F1** or **F2** fiber optic contacts.

The main features of these series are as follows:

- Security of the LEMO self-latching Quick-Lok™ system
- Specially designed for outdoors applications. All these models are waterproof when mated and reach a protection index of IP 66-IP 68, according to the IEC 60529 standard
- Protection against accidental contamination or damage to the fiber end face because the ferrules are recessed within the connector shell
- The alignment key (G, A...F, L and R) ensures excellent repeatability of performance during frequent matings
- A choice of configurations of multi fiber or mixed optical/electrical contacts.

The 2K-5K series consists of ten models which will accept outer cable diameters ranging from 3.6 mm to 23.5 mm.

Depending upon the type of fiber optic contact chosen, the connectors can accommodate single-mode fibers in Si/Si 9/125 or multi-mode fibers in silica or plastic with dimensions reaching 1500 µm.

Interconnections

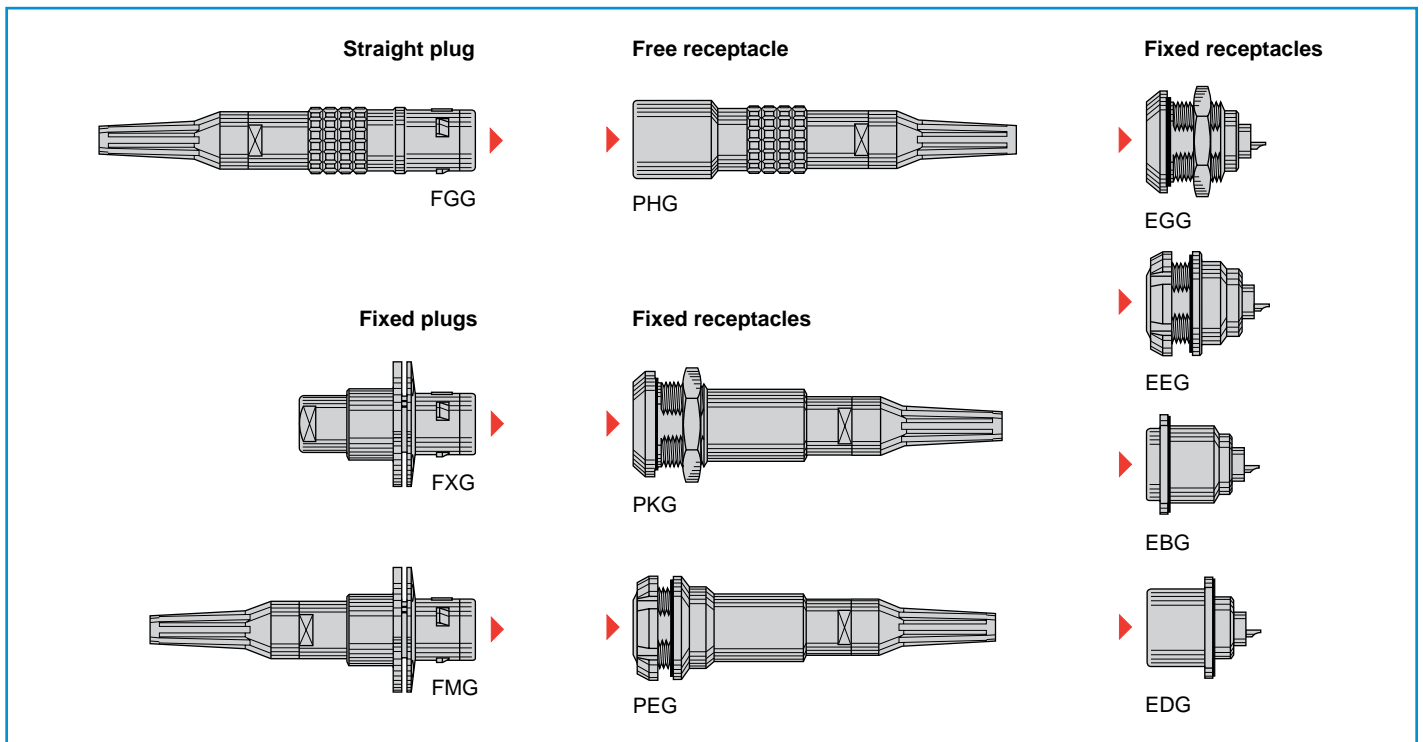

Model Description

- EBG** Fixed receptacle with square flange, key (G) or keys (A...F, L and R), four holes fixing
- EDG** Fixed receptacle with square flange, key (G) or keys (A...F, L and R), protruding shell and earthing tag, screw fixing
- EEG** Fixed receptacle, nut fixing, key (G) or keys (A...F, L and R) (back panel mounting)
- EGG** Fixed receptacle, nut fixing, key (G) or keys (A...F, L and R)

- FGG** Straight plug, key (G) or keys (A...F, L and R), cable adapter and nut for fitting a bend relief
- FMG** Fixed plug with round flange, four holes fixing, key (G) or keys (A...F, L and R), cable adapter and nut for fitting a bend relief
- FXG** Fixed plug with round flange, four holes fixing, key (G) or keys (A...F, L and R)
- PEG** Fixed receptacle, nut fixing, key (G) or keys (A...F, L and R), cable adapter and nut for fitting a bend relief

- (back panel mounting)
- PHG** Free receptacle, key (G) or keys (A...F, L and R), cable adapter and nut for fitting a bend relief
- PKG** Fixed receptacle, nut fixing, key (G) or keys (A...F, L and R), cable adapter and nut for fitting a bend relief

Part Section Showing Internal Components

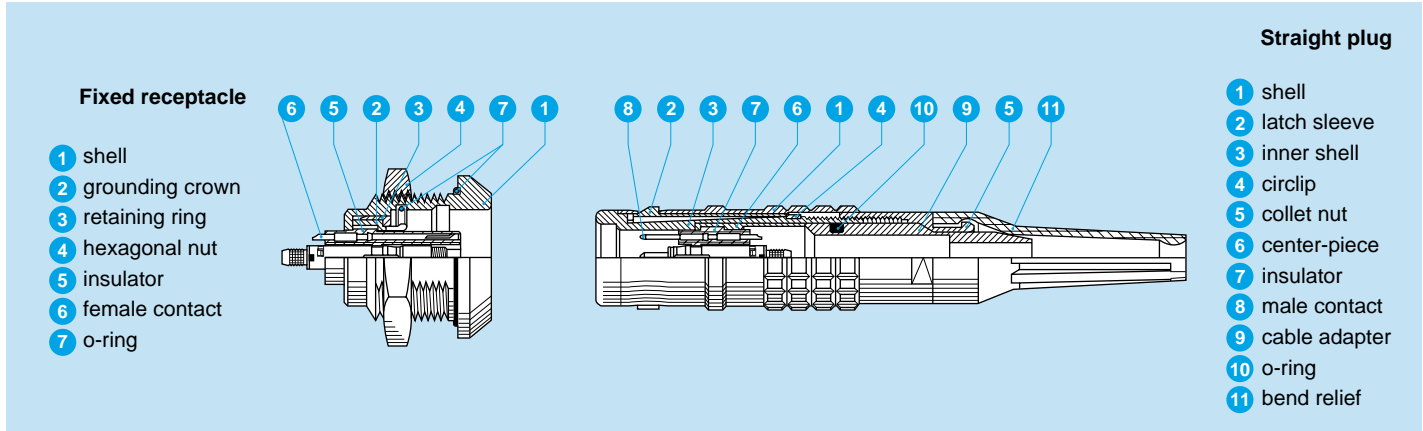

Technical Characteristics

Mechanical and Environmental

Characteristics	Value	Standard
Mating durability	> 5000 cycles	IEC 60512-5 test 9a
Humidity	up to 95% at 140°F	
Temperature range	-58°F + 392°F	
Resistance to vibrations	10-2000 Hz, 15 g	IEC 60512-4 test 6d
Shock resistance	100 g, 6 ms	IEC 60512-4 test 6c
Salt spray corrosion test ¹⁾	> 144h	IEC 60512-6 test 11f
Protection index (mated)	IP 68/IP 66	IEC 60529

Note: ¹⁾ The outer shells are in chrome-plated brass (Cr1). The various tests have been carried out with FGG and EGG connector pairs, with chrome-plated brass shell, PEEK insulator and silicone O-ring. Detailed electrical characteristics, as well as materials and treatment are presented on page 7.

Electrical

Characteristics	Value	Standard
Shielding efficiency	at 10 MHz	> 95 dB
	at 1 GHz	> 80 dB

Optical

Note: Detailed optical performances for F1 or F2 fiber optic contacts are given on inside back cover and pages 15-16.

Alignment Key and Polarized Keying Systems

Front view of a receptacle 	Model	No of keys	Angles	Series				Type of electrical or fiber optic contact		Note
				2K	3K	4K	5K	Plug	Receptacle	
				●●G	1	α	0°	0°	0°	
●●A	2	30°	30°	30°	30°		male	female	■	
●●B	2	45°	45°	45°	45°		male	female	■	
●●C	2	60°	60°	60°	60°		male	female	■	
●●D	2	γ	95°	95°	95°	95°	male	female	□	
●●E	2		120°	120°	120°	120°	male	female	□	
●●F	2	β	145°	145°	145°	145°	male	female	□	
●●L	2		γ	75°	75°	75°	75°	female	male	■

Front view of a receptacle 	Model	No of keys	Angles	Series				Type of electrical or fiber optic contact		Note
				2K	3K	4K	5K	Plug	Receptacle	
				●●R	5	α	–	95°	–	
β	–	115°	–	–						
γ	–	35°	–	–						
δ	–	25°	–	–						

■ First choice alternative □ Special order alternative

● Part Number Example

A different part number structure is applicable for each of the following product types:

- Plugs and free receptacles for assembly onto cables
- Fixed receptacles.

Straight plug with bend relief

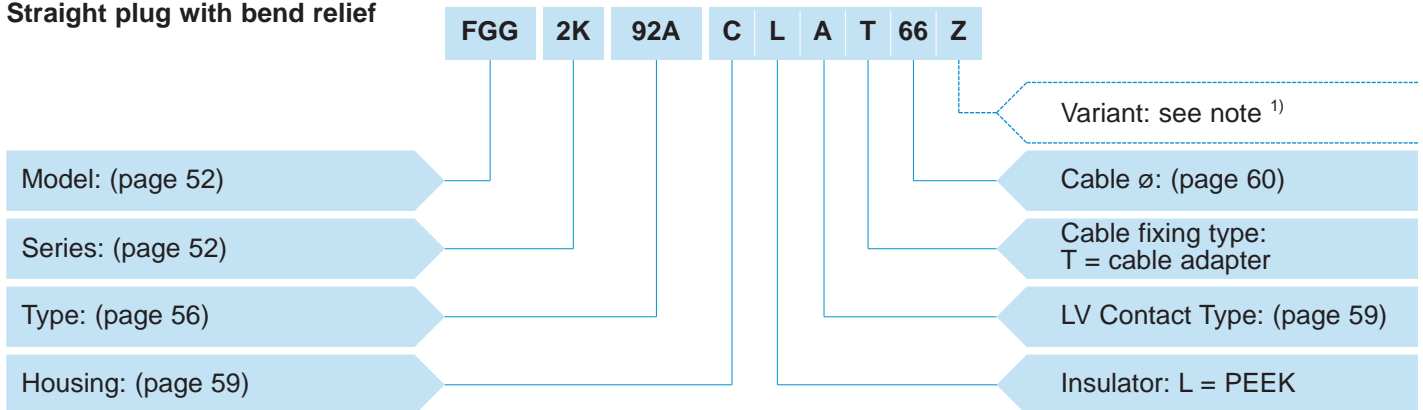

FGG.2K.92A.CLAT66Z = Straight plug with key (G), 2K series, mixed type to accept 1 F2 type fiber optic contact and 2 low voltage contacts, chrome-plated brass housing, PEEK insulator, 2 male solder electrical contacts, cable fixing type T for 6.5 mm diameter cable, and nut for fitting a bend relief.

Free receptacle with bend relief

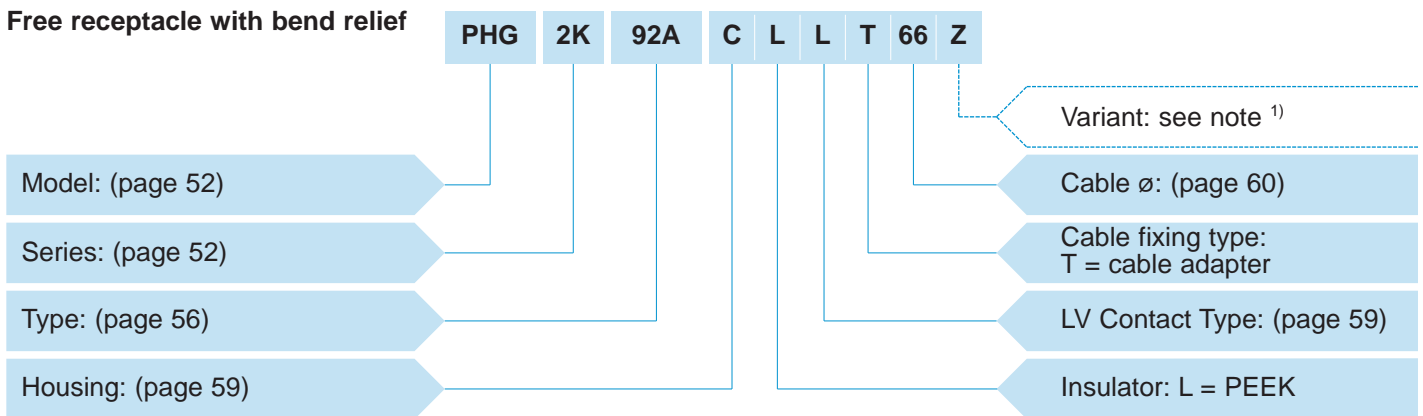

PHG.2K.92A.CLLT66Z = Free receptacle with key (G), 2K series, mixed type to accept 1 F2 type fiber optic contact and 2 low voltage contacts, chrome-plated brass housing, PEEK insulator, 2 female solder electrical contacts, cable fixing type T for 6.5 mm diameter cable, and nut for fitting a bend relief.

Fixed receptacle

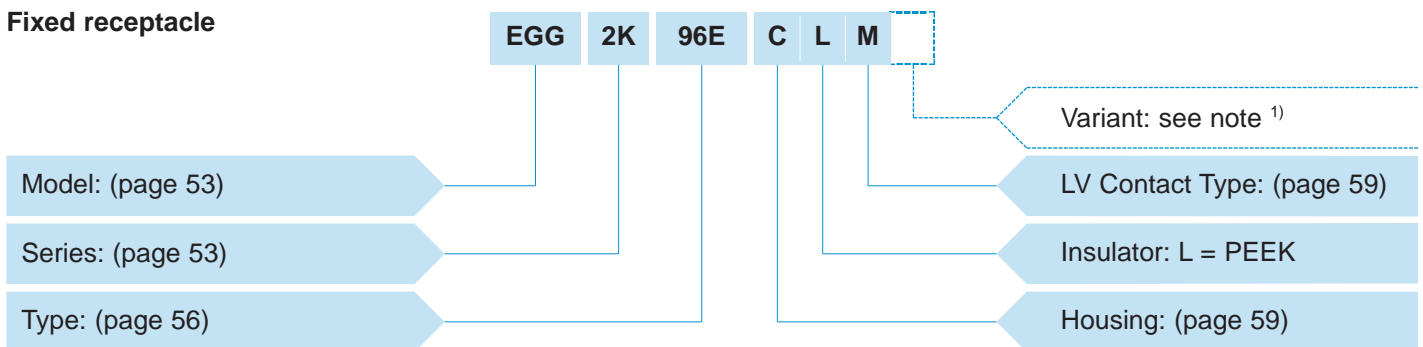

EGG.2K.96E.CLM = Fixed receptacle with key (G), 2K series, mixed type to accept take 1 F1 type fiber optic contact and 6 low voltage contacts, chrome-plated brass housing, PEEK insulator, 6 female crimp electrical contacts.

Connectors are delivered without fiber optic contacts, therefore they must be ordered separately according to the size and type of fiber (see pages 76 and 78). In case of hybrid (with coax contacts type C), connectors are delivered without the coax contact. See page 59 for ordering.

Note: ¹⁾ The «Variant» position in the reference is used to indicate the presence of a collet nut for fitting the bend relief. For models with the «T» type of cable adapter the «Z» should always be indicated and a bend relief can be ordered separately as indicated in the «Accessories» section. An order for a connector with bend relief should thus include two part numbers. For various housings available in colors, the corresponding letter in the part number for the color is indicated on page 62.

● Models

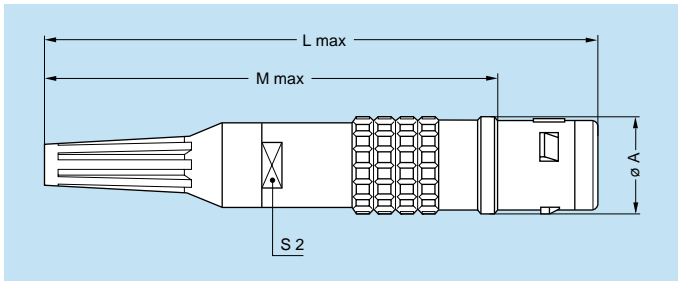
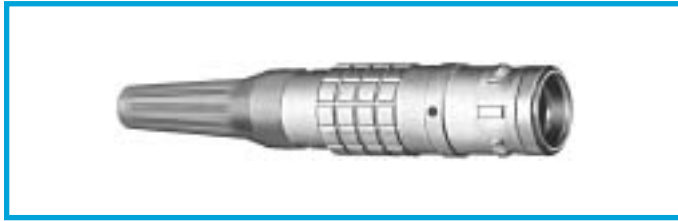

FGG Straight plug, key (G) or keys (A...F, L and R), cable adapter and nut for fitting a bend relief

Reference		Dimensions (mm)				Availability
Model	Series	A	L	M	S2	
FGG	2K	16	101	85.0	12	○
FGG	3K	19	109	89.0	15	○
FGG	4K	25	131	110.5	19	○
FGG	5K	38	160	135.0	30	○

Note: The overall length dimension is with Desmopan bend relief (see pages 91 and 92).

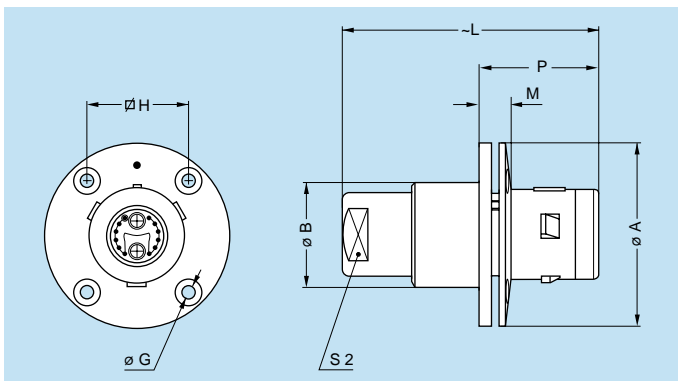
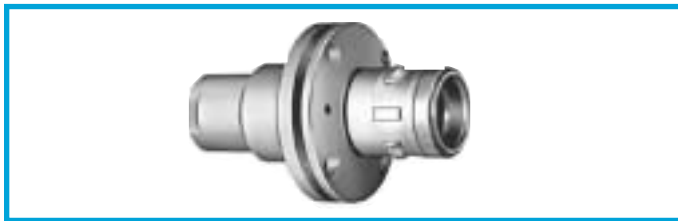

FXG Fixed plug with round flange, four holes fixing, key (G) or keys (A...F, L and R)

Reference		Dimensions (mm)								Availability
Model	Series	A	B	G	H	L	M	P	S2	
FXG	3K	38	22.5	3.4	20.6	61	10.0	30.0	15	○
FXG	4K	47	28.5	3.4	27.0	71	11.0	32.0	19	○
FXG	5K	65	42.5	4.4	38.0	100	12.5	38.5	30	○

Panel cut-out: **P2** (see page 55)

Note: This model does not include an O-ring behind the flange, it allows the device on which it is fitted to reach only IP50 protection index. It does not have a cable adapter.

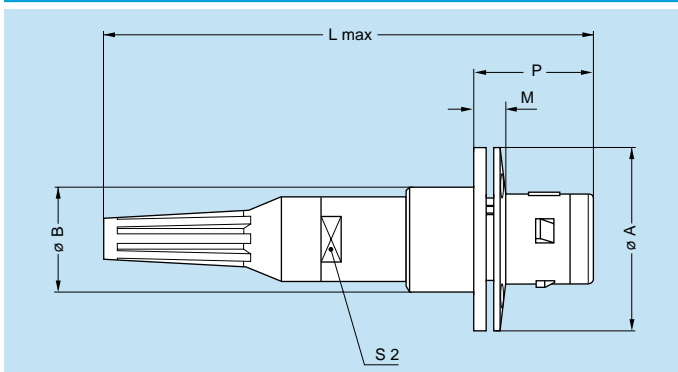
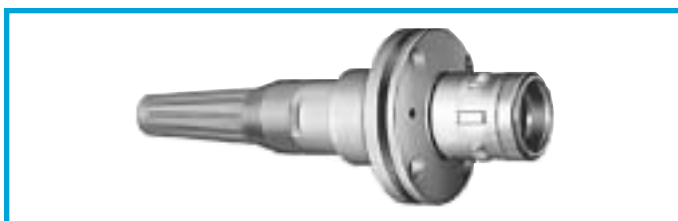

FMG Fixed plug with round flange, four hole fixing, key (G) or keys (A...F, L and R), cable adapter and nut for fitting a bend relief

Reference		Dimensions (mm)								Availability
Model	Series	A	B	G ¹⁾	H ¹⁾	L	M	P	S2	
FMG	3K	38	22.5	3.4	20.6	109.0	10.0	30.0	15	○
FMG	4K	47	28.5	3.4	27.0	131.0	11.0	32.0	19	○
FMG	5K	65	42.5	4.4	38.0	163.5	12.5	38.5	30	○

Panel cut-out: **P2** (see page 55)

Note: ¹⁾ See FXG drawing for front view. This model does not include an O-ring behind the flange, it allows the device on which it is fitted to reach only IP50 protection index. The overall length dimension is with Desmopan bend relief (see pages 91 and 92).



PHG Free receptacle, key (G) or keys (A...F, L and R), cable adapter and nut for fitting a bend relief

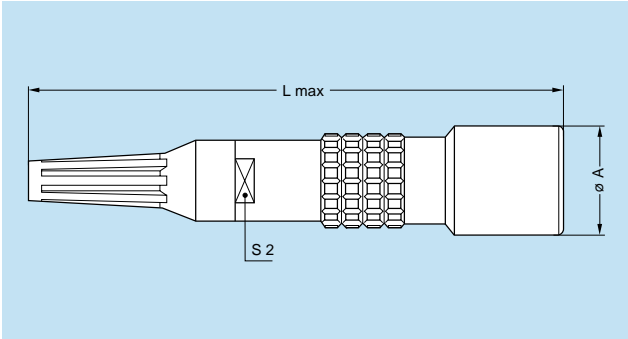

Reference		Dimensions (mm)			Avail-ability
Model	Series	A	L	S2	
PHG	2K	19	103.0	12	○
PHG	3K	23	113.0	15	○
PHG	4K	29	135.5	19	○
PHG	5K	42	164.0	30	○

Note: The overall length dimension is with Desmopan bend relief (see pages 91 and 92).

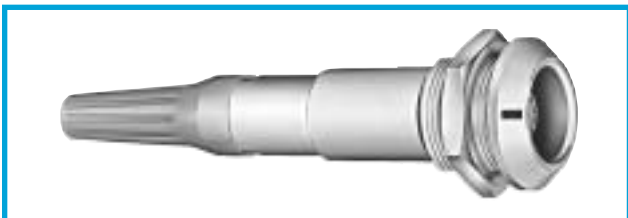

PKG Fixed receptacle, nut fixing, key (G) or keys (A...F, L and R), cable adapter and nut for fitting a bend relief

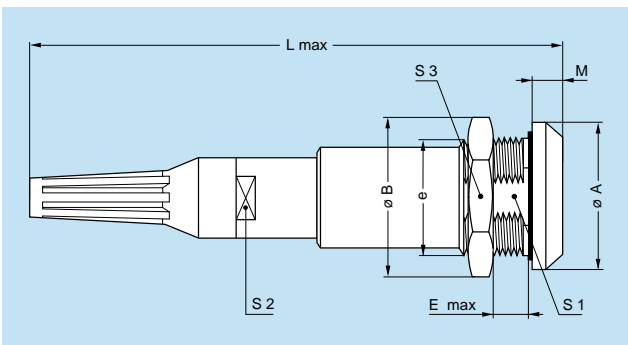

Reference		Dimensions (mm)									Avail-ability
Model	Series	A	B	e	E	L	M	S1	S2	S3	
PKG	2K	25	27.0	M20x1.0	9	103.0	5.0	18.5	12	24	○
PKG	3K	31	34.0	M24x1.0	11	113.0	6.0	22.5	15	30	○
PKG	4K	37	40.5	M30x1.0	9	135.5	6.5	28.5	19	36	○
PKG	5K	55	54.0	M45x1.5	15	164.0	9.0	42.5	30	-	○

Panel cut-out: **P1** (see page 55)

Note: The 5K series is delivered with a round nut (see page 95). The overall length dimension is with Desmopan bend relief (see pages 91 and 92).

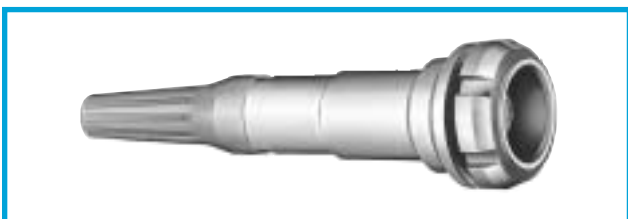

PEG Fixed receptacle, nut fixing, key (G) or keys (A...F, L and R), cable adapter and nut for fitting a bend relief (back panel mounting)

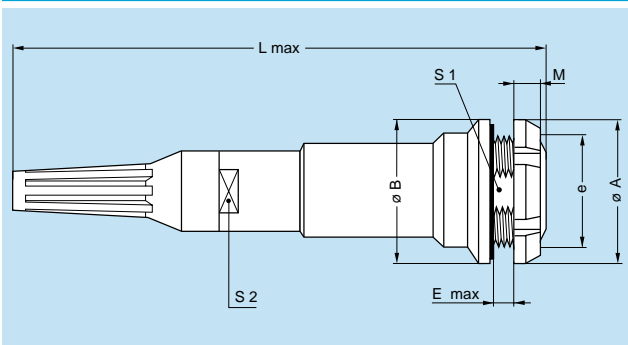

Reference		Dimensions (mm)									Avail-ability
Model	Series	A	B	e	E	L	M	S1	S2		
PEG	2K	25	25	M20x1.0	4.0	103	3.5	18.5	12	○	
PEG	3K	30	31	M24x1.0	7.5	113	4.5	22.5	15	○	
PEG	4K	40.5	35.5	M30x1.0	6.5	75	7.0	13.5	28.5	○	

Panel cut-out: **P1** (see page 55)

Note: The 3K series is delivered with a conical nut (see page 95). The 4K series is delivered with a hex nut (see page 94). The overall length dimension is with Desmopan bend relief (see pages 91 and 92).

● Standard, typically 0-6 weeks delivery for quantities of 250 or less.
 ○ Non-standard product, contact LEMO USA, typically 6-12 weeks delivery for quantities of 250 or less.
 Non-standard product is defined as any product which contains one or more components which are not standard.

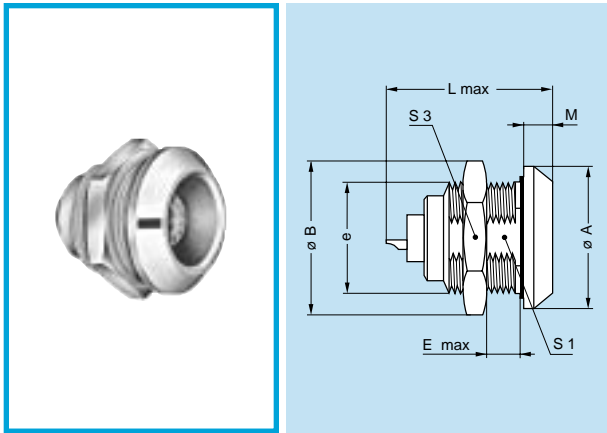

EGG Fixed receptacle, nut fixing, key (G) or keys (A...F, L and R)

Reference		Dimensions (mm)									Availability
Model	Series	A	B	e	E	L max ¹⁾		M	S1	S3	
						F1	F2				
EGG	2K	25	27.0	M20x1.0	9	31.0	41.0	5.0	18.5	24	○
EGG	3K	31	34.0	M24x1.0	11	35.5	42.5	6.0	22.5	30	○
EGG	4K	37	40.5	M30x1.0	9	37.0	41.0	6.5	28.5	36	○
EGG	5K	55	54.0	M45x1.5	10	40.5	42.0	9.0	42.5	-	○

Panel cut-out: **P1** (see page 55)

Note: ¹⁾ The overall length (L) may vary depending upon the type of electrical LV or fiber optic contact fitted. The 5K series is delivered with a round nut (see page 95).

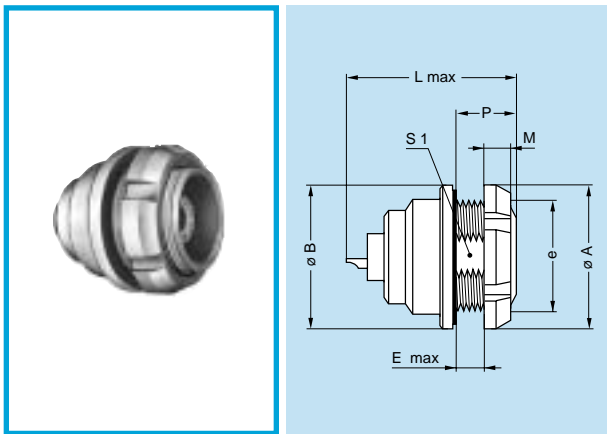

EEG Fixed receptacle, nut fixing, key (G) or keys (A...F, L and R) (back panel mounting)

Reference		Dimensions (mm)									Availability
Model	Series	A	B	e	E	L max ¹⁾		M	P	S1	
						F1	F2				
EEG	2K	25	25	M20x1	5.0	31.0	41.0	3.5	10	18.5	○
EEG	3K	30	31	M24x1	7.5	35.5	42.5	4.5	12	22.5	○

Panel cut-out: **P1** (see page 55)

Note: ¹⁾ The overall length (L) may vary depending upon the type of electrical LV or fiber optic contact fitted. The 3K series is delivered with a conical nut (see page 95).

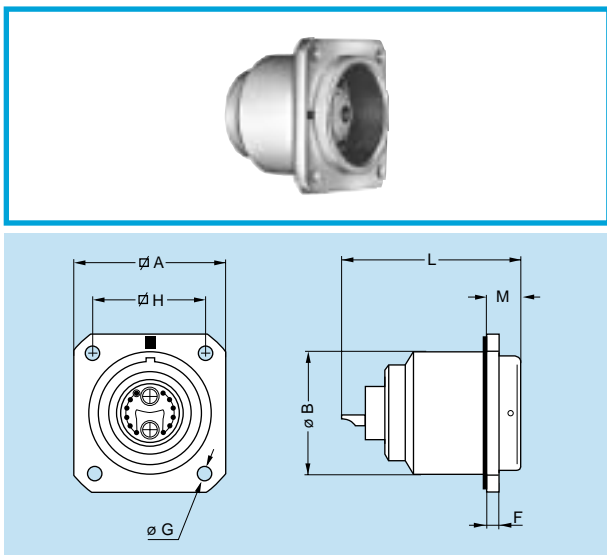

EBG Fixed receptacle with square flange, key (G) or keys (A...F, L and R), four holes fixing

Reference		Dimensions (mm)								Availability
Model	Series	A	B	F	G	H	L max ¹⁾		M	
							F1	F2		
EBG	3K	29	23	3	3.4	23	35.5	42.5	6.0	○
EBG	4K	37	30	3	3.4	29	37.0	41.0	6.5	○

Panel cut-out: **P2** (see page 53)

Note: ¹⁾ The overall length (L) may vary depending upon the type of electrical LV or fiber optic contact fitted.

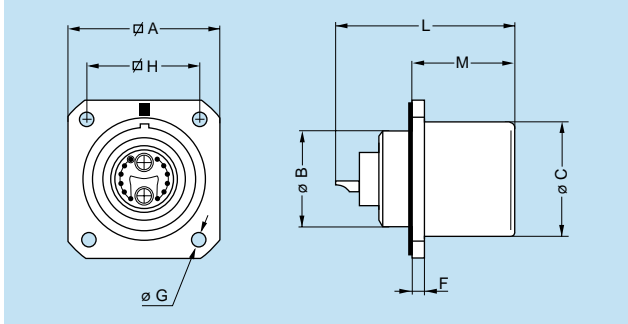
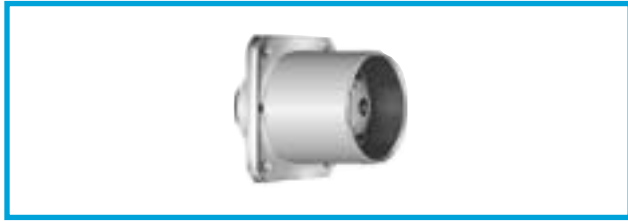

EDG Fixed receptacle with square flange, key (G) or keys (A...F, L and R), protruding shell and earthing tag, screw fixing

Reference		Dimensions (mm)								Avail-ability	
Model	Series	A	B	C	F	G	H	L max ¹⁾			M
								F1	F2		
EDG	3K	29	18	23	3	3.4	23	35.5	42.5	22.5	○

Panel cut-out: **P2** (see page 55)

Note: ¹⁾ The overall length (L) may vary depending upon the type of electrical LV or fiber optic contact fitted.

● **Tooling**

Fiber optic contacts

The full range of tools for terminating fiber optic contacts F1 or F2 used with these 2K-5K series is shown on pages 103 to 106. Consult the factory for the termination instructions.

Electrical contacts

The specific tools that may be used for the termination of crimp LV contacts or the type C coax contacts are shown on pages 100 to 102.

● **Panel Cut-Outs**

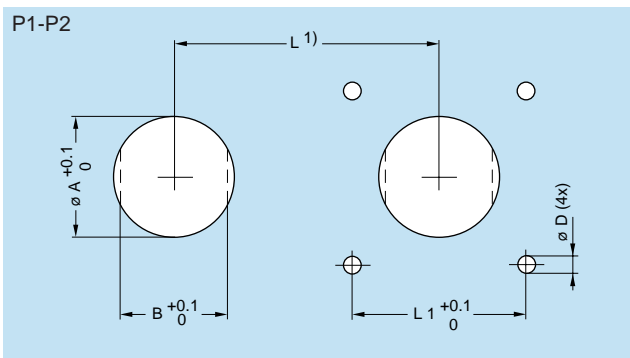

Series	P1			P2			
	ø A	B	L	ø A	D	L	L1
2K	20.2	18.6	29.0	23.2	3.2 or M3	30	23.0
3K	24.2	22.6	35.5	30.2	3.2 or M3	38	29.0
4K	30.2	28.6	43.0	20.2	3.2 or M3	39	20.6
5K	45.2	42.6	57.0	30.2	3.2 or M3	50	29.0

Note: ¹⁾ Minimum distance between two neighboring components.

Mounting torque

Series	Torque (Nm)	
	Nut	Screws
2K	9	–
3K	12	1 to 2 ¹⁾
4K	17	1 to 2 ¹⁾
5K	22	1 to 2 ¹⁾

Note: ¹⁾ Depends on screw material selected. The values shown in the table above are the maximum torque for each connector type. 1N = 0.102 Kg











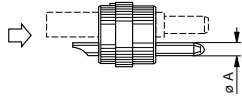
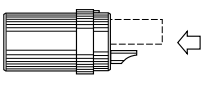
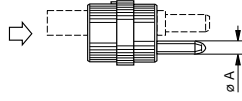























Cut-out types

Model	Type	Model	Type
EBG	P2	FMG	P2
EDG	P2	FXG	P2
EEG	P1	PEG	P1
EGG	P1	PKG	P1

● Standard, typically 0-6 weeks delivery for quantities of 250 or less.
 ○ Non-standard product, contact LEMO USA, typically 6-12 weeks delivery for quantities of 250 or less.
 Non-standard product is defined as any product which contains one or more components which are not standard.

• Types

Multi fiber and Mixed fiber optic (F1 or F2 contact) + LV

		Reference FO Contact Type		Low Voltage contact									
		F1	F2	Fiber optic No	Contact No	ø A (mm)	Contact type availability		Solder contact		Crimp contact		Rated current (A)
							Solder	Crimp	Test voltage (kV rms) ¹⁾ Contact-contact	Test voltage (kV rms) ¹⁾ Contact-shell	Test voltage (kV rms) ¹⁾ Contact-contact	Test voltage (kV rms) ¹⁾ Contact-shell	
 Male solder contacts		 Female solder contacts											
 Male crimp contacts		 Female crimp contacts											
2B 2K			96A 92A	1	2	0.9	○	○	1.75	1.60	1.85	1.60	9.0
			96C 92C	1	4	0.7	○	○	0.85	1.20	0.85	1.25	6.0
			96E 92E	1	6	0.7	○	○	0.85	1.20	0.85	1.25	6.0
			96J 92J	1	10	0.7	○	○	1.15	1.35	1.30	1.05	6.0
3B 3K			07A 03A	2	-	-	-	-	-	-	-	-	-
			97C 93B	2	4	0.9	○	○	1.20	1.05	1.00	0.80	8.0
			97E 93E	2	6	0.9	○	○	1.20	1.05	1.00	0.80	8.0
			97J 93J	2	10	0.7	○	○	0.95	0.75	0.85	0.65	6.0
			97R 93R	2	16	0.7	○	○	0.80	0.70	0.80	0.75	5.5
			96X 92X	1	22	0.7	○	○	0.80	0.70	0.80	0.75	5.0
4B 4K			07C 03C	4	-	-	-	-	-	-	-	-	-
			- 95D	4	5	1.3	○	○	1.20	1.30	1.30	1.05	13
			99H -	4	9	0.7	○	○	1.00	1.00	0.80	0.80	8
			98E 94E	3	6	0.7	○	○	0.90	0.95	0.80	0.80	8
			98L 94L	3	12	0.7	○	○	0.90	0.95	0.80	0.80	6
			- 93E	2	2 4	0.9 1.3	-	○	-	-	1.90 1.85	1.60 2.55	8 12

Note: 1) See calculation method, caution and suggested standard on page 12.

Multi fiber and Mixed fiber optic (F1 or F2 contact) + LV



		Reference FO Contact Type		Low Voltage contact										
				Contact type availability		Solder contact		Crimp contact		Rated current (A)				
				Solder	Crimp	Test voltage (kV rms) ¹⁾ Contact-contact	Test voltage (kV rms) ¹⁾ Contact-shell	Test voltage (kV rms) ¹⁾ Contact-contact	Test voltage (kV rms) ¹⁾ Contact-shell					
F1	F2	Fiber optic No	Contact No	ø A (mm)										
4B 4K			97F	-	2	3 4	0.9 1.3	-	○	-	-	1.15 1.85	1.50 2.55	8 12
			97L	93L	2	12	0.9	○	○	0.95	0.85	0.90	1.20	10
			97R	93R	2	16	0.9	○	○	0.95	0.85	0.85	0.85	10
			97T	93T	2	18	0.7	○	○	0.90	0.95	0.85	0.75	8
5B 5K			07J	03J	10	-	-	-	-	-	-	-	-	-
			-	03N	14	-	-	-	-	-	-	-	-	-
			-	99B	9	1 2	4 2	○	-	2.55 2.55	2.05 2.05	-	-	35 18
			-	94B	3	10	2	○	○	2.10	2.00	2.05	1.75	18

Note: 1) See calculation method, caution and suggested standard on page 12.

Note: The above mentioned multi fiber and mixed fiber optic + LV connectors are delivered **without** fiber optic contacts (See pages 76 and 78 for ordering).

● Standard, typically 0-6 weeks delivery for quantities of 250 or less.
 ○ Non-standard product, contact LEMO USA, typically 6-12 weeks delivery for quantities of 250 or less.
 Non-standard product is defined as any product which contains one or more components which are not standard.

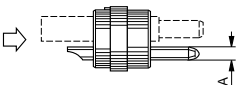
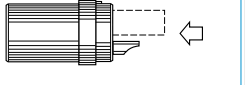

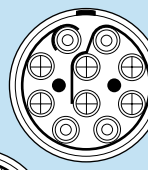
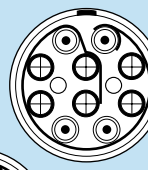
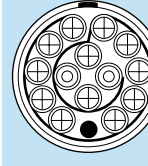
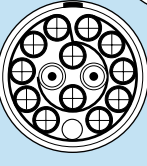



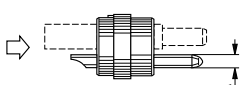
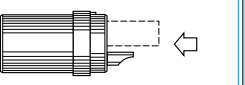

Mixed fiber optic (F2 contact) + HV + LV

	 Male solder contacts		 Female solder contacts		Reference	High Voltage contact							Low Voltage contact				
	Fiber optic F2 No	Contact No	ø A (mm)	Crimp contact type avail.		Crimp contact Test voltage (kV rms) ¹⁾ Contact-contact	Crimp contact Test voltage (kV rms) ¹⁾ Contact-shell	Rated current (A)	Contact No	ø A (mm)	Contact type avail.		Solder/crimp cont.		Rated current (A)		
											Solder	Crimp	Test voltage (kV rms) ¹⁾ Contact-contact	Test voltage (kV rms) ¹⁾ Contact-shell			
3K			93C	2	2	1.3	○	2.25	2.25	10	2	0.9	-	○	1.00	1.00	3
5B 5K			90C	6	4	1.6	○	2.05	1.75	15	2	1.3	○	-	1.85	2.55	8
			956	12	2	1.6	○	2.05	1.75	18	1	2.0	-	○	2.05	1.75	19

Note: 1) See calculation method, caution and suggested standard on page 12.

Note: The above mentioned mixed fiber optic + HV + LV connectors are delivered **without** fiber optic contacts (See page 78 for ordering). More informations about the 3K.93C series are detailed on page 70.

Mixed fiber optic (F2 contact) + coaxial + LV

	 Male solder contacts		 Female solder contacts		Reference	Coaxial contact					Low Voltage contact						
	Fiber optic F2 No	Contact No	Impedance (Ω)	Type		Cable group	Contact No	ø A (mm)	Contact type avail.		Solder contact		Crimp contact		Rated current (A)		
								Solder	Crimp	Test voltage (kV rms) ¹⁾ Contact-contact	Test voltage (kV rms) ¹⁾ Contact-shell	Test voltage (kV rms) ¹⁾ Contact-contact	Test voltage (kV rms) ¹⁾ Contact-shell				
3B 3K			87E	1	1	50	C	1 2 3	6	0.9	○	○	1.30	1.20	0.85	0.95	10
			87R	1	1	50	C	1 2 3	16	0.7	○	○	0.85	0.85	0.60	0.80	6
4B 4K			05C	2	2	50	C	1 2 3	-	-	-	-	-	-	-	-	-
			88E	2	1	50	C	1 2 3	6	0.7	○	○	1.05	1.05	0.80	0.80	3

Note: 1) See calculation method, caution and suggested standard on page 12.

Note: The above mentioned mixed fiber optic + coaxial + LV connectors are delivered **without** coax contacts (See page 59 for ordering). Other configurations are available. All insulators designed for F1 F.O. contacts can accept both F1 F.O. or type C coax contacts.

● Standard, typically 0-6 weeks delivery for quantities of 250 or less.
○ Non-standard product, contact LEMO USA, typically 6-12 weeks delivery for quantities of 250 or less.
Non-standard product is defined as any product which contains one or more components which are not standard.

● Housings

Ref.	Material	Surface treatment		Note
		Outer shell and collet nut	Latch sleeve and grounding crown	
C	Brass	chrome	nickel	■
N	Brass	nickel	nickel	□
K	Brass	black chrome	nickel	■
T	Stainless steel	without treatment	stainless steel	□
L	Aluminum alloy ¹⁾	anodized	nickel-plated brass	□
G	PEEK ²⁾	without treatment	nickel-plated brass	■
P	PSU ³⁾	without treatment	nickel-plated brass	■
R	PPSU ⁴⁾	without treatment	nickel-plated brass	■

Note: Detailed characteristics of these materials and treatments are presented on page 7.

1) The «variant» position of the reference is used to specify the anodized color.

2) Only available for FGG and ENG models of the B series.

3) Only available for ENY and FGY models of the B series. For the color, see the «variant» position.

4) Only available for ENY and FGY models of the B series.

■ First choice alternative □ Special order alternative

● Coaxial Contacts

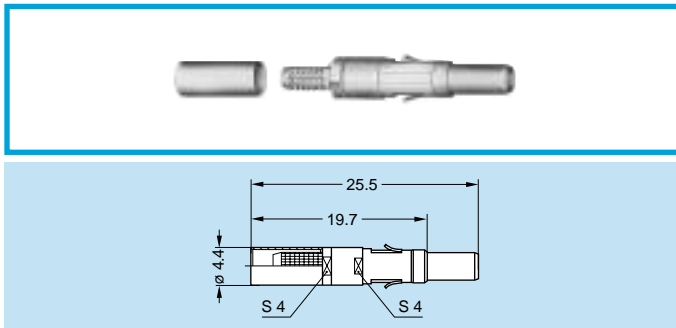

FFS Male coaxial contact type C

Part number	Cable group ¹⁾	Availability
FFS.2B.250.ZTCE24	2	○
FFS.2B.250.ZTCE30	1	○
FFS.2B.250.ZTCE31	3	○

Note: ¹⁾ See page 13 for cable group.

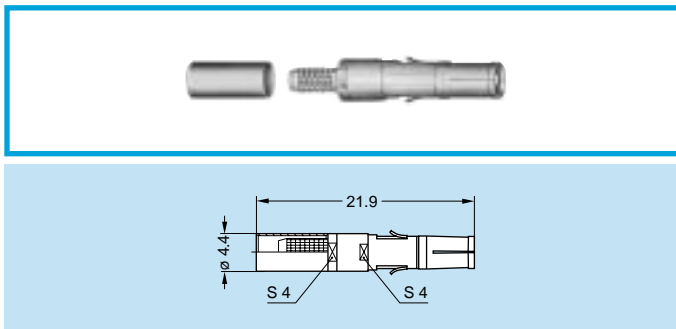

PSS Female coaxial contact type C

Part number	Cable group ¹⁾	Availability
PSS.2B.250.ZTME24	2	○
PSS.2B.250.ZTME30	1	○
PSS.2B.250.ZTME31	3	○

Note: ¹⁾ See page 13 for cable group.

Note: Detailed characteristics of these contacts are presented on page 13.

● Electrical Contacts

Contact for plug, receptacle, and fixed receptacle

Ref.	Contact type
A	male solder
C	male crimp
L	female solder
M	female crimp
Z	no contact

● Collets (B and K Series)

D and M type collets

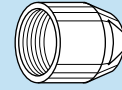
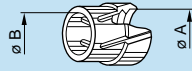

	Reference		Collet \varnothing		Cable \varnothing		Collet part number ¹⁾	Reducer part number ²⁾	Reducing cone part number ²⁾	Collet nut part number	Availability
	Type	\varnothing	$\varnothing A$	$\varnothing B$	max.	min.					
2B	M	21	2.1	–	2.0	1.5	FGG.0B.721.DN	FGG.2B.138.LN	FGG.2B.158.LN	FGG.2B.130.LC	●
	M	31	3.1	–	3.0	2.1	FGG.0B.731.DN	FGG.2B.138.LN	FGG.2B.158.LN	FGG.2B.130.LC	●
	M	42	4.2	–	4.0	3.1	FGG.0B.742.DN	FGG.2B.138.LN	FGG.2B.158.LN	FGG.2B.130.LC	●
	D	52	5.2	–	5.0	4.1	FGG.2B.752.DN	–	–	FGG.2B.130.LC	●
	D	62	6.2	–	6.0	5.1	FGG.2B.762.DN	–	–	FGG.2B.130.LC	●
	D	72	7.2	–	7.0	6.1	FGG.2B.772.DN	–	–	FGG.2B.130.LC	●
	D	82	8.2	–	8.0	7.1	FGG.2B.782.DN	–	–	FGG.2B.130.LC	●
	D	92	9.2	8.6	9.0	8.1	FGG.2B.792.DN	–	–	FGG.2B.130.LC	●
	D	99	9.9	8.6	9.7	9.1	FGG.2B.799.DN ³⁾	–	–	FGG.2B.132.LC	●
3B	M	52	5.2	–	5.0	4.1	FGG.1B.752.DN	FGG.3B.138.LN	FGG.3B.158.LN	FGG.3B.130.LC	●
	D	62	6.2	–	6.0	5.1	FGG.3B.762.DN	–	–	FGG.3B.130.LC	●
	D	72	7.2	–	7.0	6.1	FGG.3B.772.DN	–	–	FGG.3B.130.LC	●
	D	82	8.2	–	8.0	7.1	FGG.3B.782.DN	–	–	FGG.3B.130.LC	●
	D	92	9.2	–	9.0	8.1	FGG.3B.792.DN	–	–	FGG.3B.130.LC	●
	D	10	10.2	–	10.0	9.1	FGG.3B.710.DN	–	–	FGG.3B.130.LC	●
	D	11	11.2	10.2	11.0	10.1	FGG.3B.711.DN	–	–	FGG.3B.130.LC	●
	D	12	11.9	10.2	11.7	11.1	FGG.3B.712.DN ³⁾	–	–	FGG.3B.132.LC	●
4B	M	62	6.2	–	6.0	5.1	FGG.2B.762.DN	FGG.4B.138.LN	FGG.4B.158.LN	FGG.4B.130.LC	○
	M	72	7.2	–	7.0	6.1	FGG.2B.772.DN	FGG.4B.138.LN	FGG.4B.158.LN	FGG.4B.130.LC	○
	M	82	8.2	–	8.0	7.1	FGG.2B.782.DN	FGG.4B.138.LN	FGG.4B.158.LN	FGG.4B.130.LC	○
	M	92	9.2	8.6	9.0	8.1	FGG.2B.792.DN	FGG.4B.138.LN	FGG.4B.158.LN	FGG.4B.130.LC	○
	D	10	10.8	–	10.5	9.1	FGG.4B.710.DN	–	–	FGG.4B.130.LC	○
	D	12	12.3	–	12.0	10.6	FGG.4B.712.DN	–	–	FGG.4B.130.LC	○
	D	13	13.8	12.5	13.5	12.1	FGG.4B.713.DN	–	–	FGG.4B.130.LC	○
	D	15	15.3	12.5	15.0	13.6	FGG.4B.715.DN	–	–	FGG.4B.130.LC	○
	D	16	16.3	12.5	16.0	15.1	FGG.4B.716.DN ³⁾	–	–	FGG.4B.132.LC	○
5B	D	11	11.8	–	11.5	9.6	FGG.5B.711.DN	–	–	FGG.5B.130.LC	○
	D	13	13.8	–	13.5	11.6	FGG.5B.713.DN	–	–	FGG.5B.130.LC	○
	D	15	15.8	–	15.5	13.6	FGG.5B.715.DN	–	–	FGG.5B.130.LC	○
	D	17	17.8	–	17.5	15.6	FGG.5B.717.DN ³⁾	–	–	FGG.5B.130.LC	○
	D	19	19.8	–	19.5	17.6	FGG.5B.719.DN ³⁾	–	–	FGG.5B.130.LC	○
	D	21	21.8	–	21.5	19.6	FGG.5B.721.DN ³⁾	–	–	FGG.5B.130.LC	○
	D	23	23.8	21.8	23.5	21.6	FGG.5B.723.DN ³⁾	–	–	FGG.5B.130.LC	○
	D	25	25.3	21.8	25.0	23.6	FGG.5B.725.DN ³⁾	–	–	FGG.5B.132.LC	○

Note:

- ¹⁾ For ordering collet separately.
- ²⁾ For ordering an M type collet, a reducer and its reducing cone should also be ordered.
- ³⁾ These collets cannot be used for connector models with collet nut for fitting a bend relief.

All dimensions are in millimeters.

Bend relief collet nut and bend relief

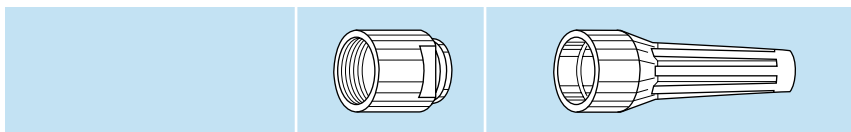

	Reference		Collet nut part number	Bend relief to be used ¹⁾
	Type	ø		
2B	M	21 and 31	FFM.2B.132.LC	GMA.0B.●●●●
	M	42	FFM.2B.130.LC	GMA.2B.●●●●
	D	52 to 92	FFM.2B.130.LC	GMA.2B.●●●●
3B	M	52	FFM.3B.131.LC	GMA.1B.●●●●
	D	62 to 11	FFM.3B.130.LC	GMA.3B.●●●●
4B	M	62 and 72	FFM.4B.132.LC	GMA.2B.●●●●
	M	82 and 92	FFM.4B.130.LC	GMA.4B.●●●●
	D	10 to 15	FFM.4B.130.LC	GMA.4B.●●●●
5B	D	11 to 15	FFM.5B.130.LC	GMA.4B.●●●●

Note: ¹⁾ The bend relief is to be ordered separately (see pages 91 and 92).

All dimensions are in millimeters.

T type cable adapter

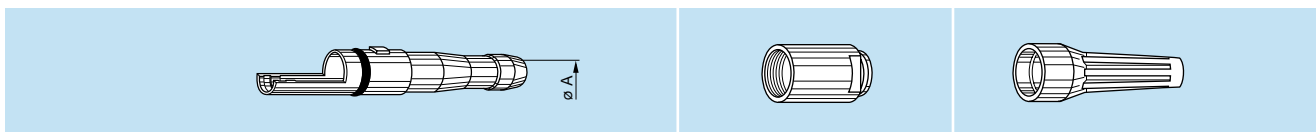

	Reference		Adapter ø A	Cable ø		Adapter with gasket part number	Collet nut part number	Bend relief to be used ¹⁾	Availability
	Type	ø		max.	min.				
2K	T	46	4.6	4.5	3.6	FGG.2K.846.TNV	FFM.2K.130.LC	GMA.2B.040.D●	○
	T	51	5.1	5.0	4.1	FGG.2K.851.TNV	FFM.2K.130.LC	GMA.2B.045.D●	○
	T	56	5.6	5.5	4.6	FGG.2K.856.TNV	FFM.2K.130.LC	GMA.2B.050.D●	○
	T	61	6.1	6.0	5.1	FGG.2K.861.TNV	FFM.2K.130.LC	GMA.2B.057.R●	○
	T	66	6.6	6.5	5.6	FGG.2K.866.TNV	FFM.2K.130.LC	GMA.2B.060.D●	○
3K	T	46	4.6	4.5	3.6	FGG.3K.846.TNV	FFM.3K.134.LC	GMA.2B.040.D●	○
	T	51	5.1	5.0	4.1	FGG.3K.851.TNV	FFM.3K.134.LC	GMA.2B.045.D●	○
	T	56	5.6	5.5	4.6	FGG.3K.856.TNV	FFM.3K.134.LC	GMA.2B.050.D●	○
	T	61	6.1	6.0	5.1	FGG.3K.861.TNV	FFM.3K.134.LC	GMA.2B.057.R●	○
	T	66	6.6	6.5	5.6	FGG.3K.866.TNN	FFM.3K.134.LC	GMA.2B.060.D●	○
	T	71	7.1	7.0	6.1	FGG.3K.871.TNN	FFM.3K.130.LC	GMA.3B.060.D●	○
	T	76	7.6	7.5	6.6	FGG.3K.876.TNN	FFM.3K.130.LC	GMA.3B.070.D●	○
	T	81	8.1	8.0	7.1	FGG.3K.881.TNN	FFM.3K.130.LC	GMA.3B.070.D●	○
	T	86	8.6	8.5	7.6	FGG.3K.886.TNN	FFM.3K.130.LC	GMA.3B.080.D●	○
	T	91	9.1	9.0	8.1	FGG.3K.891.TNN	FFM.3K.130.LC	GMA.3B.080.D●	○
4K	T	46	4.6	4.5	3.6	FGG.4K.846.TNV	FFM.4K.132.LC	GMA.2B.040.D●	○
	T	51	5.1	5.0	4.1	FGG.4K.851.TNV	FFM.4K.132.LC	GMA.2B.045.D●	○
	T	56	5.6	5.5	4.6	FGG.4K.856.TNV	FFM.4K.132.LC	GMA.2B.050.D●	○
	T	61	6.1	6.0	5.1	FGG.4K.861.TNV	FFM.4K.132.LC	GMA.2B.057.R●	○
	T	66	6.6	6.5	5.6	FGG.4K.866.TNV	FFM.4K.132.LC	GMA.2B.060.D●	○
	T	71	7.1	7.0	6.1	FGG.4K.871.TNV	FFM.4K.133.LC	GMA.3B.060.D●	○
	T	76	7.6	7.5	6.6	FGG.4K.876.TNV	FFM.4K.133.LC	GMA.3B.070.D●	○
	T	81	8.1	8.0	7.1	FGG.4K.881.TNV	FFM.4K.133.LC	GMA.3B.070.D●	○
	T	86	8.6	8.5	7.6	FGG.4K.886.TNV	FFM.4K.133.LC	GMA.3B.080.D●	○
	T	91	9.1	9.0	8.1	FGG.4K.891.TNV	FFM.4K.133.LC	GMA.3B.080.D●	○
	T	96	9.6	9.5	8.6	FGG.4K.896.TNV	FFM.3K.132.LC	GMA.4B.010.D● ²⁾	○
	T	10	10.6	10.5	9.6	FGG.4K.810.TNV	FFM.3K.132.LC	GMA.4B.010.D●	○
	T	11	11.6	11.5	10.6	FGG.4K.811.TNV	FFM.3K.132.LC	GMA.4B.011.D●	○
	T	12	12.6	12.5	11.6	FGG.4K.812.TNV	FFM.3K.132.LC	GMA.4B.012.D●	○
T	13	13.6	13.5	12.6	FGG.4K.813.TNV	FFM.3K.132.LC	GMA.4B.013.D●	○	

Note: ¹⁾ The bend relief is to be ordered separately (see pages 91 and 92).
²⁾ Add a short piece of heat-shrink tubing under the bend relief.

● Standard, typically 0-6 weeks delivery for quantities of 250 or less.
 ○ Non-standard product, contact LEMO USA, typically 6-12 weeks delivery for quantities of 250 or less.
 Non-standard product is defined as any product which contains one or more components which are not standard.

T type cable adapter

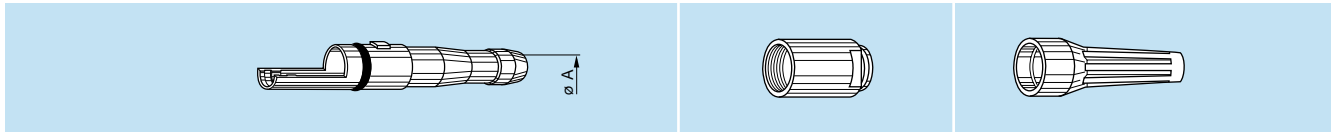

Reference	Adapter		Cable \varnothing		Adapter with gasket part number	Collet nut part number	Bend relief to be used ¹⁾	Availability	
	Type	\varnothing	max.	min.					
5K	T	46	4.6	4.5	3.6	FGG.5K.846.TNV	FFM.5K.132.LC	GMA.2B.040.D●	○
	T	51	5.1	5.0	4.1	FGG.5K.851.TNV	FFM.5K.132.LC	GMA.2B.045.D●	○
	T	56	5.6	5.5	4.6	FGG.5K.856.TNV	FFM.5K.132.LC	GMA.2B.050.D●	○
	T	61	6.1	6.0	5.1	FGG.5K.861.TNV	FFM.5K.132.LC	GMA.2B.057.R●	○
	T	66	6.6	6.5	5.6	FGG.5K.866.TNV	FFM.5K.132.LC	GMA.2B.060.D●	○
	T	71	7.1	7.0	6.1	FGG.5K.871.TNV	FFM.5K.131.LC	GMA.3B.060.D●	○
	T	76	7.6	7.5	6.6	FGG.5K.876.TNV	FFM.5K.131.LC	GMA.3B.070.D●	○
	T	81	8.1	8.0	7.1	FGG.5K.881.TNV	FFM.5K.131.LC	GMA.3B.070.D●	○
	T	86	8.6	8.5	7.6	FGG.5K.886.TNV	FFM.5K.131.LC	GMA.3B.080.D●	○
	T	91	9.1	9.0	8.1	FGG.5K.891.TNV	FFM.5K.131.LC	GMA.3B.080.D●	○
	T	96	9.6	9.5	8.6	FGG.5K.896.TNV	FFM.5K.133.LC	GMA.4B.010.D● ²⁾	○
	T	10	10.6	10.5	9.6	FGG.5K.810.TNV	FFM.5K.133.LC	GMA.4B.010.D●	○
	T	11	11.6	11.5	10.6	FGG.5K.811.TNV	FFM.5K.133.LC	GMA.4B.011.D●	○
	T	12	12.6	12.5	11.6	FGG.5K.812.TNV	FFM.5K.133.LC	GMA.4B.012.D●	○
	T	13	13.6	13.5	12.6	FGG.5K.813.TNV	FFM.5K.133.LC	GMA.4B.013.D●	○
	T	14	14.6	14.5	13.6	FGG.5K.814.TNV	FFM.5K.133.LC	GMA.4B.013.D●	○
	T	15	15.6	15.5	14.6	FGG.5K.815.TNV	FFA.5K.131.LC	heat-shrink tube ³⁾	○
	T	16	16.6	16.5	15.6	FGG.5K.816.TNV	FFA.5K.131.LC	heat-shrink tube	○
	T	17	17.6	17.5	16.6	FGG.5K.817.TNV	FFA.5K.131.LC	heat-shrink tube	○
	T	18	18.6	18.5	17.6	FGG.5K.818.TNV	FFA.5K.134.LC	heat-shrink tube	○
	T	19	19.6	19.5	18.6	FGG.5K.819.TNV	FFA.5K.134.LC	heat-shrink tube	○
	T	20	20.6	20.5	19.6	FGG.5K.820.TNV	FFA.5K.134.LC	heat-shrink tube	○
	T	21	21.6	21.5	20.6	FGG.5K.821.TNV	FFA.5K.132.LC	heat-shrink tube	○
T	22	22.6	22.5	21.6	FGG.5K.822.TNV	FFA.5K.132.LC	heat-shrink tube	○	
T	23	23.6	23.5	22.6	FGG.5K.823.TNV	FFA.5K.132.LC	heat-shrink tube	○	

Note:

¹⁾ The bend relief is to be ordered separately (see pages 91 and 92).

²⁾ Add a short piece of heat-shrink tubing under the bend relief.

³⁾ The heat-shrink tube is supplied.

All dimensions are in millimeters.

● Variant

The «variant» position of the reference is used to specify the color of the shell, the anodized color according to the table below or the cable group.

Color of connectors shell made of plastic material

Ref.	Color
B ¹⁾	white
G ¹⁾	grey

Note: ¹⁾ PSU connector shells are only available in white or grey colors.

Anodized color

Part number for connector with standard collet nut

Ref.	Anodized color	Ref.	Anodized color
A	blue	R	red
J	yellow	T	natural
N	black	V	green

Part number for connector with collet nut for bend relief

Ref.	Anodized color
L	black
X	natural

Note: Other anodizing colors are available for connectors with collet nut for bend relief. Please consult the factory.

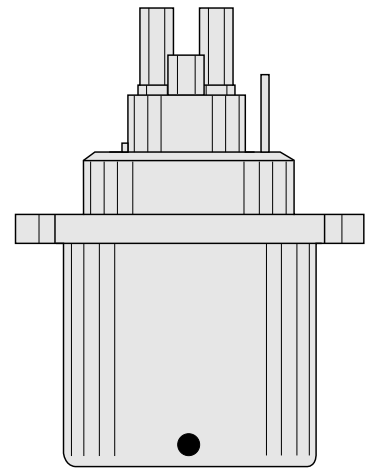

- **3K.93C Series Connectors**

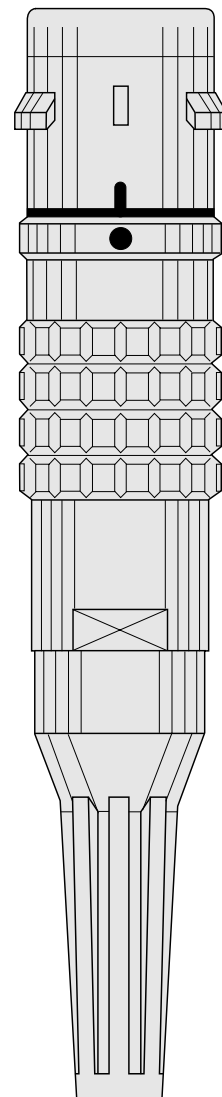

● 3K.93C Series

The LEMO 3K.93C connectors with keys (W) were developed to meet the critical requirements of the new generation of digital HDTV cameras.

The main features of this series are as follows:

- Security of the LEMO self-latching Quick-Lok™ system
- Fitted with the standard LEMO **F2** fiber optic contacts.
- Conforms to the Japanese ARIB technical report BTA S-1005B, to the ANSI/SMPTE 304 M-1998 and 311M-1998 standards and to the European EBU Technical Recommendation R100-1999.
- Qualified for use in UL approved equipment such as those specified in UL 1419 «Professional Video and Audio Equipment».
- Cabled connectors have obtained the EC Attestation of conformity No: N8 00 03 39058 001 from the German TÜV Product Service.

The 3K.93C series consists of eleven models which will accept cables specific to this application. It includes the HEAVY DUTY line with stainless steel shells that is guaranteed to at least 20,000 mating cycles and offerS more resistance to heavy wear conditions.

Interconnections

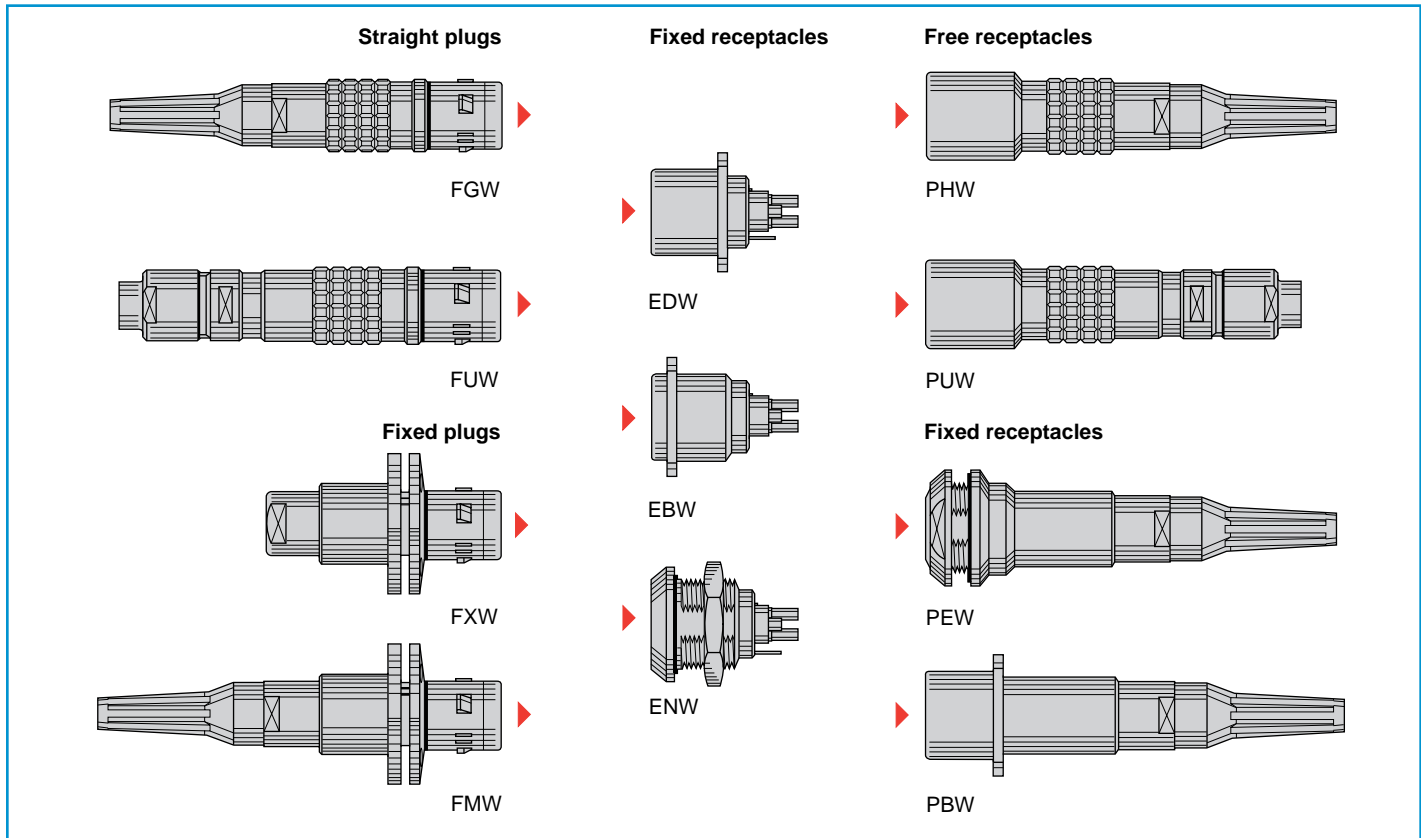

Model Description

- | | | |
|--|--|---|
| <p>FGW Straight plug, keys (W), cable adapter, with bend relief</p> <p>FMW Fixed plug with round flange (4 holes fixing), keys (W), cable adapter, with bend relief</p> <p>FUW Straight plug, keys (W), cable collet adapter and long shell for fitting a bend relief with cap (with enhanced screen efficiency)</p> <p>FXW Fixed plug with round flange (4 holes fixing), keys (W)</p> <p>EBW Fixed receptacle with front square flange (4 holes fixing), keys (W)</p> | <p>EDW Fixed receptacle with rear square flange (4 holes fixing), keys (W), and earthing tag</p> <p>ENW Fixed receptacle, nut fixing, keys (W), and earthing tag</p> <p>PBW Fixed receptacle with rear square flange (4 holes fixing), keys (W), cable adapter, with bend relief</p> <p>PEW Fixed receptacle, nut fixing, keys (W), cable adapter, with bend relief (back panel mounting)</p> <p>PHW Free receptacle, keys (W), cable adapter, with bend relief</p> | <p>PUW Free receptacle, keys (W), cable collet adapter and long shell for fitting a bend relief with cap (with enhanced screen efficiency)</p> |
|--|--|---|

Part Section Showing Internal Components

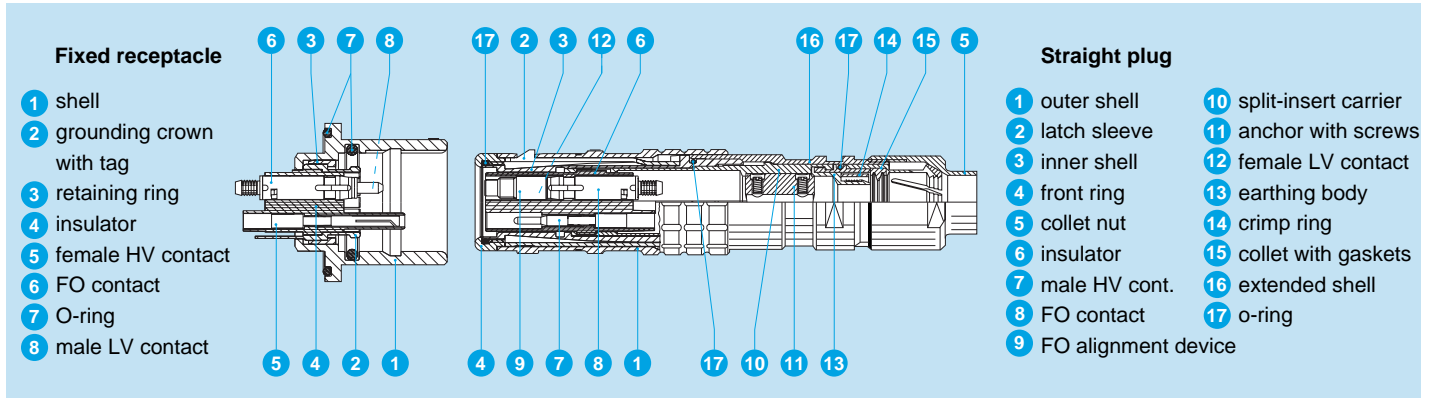

Technical Characteristics

Materials and Treatments

Component	Material (Standard)	Surface treatment (µm)								
		chrome			nickel		gold			
		Cu	Ni	Cr	Cu	Ni	Cu	Ni	Au	
Outer shell, collet nut and oversized collet	Brass (UNS C 38500)	0.5	3	0.3	-	-	-	-	-	
	Stainless steel (AISI 303)	without treatment								
Grounding crown	Special brass	-	-	-	0.5	3	-	-	-	
	Stainless steel (AISI 416)	without treatment								
Latch sleeve	Special brass	0.5	3	0.3	-	-	-	-	-	
	Stainless steel (AISI 416)	without treatment								
Locking washer	Bronze (UNS C 52100)	-	-	-	0.5	3	-	-	-	
Hexagonal or round nut	Brass (UNS C 38500)	-	-	-	0.5	3	-	-	-	
Male crimp contact	Brass (UNS C 34500)	-	-	-	-	-	0.5	3	1.0	
Female crimp contact	Bronze (UNS C 54400)	-	-	-	-	-	0.5	3	1.5	
Clips	Cu-Be (FS QQ-C-530)	without treatment								
Insulator	PEEK	-								
Crimping tube	Copper (UNS C 18700)	-	-	-	0.5	3	-	-	-	
Other metallic components	Brass (UNS C 38500)	-	-	-	0.5	3	-	-	-	
	Stainless steel (AISI 303)	without treatment								
O-ring and gaskets	Silicone MQ/MVQ, FPM/FKM (Viton®) or Nitril NBR	-								

Notes: Standards for surface treatment are as follows:
 - Chrome-plated: FS QQ-C-320B;
 - Nickel-plated: FS QQ-N-290A, or MIL-C-26074C;
 - Gold-plated: ISO 4523

Mechanical and Environmental

Characteristic	Value	Standard
Mating durability (Brass+Brass)	10,000 cycles	IEC 61300-02-02
Mating durability (Brass+Stainless steel)	8,000 cycles	IEC 61300-02-02
Mating durability (Stainless steel+St. steel)	20,000 cycles	IEC 61300-02-02
Damp heat steady state	Up to 95% at 140°F	IEC 61300-02-19
High temperature	+ 176°F	IEC 61300-02-18
Low temperature	-40°F	IEC 61300-02-17
Temperature cycling	-67°F + 194°F	
Cable retention	1000 N	IEC 61300-02-04
Impact (Method A)	2 m onto concrete floor	IEC 61300-02-12
Shock (3 cycles in 2 directions)	100 g, 10-50 ms; 20 g 6-9 ms	IEC 61300-02-09
Vibration (7 cycles)	Diagram 2 page 16	IEC 61300-02-01
Water resistance (Depth of 1.8 for 48 h)	IP 68	IEC 60529
Salt spray corrosion test ¹⁾	> 144h	IEC 60512-6 test 11f

Note: ¹⁾ the outer shells are in chrome-plated brass (Cr1).

Optical

Characteristic	Value	Standard	Method
Average insertion loss fiber 9/125 µm	0.10 dB	IEC 61300-03-04	Insertion Method B
Return loss fiber 9/125 µm (UPC)	≥45 dB	IEC 61300-03-06	Branching Device Met.
Return loss fiber 9/125 µm (Hand polish)	~30 dB	IEC 61300-03-06	Branching Device Met.

Electrical

Characteristic	Value	Standard	Section
Insulation resistance	> 10 ¹² Ω	IEC 60512-2	test 3a
Shell electrical continuity	< 1.6 mΩ	IEC 60512-2	test 2f
Contact resistance (signal)	< 4.8 mΩ	IEC 60512-2	test 2a
Contact resistance (power)	< 3.6 mΩ	IEC 60512-2	test 2a
Radiated emission ¹⁾	freq. 30-220 MHz	< 30 dBµV/m	EN 55022 class B
	freq. 220-1000 MHz	< 37 dBµV/m	EN 55022 class B

Note: ¹⁾ for FUW and PUW model only. Detailed characteristics are presented on inside back cover and pages 15-16.

Alignment Key and Polarized Keying Systems

Front view of a receptacle 	Model	No of keys	Angles	
	••W		5	α
			β	115°
			γ	20°
			δ	30°

Recommended cables

Cable group	Type	Utilisation	Sheath outer ø
1	2SM-8.6-37.5	outdoor	8.6 ± 0.3
2	2SM-9.2-37.5	outdoor	9.2 ± 0.3
3	2SM-12-15	long distances	12.0 ± 0.4
4 ¹⁾	2SM-16-37.5	indoor	16.0 ± 0.5

Note: 1) The outer sheath shall be removed for assembly.

● Part Number Example

A different part number structure is applicable for each of the following product types:

- Plugs and receptacles for assembly onto cables
- Fixed plugs and receptacles.

Straight plug with cable adapter

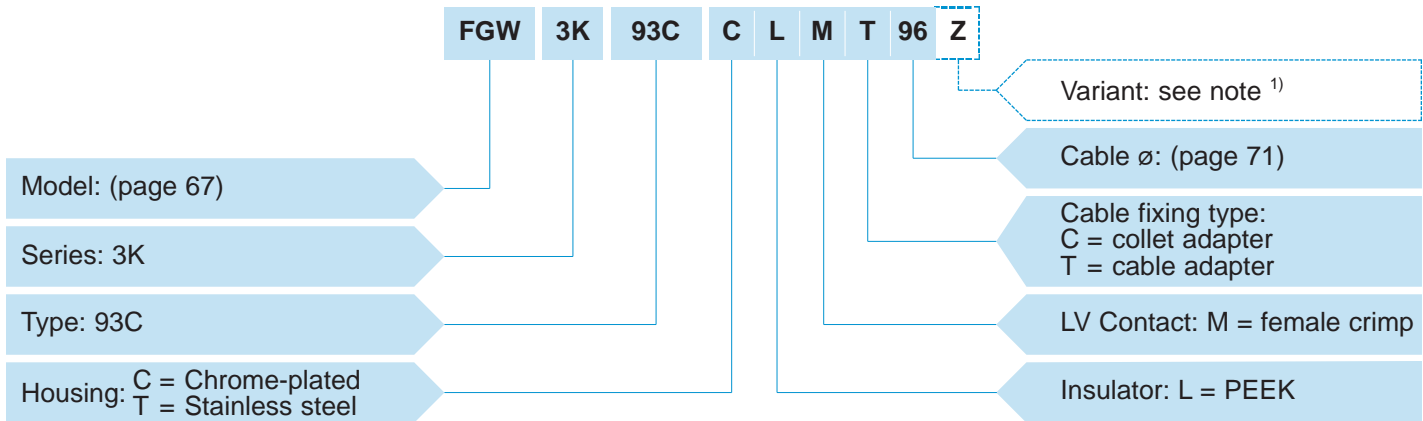

FGW.3K.93C.CLMT96Z = Straight plug with keys (W), 3K series, mixed type to accept 2 F2 type fiber optic contacts, 2 power and 2 signal electrical contacts, chrome-plated brass housing, PEEK insulator, female crimp signal contacts, cable fixing type T for 9.2 mm diameter cable, and nut for fitting a bend relief.

Fixed receptacle

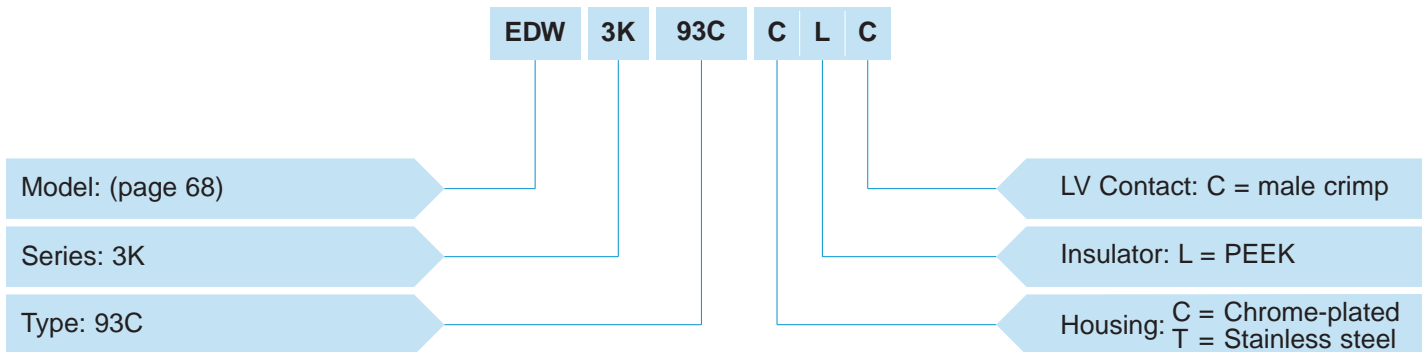

EDW.3K.93C.CLC = Fixed receptacle with rear square flange, keys (W), 3K series, mixed type to accept 2 F2 type fiber optic contacts, 2 power and 2 signal electrical contacts, chrome-plated brass housing, PEEK insulator, male crimp signal contacts.

The fiber optic contacts must be ordered separately (see page 78).

Note: 1) The «Variant» position in the reference is used to indicate the presence of a collet nut for fitting the bend relief. For models with the «T» type of cable adapter the «Z» should always be indicated and a bend relief can be ordered separately as indicated in the «Accessories» section. An order for a connector with bend relief should thus include two part numbers.

● Models

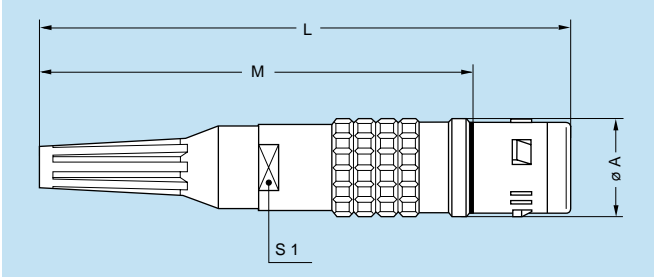
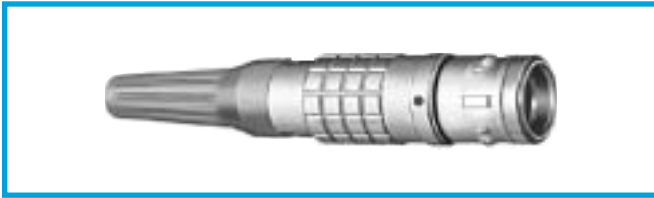

FGW.3K Straight plug, keys (W), cable adapter, with bend relief

Part Number	Cable group	Dimension (mm)				Availability
		A	L	M	S1	
FGW.3K.93C.CLMT90Z	1	19	101	81	15	○
FGW.3K.93C.CLMT96Z	2, 4	19	101	81	15	○
FGW.3K.93C.CLMT12Z	3	19	135	115	20	○

Note: The bend relief must be ordered separately (see page 91). The overall length dimension is with Desmopan bend relief (see pages 91 and 92).

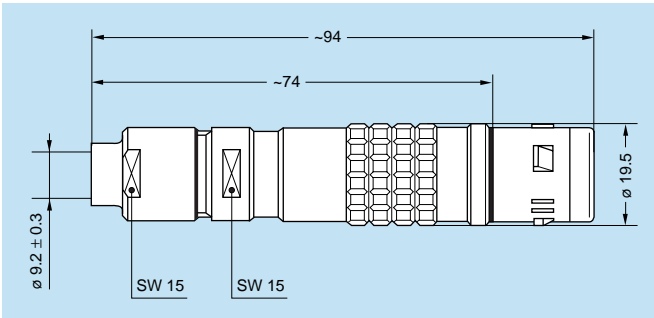
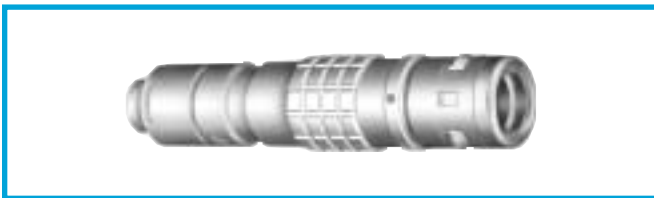

FUW.3K Straight plug, keys (W), cable collet adapter and long shell for fitting a bend relief with cap (with enhanced screen efficiency)

Part Number	Cable group	Note	Availability
FUW.3K.93C.CLMC96	2, 4	–	○
FUW.3K.93C.TLMC96	2, 4	HEAVY DUTY LINE	○

Note: The bend relief with cap must be ordered separately (see page 91).

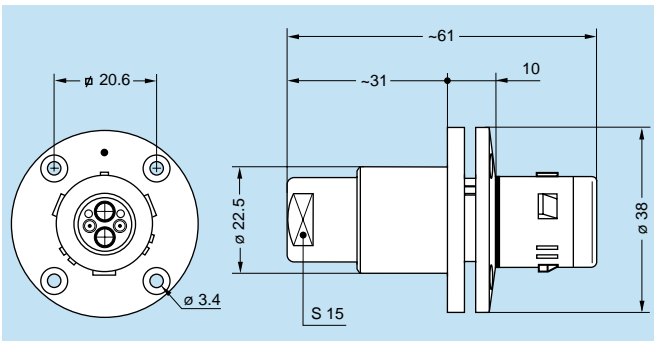
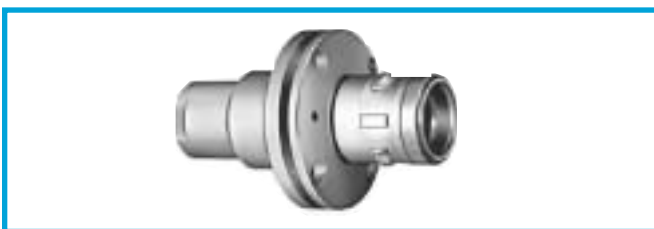

FXW.3K Fixed plug with round flange (4 holes fixing), keys (W)

Part Number	Note	Availability
FXW.3K.93C.CLM	–	○
FXW.3K.93C.TLM	HEAVY DUTY LINE	○

Panel cut-out (page 75)

● Standard, typically 0-6 weeks delivery for quantities of 250 or less.
 ○ Non-standard product, contact LEMO USA, typically 6-12 weeks delivery for quantities of 250 or less.
 Non-standard product is defined as any product which contains one or more components which are not standard.

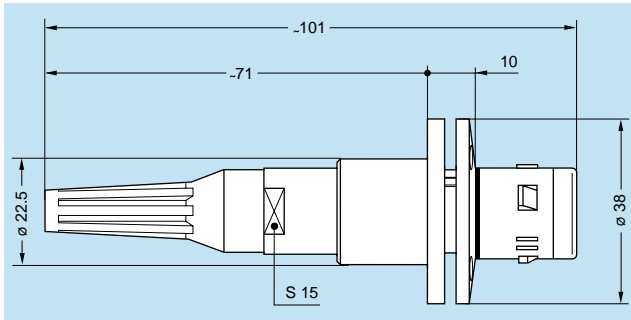
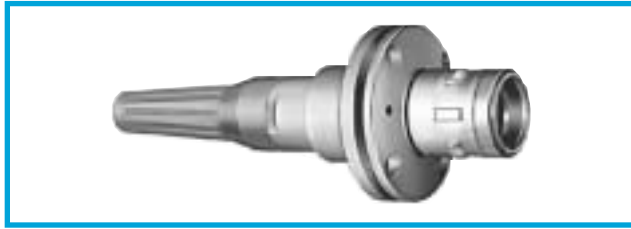

FMW.3K Fixed plug with round flange (4 holes fixing), keys (W), cable adapter, with bend relief

Part Number	Cable group	Note	Availability
FMW.3K.93C.CLMT90Z	1	–	○
FMW.3K.93C.CLMT96Z	2, 4	–	○
FMW.3K.93C.TLMT96Z	2, 4	HEAVY DUTY LINE	○

Panel cut-out (page 75)

Note: See FXW drawing for front view. The bend relief must be ordered separately (see page 91). The overall length dimension is with Desmopan bend relief (see pages 91 and 92).

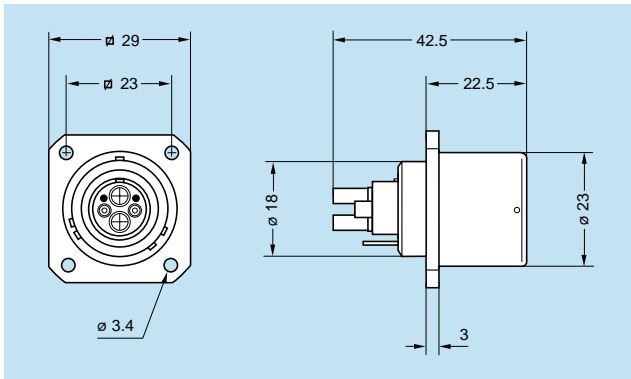

EDW.3K Fixed receptacle with rear square flange (4 holes fixing), keys (W), and earthing tag

Part Number	Note	Availability
EDW.3K.93C.CLC	–	○
EDW.3K.93C.TLC	HEAVY DUTY LINE	○

Panel cut-out (page 75)

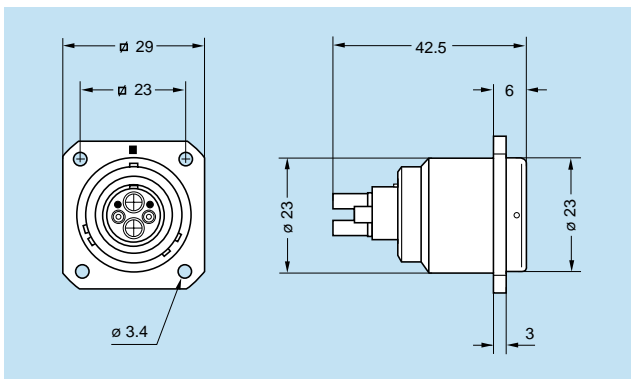

EBW.3K Fixed receptacle with front square flange (4 holes fixing), keys (W)

Part Number	Availability
EBW.3K.93C.CLC	○

Panel cut-out (page 75)

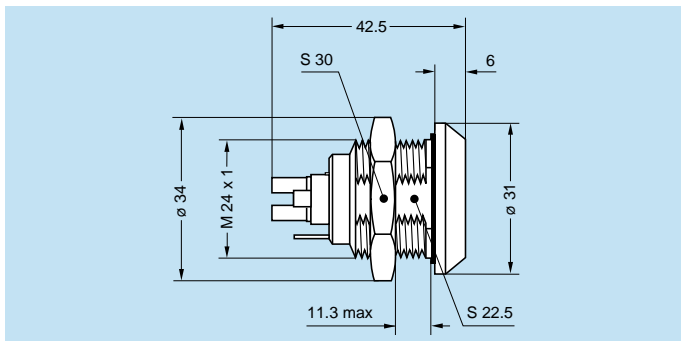

ENW.3K Fixed receptacle, nut fixing, keys (W), and earthing tag

Part Number	Availability
ENW.3K.93C.CLC	○

Panel cut-out (page 75)

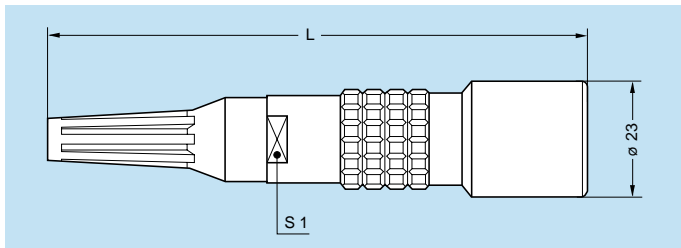
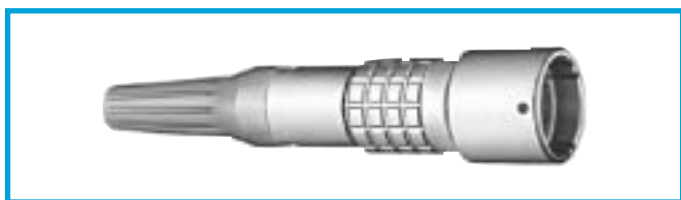

PHW.3K Free receptacle, keys (W), cable adapter, with bend relief

Part Number	Cable group	Dimension (mm)		Availability
		L	S1	
PHW.3K.93C.CLCT90Z	1	105	15	○
PHW.3K.93C.CLCT96Z	2, 4	105	15	○
PHW.3K.93C.CLCT12Z	3	139	20	○

Note: The bend relief must be ordered separately (see page 91). The overall length dimension is with Desmopan bend relief (see pages 91 and 92).

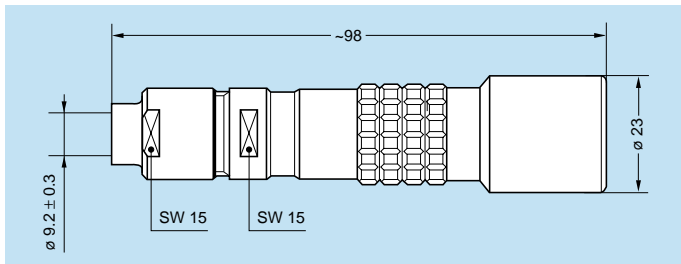
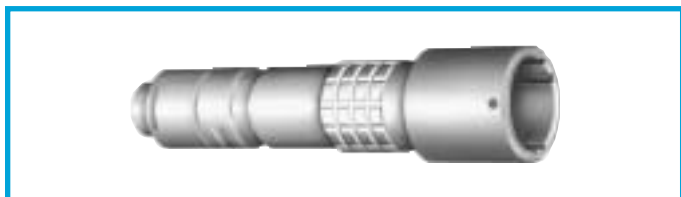

PUW.3K Free receptacle, keys (W), cable collet adapter and long shell for fitting a bend relief with cap (with enhanced screen efficiency)

Part Number	Cable group	Note	Availability
PUW.3K.93C.CLCC96	2, 4	–	○
PUW.3K.93C.TLCC96	2, 4	HEAVY DUTY LINE	○

Note: The bend relief with cap must be ordered separately (see page 91).

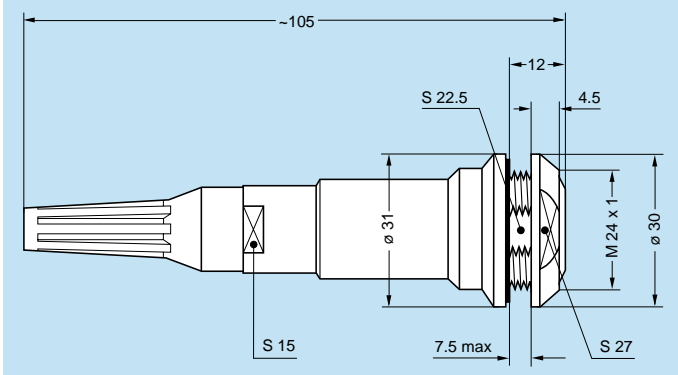
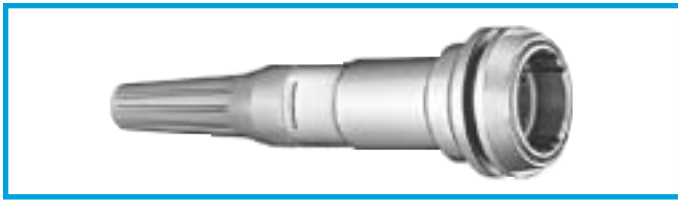

PEW.3K Fixed receptacle, nut fixing, keys (W), cable adapter, with bend relief (back panel mounting)

Part Number	Cable group	Note	Availability
PEW.3K.93C.CLCT90Z	1	-	○
PEW.3K.93C.CLCT96Z	2, 4	-	○
PEW.3K.93C.TLCT96Z	2, 4	HEAVY DUTY LINE	○

Panel cut-out (page 75)

Note: The bend relief must be ordered separately (see page 91). The overall length dimension is with Desmopan bend relief (see pages 91 and 92).

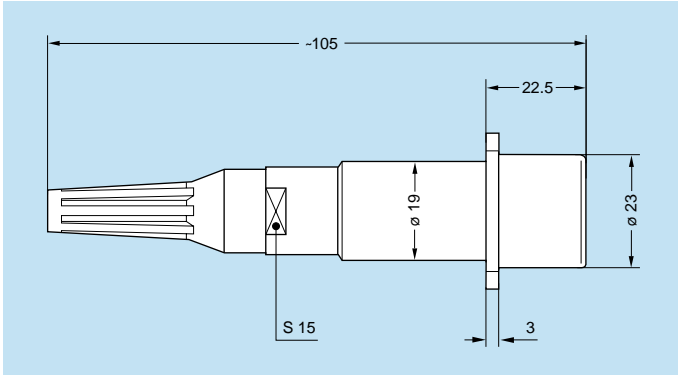
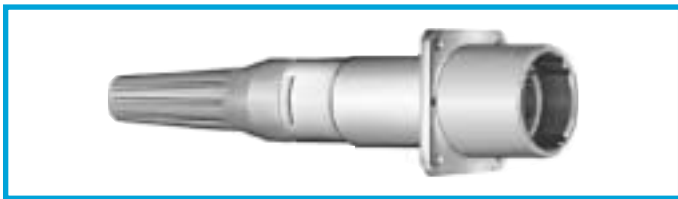

PBW.3K Fixed receptacle with rear square flange (4 holes fixing), keys (W), cable adapter, with bend relief

Part Number	Cable group	Availability
PBW.3K.93C.CLCT90Z	1	○
PBW.3K.93C.CLCT96Z	2, 4	○

Panel cut-out (page 75)

Note: See EDW drawing for front view. The bend relief must be ordered separately (see page 91). The overall length dimension is with Desmopan bend relief (see pages 91 and 92).

● Types

 Receptacle insulator Plug insulator	Reference	Fiber optic contact				Electrical crimp contacts								Availability	
		Fiber optic F2 No	Contact type for plug	Fiber core/cladding (µm)	Ferrule bore inside ø (µm)	No of contacts	Contact function	Contact type for plug	Contact ø A (mm)	AWG range	Creepage distance and air clearance (mm)	Working voltage (V rms)	Test voltage (V rms)		Rated current (A)
	93C	2	fem.	9/125	125	2	signal	L.V. fem.	0.9	20-24	-	≤42	1000	3	○
		2	power	H.V. male	1.3	14-18	>6.5	≤600	2250	10					

● Standard, typically 0-6 weeks delivery for quantities of 250 or less.
 ○ Non-standard product, contact LEMO USA, typically 6-12 weeks delivery for quantities of 250 or less.
 Non-standard product is defined as any product which contains one or more components which are not standard.

● Fiber Optic Contacts

FFS.F2 Male F2 Fiber Optic Contact

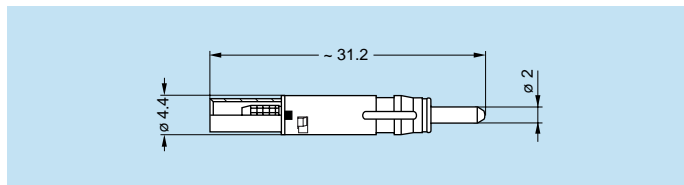
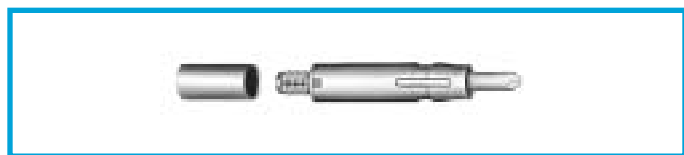

Part number	Models	Availability
FFS.F2.BA2.LCT10	PHW, PEW, PBW, PUW	○
FFS.F2.BA2.LCE30	EDW, ENW, EBW	○

PSS.F2 Female F2 Fiber Optic Contact

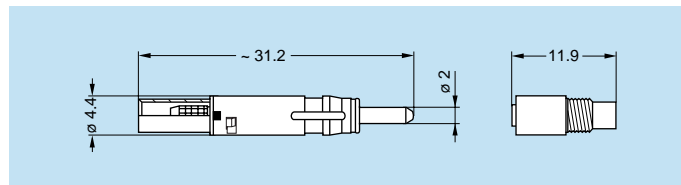
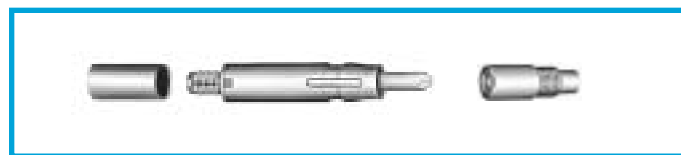

Part number	Models	Availability
PSS.F2.BA2.LCT10	FGW, FMW, FUW	○
PSS.F2.BA2.LCE30	FXW	○

Note: The above contacts are fitted with a 125 micron bore ferrules. If as an alternative 126 micron bore ferrule is required the «BA2» in the part number should be replaced with the reference «BB2».

● Accessories

Cable adapter type «T» for FGW, FMW, PHW, PEW and PBW

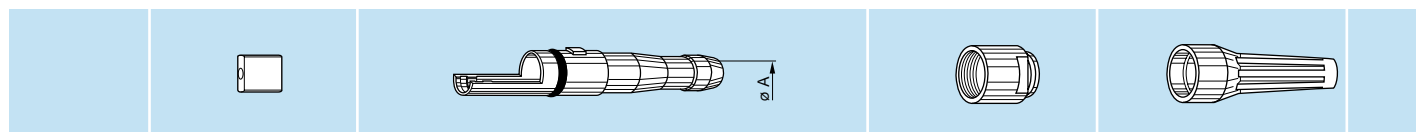

Reference		Part number of the anchor with screws	Adapter ø A	Cable ø		Part number of the adapter with gasket	Part number of the collet nut	Bend relief to be used ¹⁾	Cable group
Type	ø			max.	min.				
T	90	FGW.3K.145.ZZA	9.1	9.0	8.1	FGW.3K.890.TNN	FFM.3E.130.●●	GMA.3B.080.DN	1
T	96	FGW.3K.146.ZZA	9.6	9.5	8.6	FGW.3K.896.TNN	FFM.3K.131.●●	GMA.3B.090.DN	2, 4
T	12	FGW.3K.147.ZZA	12.6	12.5	11.6	FGW.3K.812.TNV	FFM.3K.132.●●	GMA.4B.011.DN	3

Note: ¹⁾ The last letter «N» on the part number indicates black color of the bend relief. For ordering a bend relief with another color see table on page 92 and replace the letter «N» by the letter of the color required.

Collet adapter type «C» for FUW and PUW

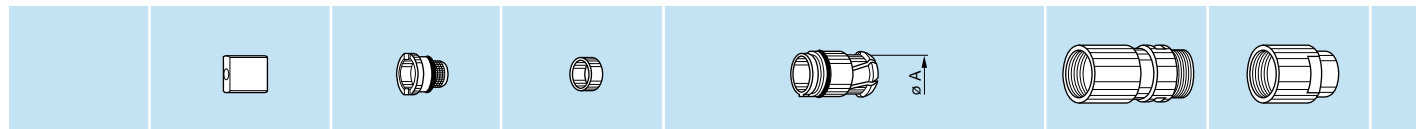

Reference		Part number of the anchor with screws	Part number of earthing body with o-ring	Part number of crimp ring	Collet ø A	Cable ø		Part number of collet with gaskets	Part number of extended shell	Part number of the collet nut	Cable group
Type	ø					max.	min.				
C	96	FGW.3K.146.ZZA	FFS.3K.130.LNV	FFS.3K.160.DN	9.6	9.5	8.6	FUW.3K.796.ZZS	FUW.3K.137.●●	FUW.3K.130.●●	2, 4

Note:
 ●● = LC for chrome-plated brass version
 ●● = AZ for stainless steel version

All dimensions are in millimeters.

Insulator for plug

Part number	Contact type		Availability
	Signal	Power	
EGW.3K.444.EL	Female	Male	○

Note: Insulator should be ordered as replacement item.

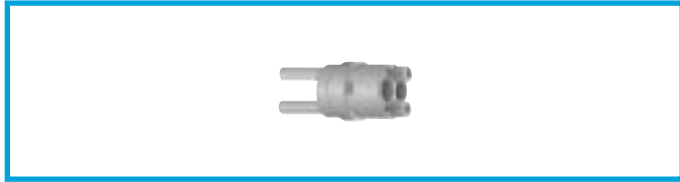
Insulator for receptacle

Part number	Contact type		Availability
	Signal	Power	
FGW.3K.344.EL	Male	Female	○

Note: Insulator should be ordered as replacement item.

Crimp contacts

∅ Contact LV	Contact function	Contact part number		Availability
		Male	Female	
0.9	Signal	FGG.3B.560.ZZC	EGG.3B.660.ZZM	○
1.3	Power 1)	FGW.3K.565.ZZC	EGW.3K.666.ZZM	○

Note: 1) Power contacts are special with an oversized crimp barrel. Crimp contacts should be ordered as replacement items.

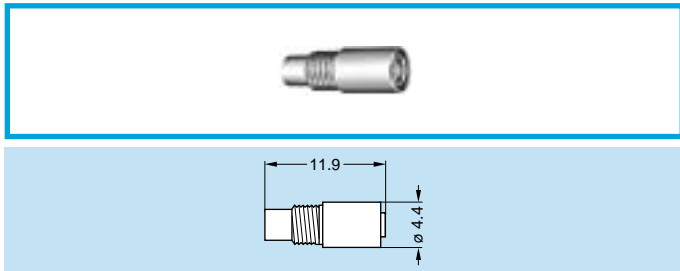
PSS Alignment device for F2 fiber optic contacts

Part number	Availability
PSS.F2.290.NZZ	○

Note: Alignment device should be ordered as replacement item.

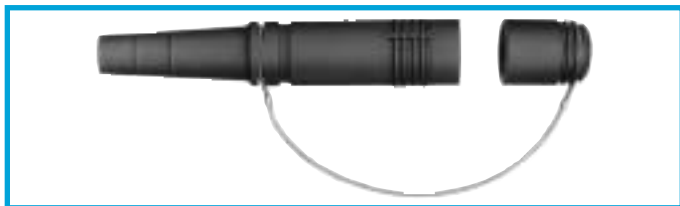
GMF.3K Bend relief with cap for FUW plug

Part number	Availability
GMF.3K.085.EANZ	○

● Material: black EPDM

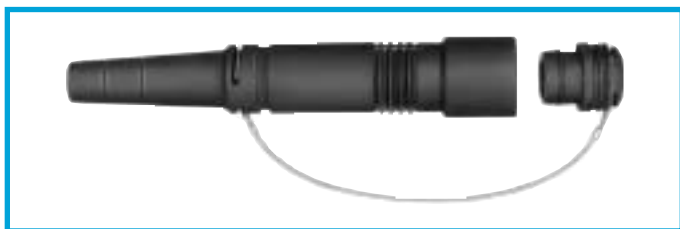
GMP.3K Bend relief with cap for PUW free receptacle

Part number	Availability
GMP.3K.085.EANZ	○

● Material: black EPDM

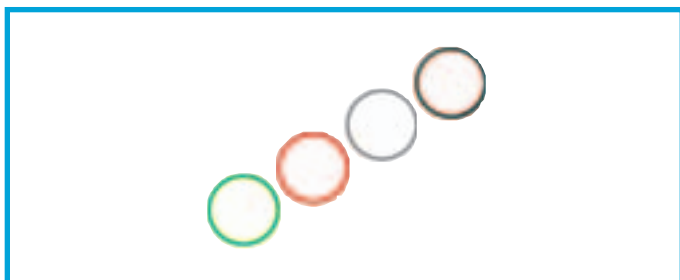

GMF.3K Colored ring for bend relief with cap

Part number	Color	Availability
GMF.3K.265.RG	grey	○
GMF.3K.265.RN	black	○
GMF.3K.265.RR	red	○
GMF.3K.265.RV	green	○

● Material: Silicone

● Standard, typically 0-6 weeks delivery for quantities of 250 or less.
 ○ Non-standard product, contact LEMO USA, typically 6-12 weeks delivery for quantities of 250 or less.
 Non-standard product is defined as any product which contains one or more components which are not standard.

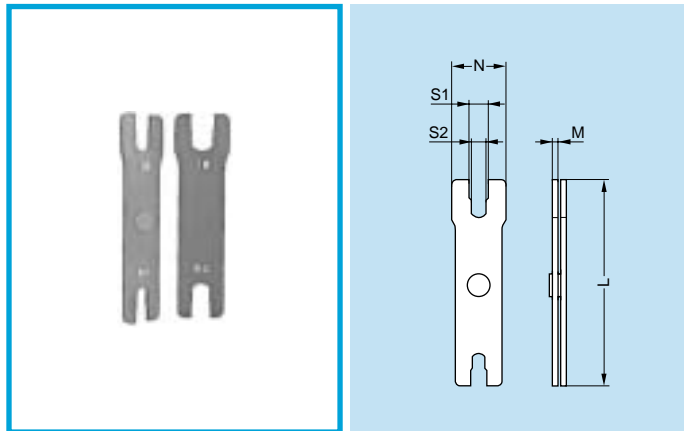
● Tooling



DCP Wrench for tightening collet nut

Part number	Series	Dimensions (mm)				
		L	M	N	S1	S2
DCP.91.023.TN	2K	115	3.0	30	13.1	12.1
	3K	115	3.0	35	15.1	14.1

● Material: Blackened steel



DPF Pliers for assembling plugs or free receptacles

Part number	Dimensions (mm)	
	A	B
DPF.91.033.TA	18	23
Model	plugs	free receptacles

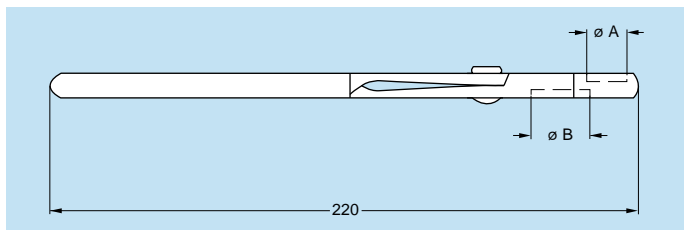

Example for use

The plug or receptacle end must be held in the pliers while the nut is tightened with the wrench.

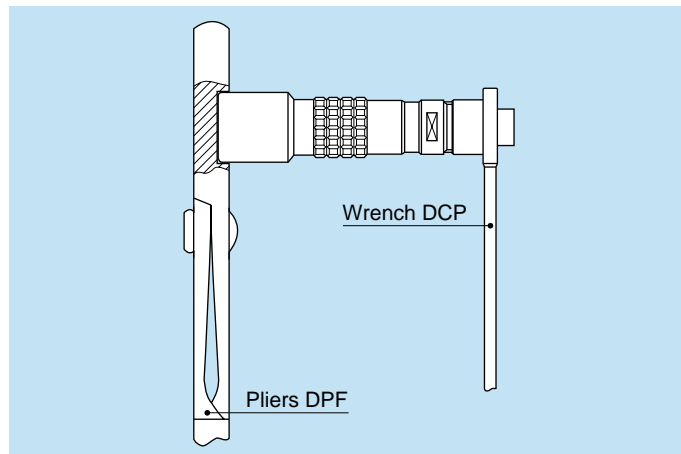
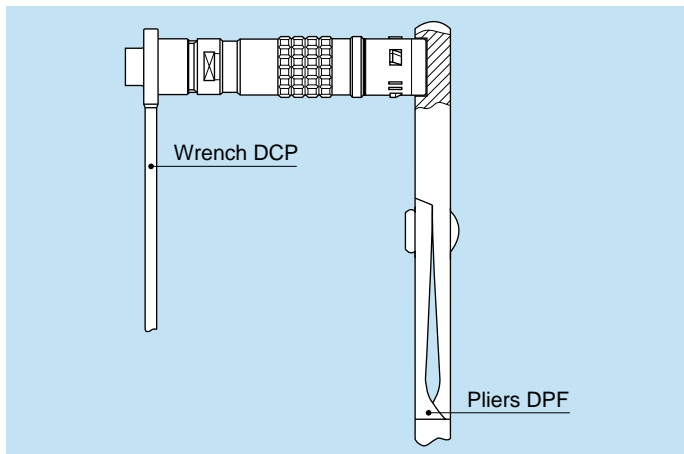

DPD Crimping tool for screen crimping on FUW and PUW

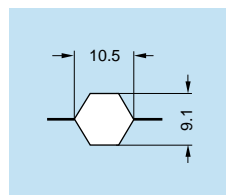

Part number
DPD.99.010.5K

● Fiber Optic Tooling

The full range of tools for terminating fiber optic contacts is shown on pages 103 to 106.

● Crimping Tools for Electrical Contacts

Manual crimping tools

Supplier	Part number	
	signal contacts ø 0.9	power contacts ø 1.3
LEMO	DPC.91.701.V ¹⁾	DPC.91.101.A ²⁾
DANIELS	MH860 ¹⁾	AF8 ²⁾
BALMAR	23-000	55-000
BUCHANAN	616336 ¹⁾	615708 ²⁾

1) According to specification MIL-C-22520/7-01.

2) According to specification MIL-C-22520/1-01.

DCE Positioners for signal contacts ø 0.9 mm

Contacts dimensions		Conductor AWG	Selector Pos.	Positioners part number	
				For male contact	For female contact
ø A	ø C	20-22-24	6-5-5	DCE.91.093.BVC	DCE.91.093.BVM

Note: These positioners are suitable for use with both manual and pneumatic crimping tools according to the MIL-C-22520/7-01 standard.

DCE Turret for power contacts ø 1.3 mm

Power contacts are special with an oversized crimp barrel.

Contacts dimensions		Conductor AWG	Selector Pos.	Positioners part number
				For male and female contact
ø A	ø C	14-16-18	7-6-5	DCE.91.133.BVCW

Note: These turrets can be used with manual crimping tool according to MIL-C-22520/1-01 standard.

Fig. 1



Fig. 2



male



female

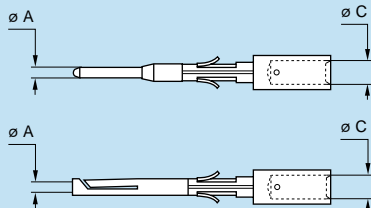
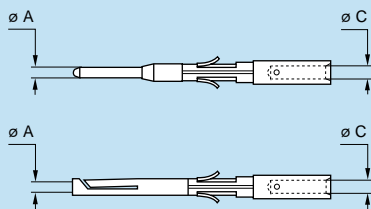

● Termination Instructions



Part Number	Models
DOC.FO.W3K.93CO	All

● Panel Cut-Outs

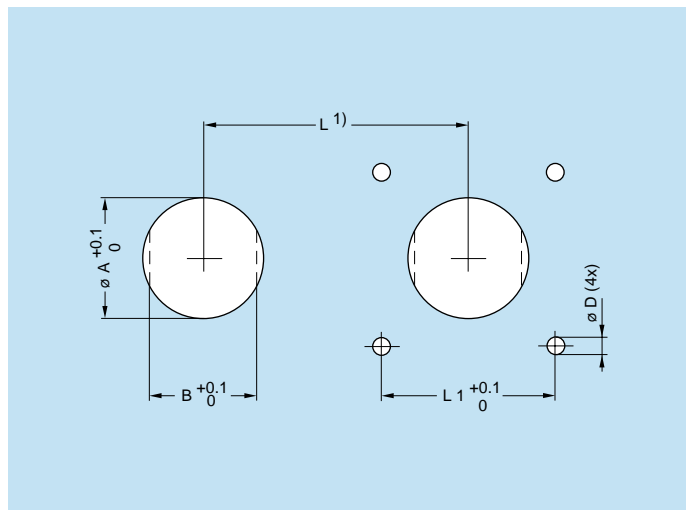

Models	Dimension (mm)				
	A	B	D	L	L1
FMW, FXW	23.2	–	3.2 or M3	39	20.6
EBW	23.2	–	3.2 or M3	30	23.0
EDW	23.2	–	3.2 or M3	30	23.0
ENW, PEW	24.2	22.6	–	32	–
PBW	23.2	–	3.2 or M3	30	23.0

Note: ¹⁾ Minimum distance between two neighboring components.

Mounting torque

Series	Torque (Nm)	
	Nut	Screws
3K	12	1 to 2 ¹⁾

Note: ¹⁾ Depends on screw material selected. The values shown in the table above are the maximum torque for each connector type. 1N = 0.102 Kg

● F1 Fiber Optic Contact

Introduction

The F1 type contact is designed for fitting into multi fiber or mixed fiber optical/electrical connectors from the 2B to 5B, 2K to 5K series.

Its main features are as follows:

- Simple and proven construction with a metallic or ceramic ferrule
 - Polishing with specific tooling ensuring a minimum gap between fibers which are not in physical contact
 - After mounting on the cable, the contact is installed in the main connector insulator, and retained with a metallic clip.
- This contact is suitable for use with multi-mode fibers in Si/Si or plastic, ranging in sizes from 100/140 to 1500 μm .

Part Section Showing Internal Components

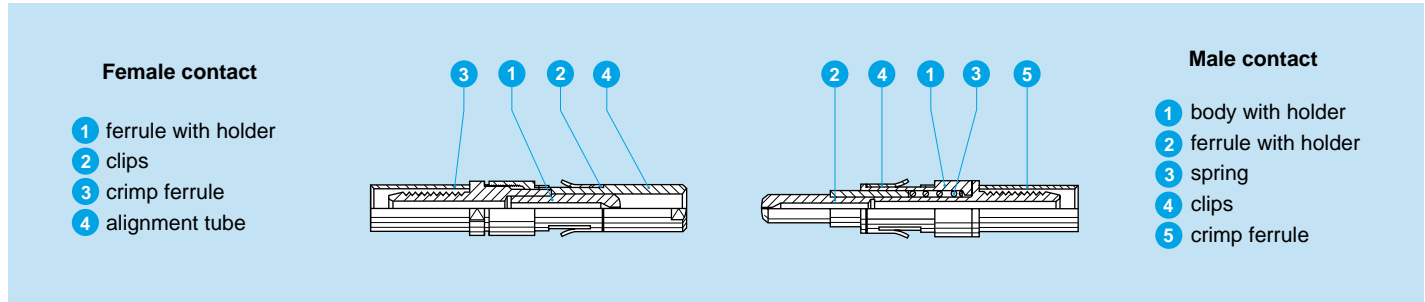

Technical Characteristics

Material and treatment of the Fiber Optic Contact

Component	Material	Surface treatment (μm)	
		Cu	Ni
Body and holder	Alloy CuNiZn	without treatment	
Ferrule	Alloy CuNiZn or ceramic	without treatment	
Spring	Stainless steel	without treatment	
Clip	Cu-Be	without treatment	
Crimp ferrule	Cu 99	0.5	3
Alignment tube	Alloy CuNiZn	without treatment	

Mechanical and Environmental

Characteristic	Value	Standard
Mating durability	1000 cycles	IEC 61300-02-02
Damp heat steady state	up to 95 % at 140°F	IEC 61300-02-19
High temperature	+176°F	IEC 61300-02-18
Low temperature	-40°F	IEC 61300-02-17
Cable retention	100 N	IEC 61300-02-04

Optical

Characteristic	Value	Standard	Method
Average insertion loss fiber 200/230 μm	1.13 dB	IEC 61300-03-04	Insertion Method B

Note: Detailed characteristics are presented on inside back cover and pages 15-16.

Part Number Example

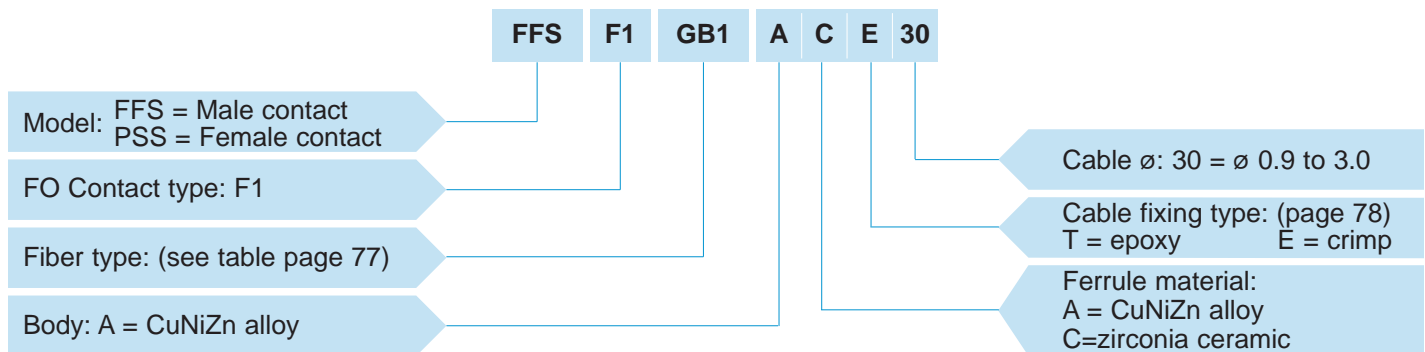

FFS.F1.GB1.ACE30 = Male F1 type fiber optic contact, ferrule bore diameter of 235 μm , ferrule made of zirconia ceramic, crimp type cable fixing for a cable diameter of 0.9 mm to 3.0 mm.

● Model-FO Contact Type

FFS.F1 Male F1 Fiber Optic Contact

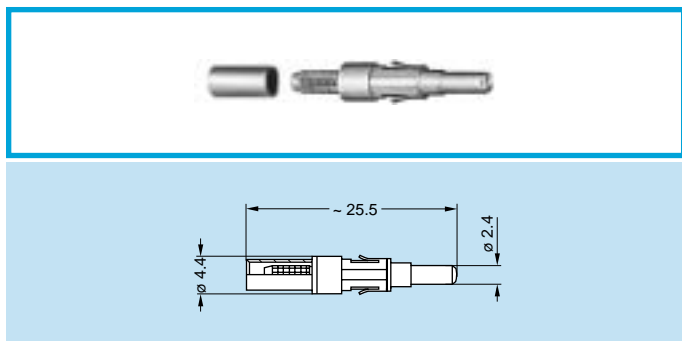

PSS.F1 Female F1 Fiber Optic Contact

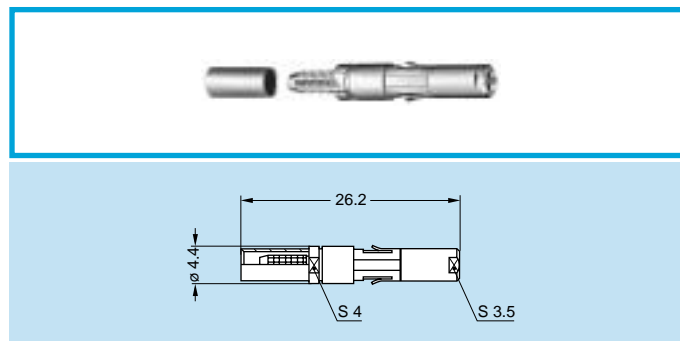

● Fiber Type

The choice of the ferrule hole diameter is dependent upon the fiber cladding size. LEMO offers a range of ferrule hole diameters to suit the users' specific requirements.

Reference	Core/cladding \varnothing (μm)	Ferrule hole \varnothing (μm)	Ferrule material	Material ref.	Fiber type	Cable fixing type	Note
FB1	100/140	144	Ceramic	C	Silica	E	■
GA1	200/230	230	Ceramic	C	HCS	E	□
GB1	200/230	235	Ceramic	C	HCS	E	■
HA1	300/330	330	Ceramic	C	HCS	E	□
HB1	300/330	335	Ceramic	C	HCS	E	■
JA1	400/430	430	Metal	A	HCS	E	□
JB1	400/430	435	Metal	A	HCS	E	■
KA1	600/630	630	Metal	A	HCS	E	□
KB1	600/630	640	Metal	A	HCS	E	■
LA1	800/830	830	Metal	A	HCS	E	□
LB1	800/830	845	Metal	A	HCS	E	■
MA1	1000/1035	1035	Metal	A	HCS	E	□
MB1	1000/1035	1050	Metal	A	HCS	E	■
NA1	500	500	Metal	A	Polymer	E	□
NB1	500	550	Metal	A	Polymer	E	■
PA1	750	750	Metal	A	Polymer	E	□
PB1	750	825	Metal	A	Polymer	E	■
RA1	1000	1000	Metal	A	Polymer	E	□
RB1	1000	1100	Metal	A	Polymer	E	■
RK1	1400	1430	Metal	A	Polymer	E	■
SA1	1500	1500	Metal	A	Polymer	T	□
SB1	1500	1650	Metal	A	Polymer	T	■
TA1	200/380	380	Metal	A	PCS	E	□
TB1	200/380	410	Metal	A	PCS	E	■
VA1	300/440	440	Metal	A	PCS	E	□
VB1	300/440	475	Metal	A	PCS	E	■
WA1	600/750	750	Metal	A	PCS	E	■
WB1	600/750	810	Metal	A	PCS	E	■

■ First choice alternative
□ Special order alternative

● F2 Fiber Optic Contact

Introduction

The F2 type contact is designed for fitting into single fiber OK series, multi fiber connectors or mixed fiber optical/electrical connectors from 2B to 5B, 2K to 5K series.

Its main features are as follows:

- Assembly uses pre-domed ceramic ferrules
- Simple and fast polishing ensuring the physical contact of the fiber end face
- After mounting on the cable, the contact is very easily installed in the main connector insulator, the particular shape of the contact body retains it in the insulator
- Unique cable assembly independent of the connector shell
- The alignment tube can be easily removed in order to clean the fiber end face.

This contact makes it possible to use single fiber cables with single-mode or multi-mode fibers of the following sizes; 9/125, 50/125, 62.5/125, 100/125 and 100/140 μm .

Part Section Showing Internal Components

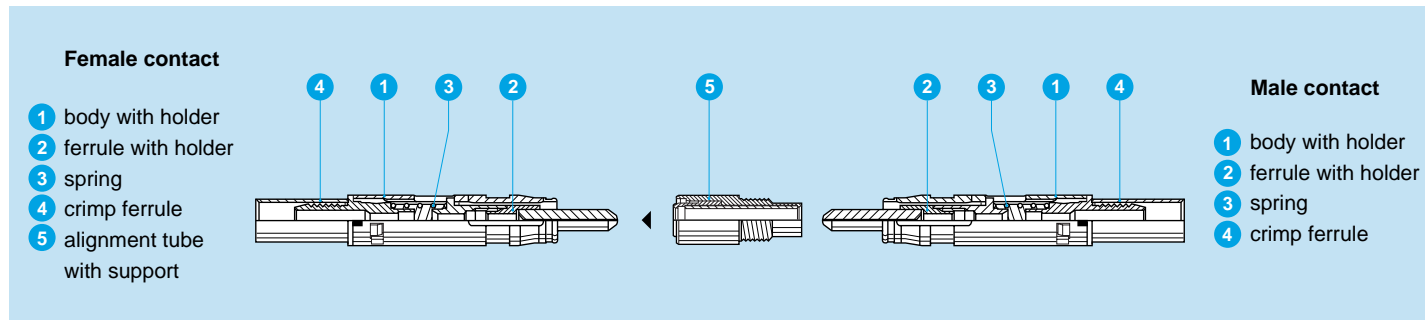

Technical Characteristics

Material and Treatment

Component	Material	Surface treatment (μm)	
		Cu	Ni
Body	PEEK	without treatment	
Ferrule	Ceramic	without treatment	
Holder	Alloy CuNiZn	without treatment	
Crimp holder	Brass	0.5	3
Spring	Stainless steel	without treatment	
Crimp ferrule	Cu 99	0.5	3
Support	Alloy CuNiZn	without treatment	
Alignment tube	Ceramic	without treatment	

Optical

Characteristic	Value	Standard	Method
Average insertion loss fiber 9/125 μm	0.10 dB	IEC 61300-03-04	Insertion Method B
Average insertion loss fiber 50/125 μm	0.25 dB	IEC 61300-03-04	Insertion Method B
Return loss fiber 9/125 μm (UPC)	≥ 45 dB	IEC 61300-03-06	Branching Device Met.
Return loss fiber 9/125 μm (Hand polish)	~ 30 dB	IEC 61300-03-06	Branching Device Met.

Note: Detailed characteristics are presented on pages 109 to 111.

Mechanical and Environmental

Characteristic	Value	Standard
Mating durability	10,000 cycles	IEC 61300-02-02
Damp heat steady state	up to 95 % at 140°F	IEC 61300-02-19
High temperature	+176°F	IEC 61300-02-18
Low temperature	-40°F	IEC 61300-02-17
Cable retention	100 N	IEC 61300-02-04
Impact (Method A)	1 m onto concrete floor	IEC 61300-02-12
Shock (3 cycles in 2 directions)	100 g, 10-50 ms; 20 g 6-9 ms	IEC 61300-02-09
Vibration (7 cycles)	Diagram 2 page 16	IEC 61300-02-01

● Part Number Example

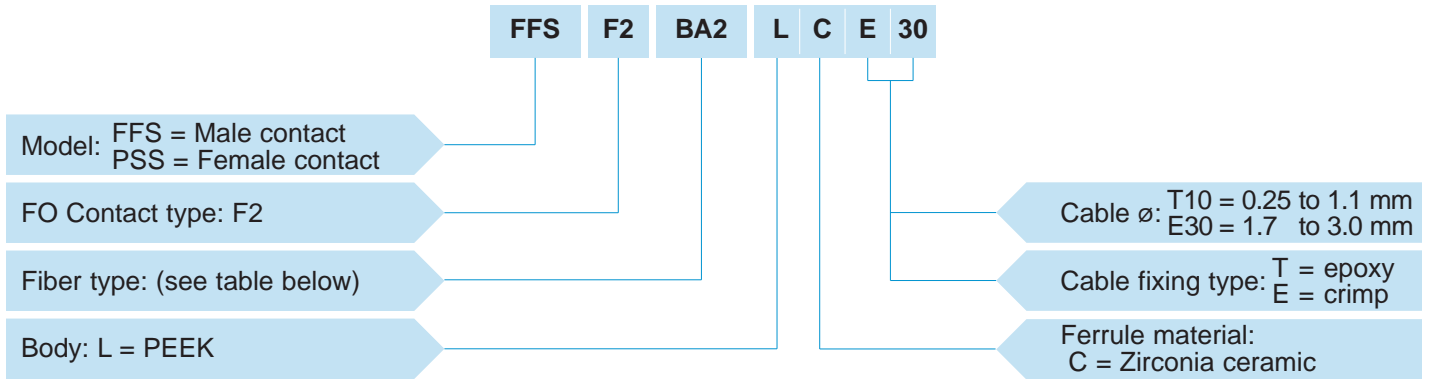

FFS.F2.BA2.LCE30 = Male F2 type fiber optic contact, ferrule bore diameter of 125 µm, PEEK body, Zirconia ceramic ferrule, crimp cable fixing, for tight jacket cable with a diameter between 1.7 to 3.0 mm.

● Model-FO Contact Type

FFS.F2 Male F2 Fiber Optic Contact

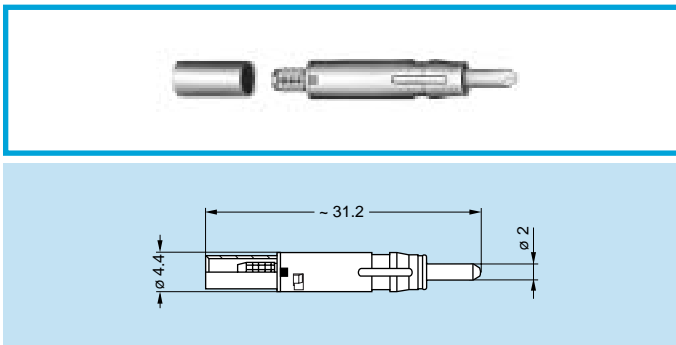

PSS.F2 Female F2 Fiber Optic Contact

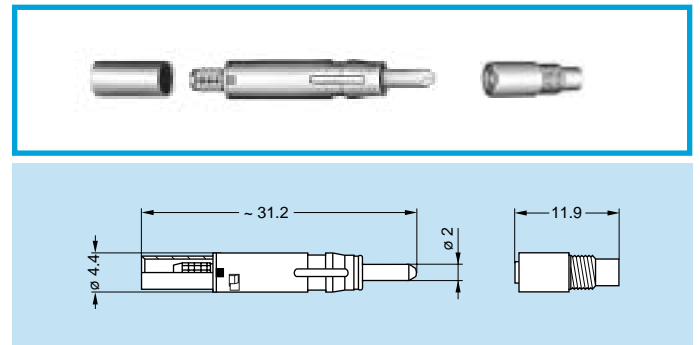

● Fiber Type

The choice of the ferrule hole diameter is dependent upon the fiber cladding size. LEMO offers a range of ferrule hole diameters to suit the users' specific requirements.

Reference	ø Core/Cladding (µm)	Ferrule hole diameter (µm)	Note 1)
BA2	9/125	125	■
BB2	50/125	126	■
BC2	62.5/125	127	□
BD2	100/125	128	□
FA2	100/140	140	□
FB2	100/140	144	■

■ First choice alternative □ Special order alternative

Note: 1) The BA2 type (ferrule hole 125 µm) is recommended for single-mode fibers. The BB2 type (ferrule hole 126 µm) is commonly used with multi-mode fibers.

● Cable Fixing Type

Reference		Cable Structure	Cable ø
Cable fixing	Reference ø		
T	10	Buffer coated fiber	0.25 to 1.1
E	30	Tight jacket cable	1.7 to 3.0

● Accessories

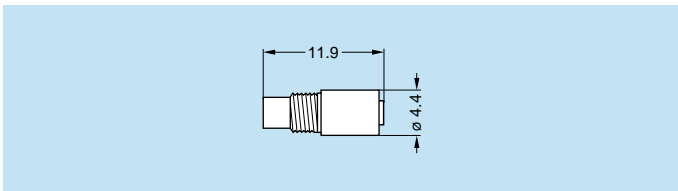

PSS Alignment device for F2 fiber optic contact

Part number	Avail-ability
PSS.F2.290.NZZ	

Note: Alignment device should be ordered as replacement item.

● Insertion and Extraction of the Fiber Optic Contacts

Cable Termination

Detailed instructions for terminating single fiber cables with LEMO F2 fiber optic contacts are given in the reference manual DOC.FO.CF2.0000 supplied with the complete termination workstation (see page 103). After termination contacts shall be introduced in the main insulator as shown below. For purpose of cleaning they can also be removed.

Insertion and Extraction of the F1 Type Contact

Insertion

The fiber optic contact, male or female, terminated on the cable, must be inserted into the connector insulator from the back end until it comes to a stop (step 1 and 2). Check that the contact is correctly retained by gently pulling on it (step 3).

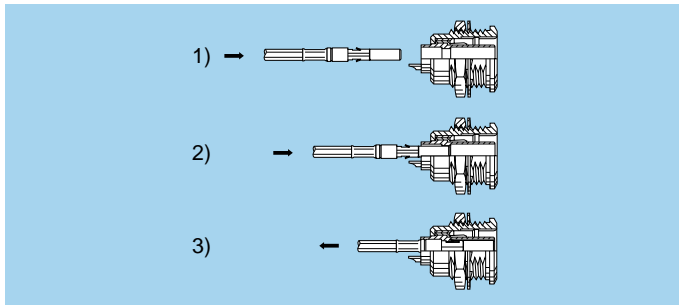

Extraction

Introduce the extractor, reference DCC.91.312.5LA (see page 105), in the insulator around the contact and push until it comes to a stop (step 1 and 2). Gently remove the fiber optic contact by pulling on the cable (step 3).

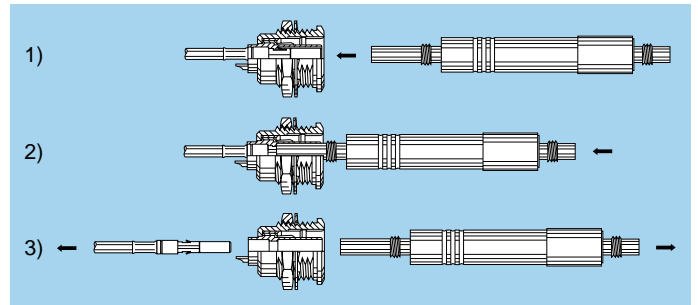

Insertion and Extraction of the F2 Type Contact

Insertion

The male fiber optic contact terminated on the cable must be inserted into the connector insulator from the back end until it comes to a stop. Make sure that the contact is correctly positioned into the inner antirotation key. Key is in line with the red dot on the rear of the contact (step 1). Check that the contact is correctly retained by gently pulling on it (step 2).

For female contacts, the alignment device shall be clipped onto the fiber optic contacts which is already fitted into female insulator. This procedure is performed using the extractor, reference DCC.91.312.5LA. The alignment device shall be first installed onto threaded end of the extractor (step 3). Then clip the adapter (step 4), unscrew and remove the extractor (step 5).

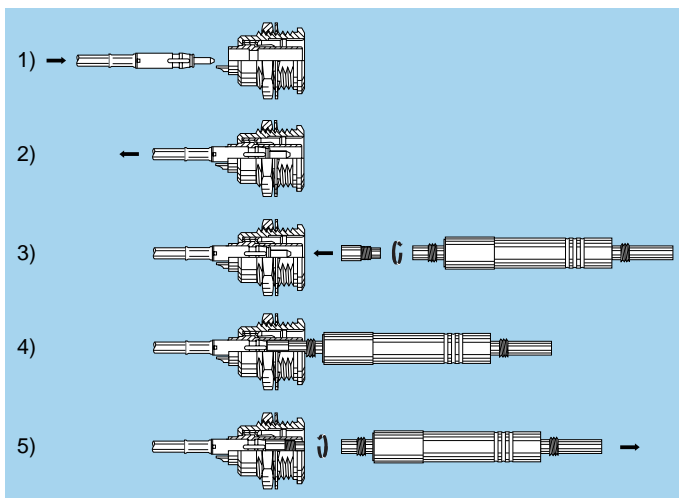

Extraction

Reverse the order of the operation previously described. For female contact remove first the alignment device. Screw the threaded end of the extractor reference, DCC.91.312.5LA (step 1), onto the alignment device and pull out strongly (step 2).

Then use the other side of the extractor, introduce it into the insulator and push until it comes to a stop to compress the contact body (step 3 and 4). Gently remove the fiber optic contact by pulling on the cable (step 5).

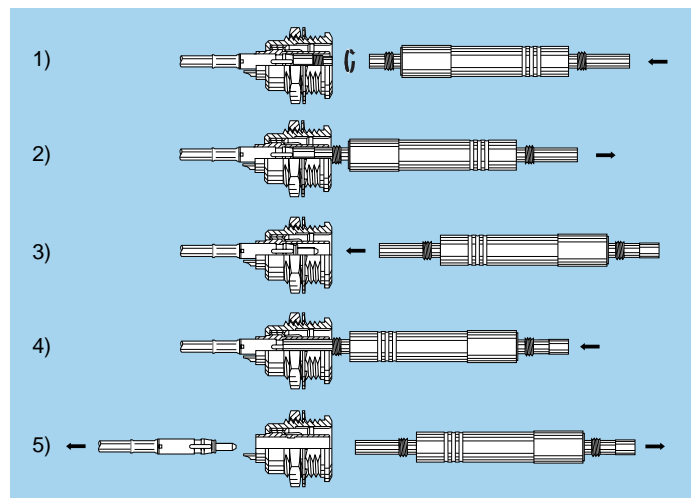

Note: The life time installation of the alignment device is minimum 300 cycles.

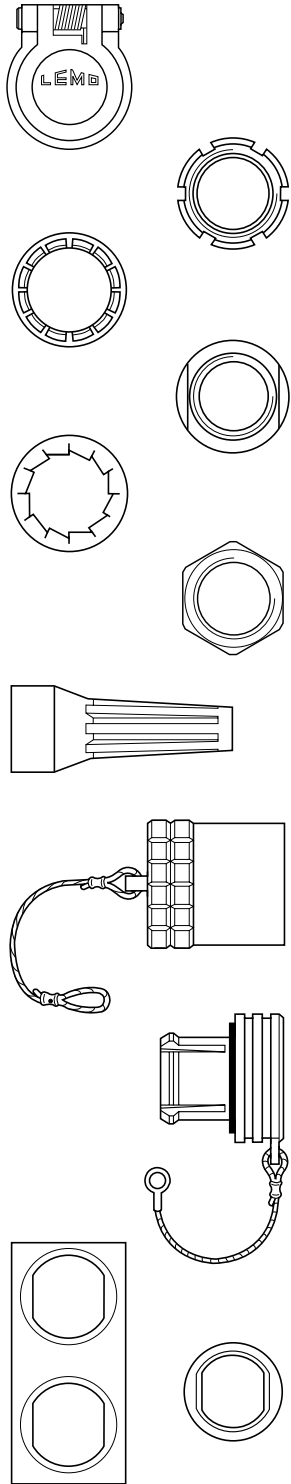

• **Accessories**

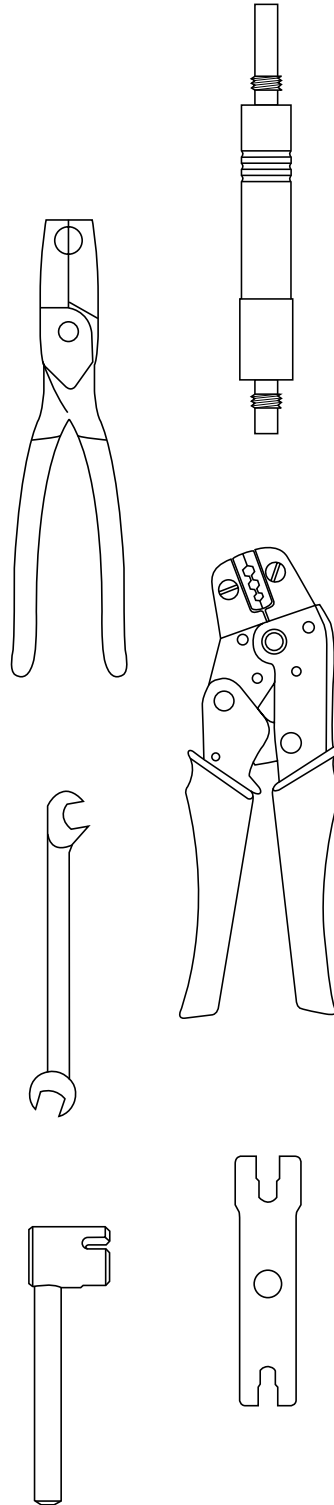

• **Tooling**

● Accessories



FGG-EGG Insulators

Insulators for 2B-5B and 2K-5K series vary according to the fiber optic contact type chosen. They are only necessary as replacement item when electrical crimp contacts are available.

	FO Contact	Insulator part number			
	Type F1	Male contact	Avail-ability	Female contact	Avail-ability
2B 2K	96A	FGG.2B.302.XLY	○	EGG.2B.402.XLY	○
	96C	FGG.2B.304.XLY	○	EGG.2B.404.XLY	○
	96E	FGG.2B.306.XLY	○	EGG.2B.406.XLY	○
	96J	FGG.2B.310.XL	○	EGG.2B.410.XL	○
3B 3K	07A	FGG.3B.302.CL	○	EGG.3B.402.CL	○
	96X	FGG.3B.322.XL	○	EGG.3B.422.XL	○
	97C	FGG.3B.344.XL	○	EGG.3B.444.XL	○
	97E	FGG.3B.346.XL	○	EGG.3B.446.XL	○
	97J	FGG.3B.350.XL	○	EGG.3B.450.XL	○
	97R	FGG.3B.356.XL	○	EGG.3B.456.XL	○
4B 4K	07C	FGG.4B.304.CL	○	EGG.4B.404.CL	○
	99H	FGG.4B.379.XL	○	EGG.4B.479.XL	○
	97F	FGG.4B.347.XL	○	EGG.4B.447.XL	○
	97L	FGG.4B.352.XL	○	EGG.4B.452.XL	○
	97R	FGG.4B.356.XL	○	EGG.4B.456.XL	○
	97T	FGG.4B.358.XL	○	EGG.4B.458.XL	○
	98E	FGG.4B.366.XL	○	EGG.4B.466.XL	○
	98L	FGG.4B.385.XL	○	EGG.4B.485.XL	○
5B 5K	07J	FGG.5B.340.CL	○	EGG.5B.440.CL	○

	FO Contact	Insulator part number			
	Type F2	Male contact	Avail-ability	Female contact	Avail-ability
2B 2K	92A	FGG.2B.302.EL	○	EGG.2B.402.EL	○
	92C	FGG.2B.304.EL	○	EGG.2B.404.EL	○
	92E	FGG.2B.306.EL	○	EGG.2B.406.EL	○
	92J	FGG.2B.310.EL	○	EGG.2B.410.EL	○
3B 3K	03A	FGG.3B.302.EL	○	EGG.3B.402.EL	○
	92X	FGG.3B.322.EL	○	EGG.3B.422.EL	○
	93B	FGG.3B.344.EL	○	EGG.3B.444.EL	○
	93E	FGG.3B.346.EL	○	EGG.3B.446.EL	○
	93J	FGG.3B.350.EL	○	EGG.3B.450.EL	○
	93R	FGG.3B.356.EL	○	EGG.3B.456.EL	○
	87E	FGG.3B.376.WL	○	EGG.3B.476.WL	○
	87R	FGG.3B.386.WL	○	EGG.3B.486.WL	○
4B 4K	03C	FGG.4B.304.EL	○	EGG.4B.404.EL	○
	95D	FGG.4B.375.EL	○	EGG.4B.475.EL	○
	93E	FGG.4B.346.EL	○	EGG.4B.446.EL	○
	93L	FGG.4B.352.EL	○	EGG.4B.452.EL	○
	93R	FGG.4B.356.EL	○	EGG.4B.456.EL	○
	93T	FGG.4B.358.EL	○	EGG.4B.458.EL	○
	94E	FGG.4B.366.EL	○	EGG.4B.466.EL	○
	94L	FGG.4B.385.EL	○	EGG.4B.485.EL	○
	05C	FGG.4B.304.WL	○	EGG.4B.404.WL	○
	88E	FGG.4B.366.WL	○	EGG.4B.466.WL	○
5B 5K	03J	FGG.5B.340.EL	○	EGG.5B.440.EL	○
	03N	FGG.5B.354.EL	○	EGG.5B.454.EL	○
	956	FGG.5B.356.WLL	○	EGG.5B.456.WLL	○
	94B	FGG.5B.383.EL	○	EGG.5B.483.EL	○



FGG-EGG Crimp electrical contacts

	FO Contact		∅ A Contact LV	Contact part number			
	Types			Male	Avail- ability	Female	Avail- ability
	F1	F2					
2B 2K	96A	92A	0.9	FGG.2B.560.ZZC	○	EGG.2B.660.ZZM	○
	96C	92C	0.7	FGG.2B.555.ZZC	○	EGG.2B.655.ZZM	○
	96E	92E	0.7	FGG.2B.555.ZZC	○	EGG.2B.655.ZZM	○
	96J	92J	0.7	FGG.2B.555.ZZC	○	EGG.2B.655.ZZM	○
3B 3K	97C	93B	0.9	FGG.3B.560.ZZC	○	EGG.3B.660.ZZM	○
	97E	93E	0.9	FGG.3B.560.ZZC	○	EGG.3B.660.ZZM	○
	–	87E	0.9	FGG.3B.560.ZZC	○	EGG.3B.660.ZZM	○
	97J	93J	0.7	FGG.3B.555.ZZC	○	EGG.3B.655.ZZM	○
	97R	93R	0.7	FGG.3B.555.ZZC	○	EGG.3B.655.ZZM	○
	96X	92X	0.7	FGG.3B.555.ZZC	○	EGG.3B.655.ZZM	○
	–	87R	0.7	FGG.3B.555.ZZC	○	EGG.3B.655.ZZM	○

	FO Contact		∅ A Contact LV +HV	Contact part number			
	Types			Male	Avail- ability	Female	Avail- ability
	F1	F2					
4B 4K	–	95D	1.3	FGG.4B.565.ZZC	○	EGG.4B.665.ZZM	○
	–	93E	1.3 ¹⁾	FGG.4K.565.ZZCY	○	EGG.3B.665.ZZM	○
			0.9	FGG.4B.560.ZZC	○	EGG.4B.660.ZZM	○
	97F	–	1.3	FGG.4B.565.ZZC	○	EGG.4B.665.ZZM	○
			0.9	FGG.4B.560.ZZC	○	EGG.4B.660.ZZM	○
	97R	93R	0.9	FGG.4B.560.ZZC	○	EGG.4B.660.ZZM	○
	97L	93L	0.9	FGG.4B.560.ZZC	○	EGG.4B.660.ZZM	○
	98L	94L	0.7	FGG.4B.555.ZZC	○	EGG.4B.655.ZZM	○
	97T	93T	0.7	FGG.4B.555.ZZC	○	EGG.4B.655.ZZM	○
	–	88E	0.7	FGG.4B.555.ZZC	○	EGG.4B.655.ZZM	○
99H	–	0.7	FGG.4B.555.ZZC	○	EGG.4B.655.ZZM	○	
98E	94E	0.7	FGG.4B.555.ZZC	○	EGG.4B.655.ZZM	○	
5B 5K	–	94B	2.0	FGG.5B.575.ZZC	○	EGG.5B.675.ZZM	○
	–	956	2.0 ¹⁾	FGG.3B.575.ZZC	○	EGG.4B.675.ZZM	○
			1.6 ¹⁾	FGG.4B.570.ZZC	○	EGG.2B.670.ZZM	○
	–	90C	1.6 ¹⁾	FGG.4B.570.ZZC	○	EGG.2B.670.ZZM	○

Note: 1) Arrangements with special contact length.

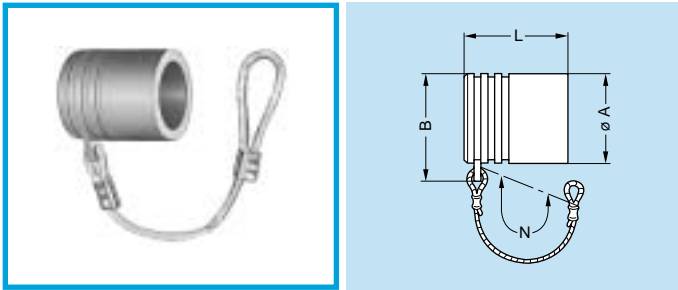

- Body material: Polyoxymethylene (POM) grey (or black)
- Cord material: Polyamide 6, white (or black)
- Crimp ferrule material: Nickel-plated brass
- Gasket material: Silicone rubber
- Maximum operating temperature: 212°F
- Watertightness: IP61 according to IEC 60529

BFG Plug caps

Part number	Series	Dimensions (mm)				Availability
		A	B	L	N	
BFG.00.100.PCSG	00	7.5	10	10.0	60	○
BFG.0B.100.PCSG	0B	9.5	12	12.2	85	○
BFG.2B.100.PCSG	2B	15.0	18	15.0	85	○
BFG.3B.100.PCSG	3B	18.5	22	18.5	95	○

Note: This cap is available only with an alignment key (G). Upon request this cap can be supplied in black and the last letter «G» of the part number should be replaced with «N».

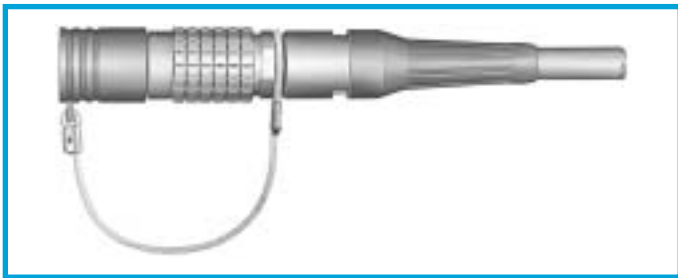

Fitting the cord

Slide the plug into the loop of the cord. Place the loop into the groove in front of the collet nut and tighten the loop.

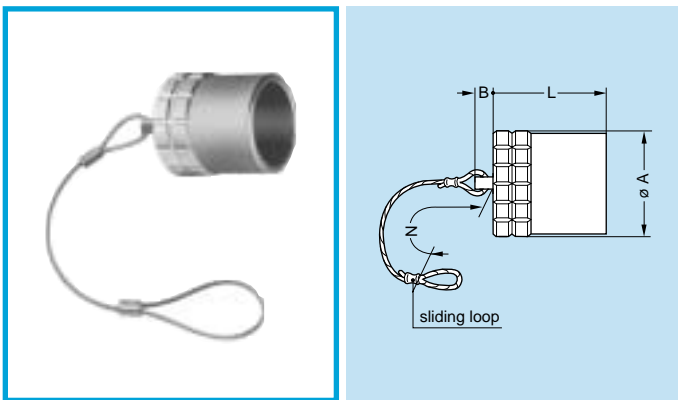

- Body material: Nickel-plated brass (Ni 3µm)
- Lanyard material: Stainless steel
- Crimp ferrule material: Nickel-plated brass + polyolefin
- O-ring material: Silicone rubber or FPM
- Maximum operating temperature: 275°F
- Watertightness: IP68 according to IEC 60529 for K series

BFG Plug caps with key (G)

Part number	Series	Dimensions (mm)				Availability
		A	B	L	N	
BFG.0K.100.NAS	0K	14.0	6	15.0	85	○
BFG.2K.100.NAS	2K	19.5	6	20.0	85	○
BFG.3K.100.NAS	3K	23.0	6	24.0	120	○
BFG.4B.100.NAS	4B	25.0	10	20.0	120	○
BFG.4K.100.NAS	4K	29.0	10	24.5	120	○
BFG.5B.100.NAS	5B	36.0	10	27.0	150	○
BFG.5K.100.NAS	5K	44.0	10	29.0	150	○

Note: This cap is available only with an alignment key (G). The last letter «S» of the part number stands for the material of the O-ring (silicone rubber). O-rings made from FPM are also available; if required, replace the letter «S» by «V».

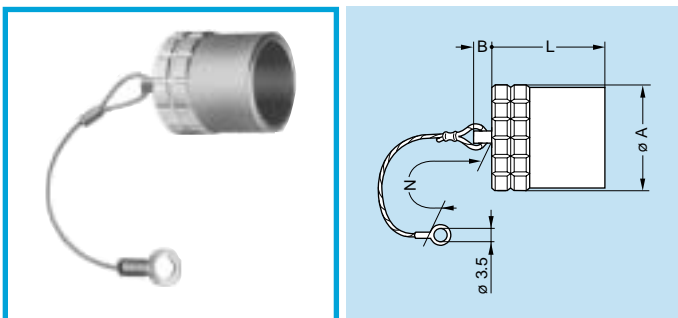

- Body material: Nickel-plated brass (Ni 3µm)
- Lanyard material: Stainless steel
- Crimp ferrule material: Nickel-plated brass + polyolefin
- O-ring material: Silicone rubber or FPM
- Maximum operating temperature: 275°F
- Watertightness: IP68 according to IEC 60529 for K series

BHG Plug caps, nut fixing or flange

Part number	Series	Dimensions (mm)				Availability
		A	B	L	N	
BHG.0K.100.NAS	0K	14.0	6	15.0	85	○
BHG.2K.100.NAS	2K	19.5	6	20.0	85	○
BHG.3K.100.NAS	3K	23.0	6	24.0	120	○
BHG.4B.100.NAS	4B	25.0	10	20.0	120	○
BHG.4K.100.NAS	4K	29.0	10	24.5	120	○
BHG.5B.100.NAS	5B	36.0	10	27.0	150	○
BHG.5K.100.NAS	5K	44.0	10	29.0	150	○

Note: This cap is available only with an alignment key (G). The last letter «S» of the part number stands for the material of the O-ring (silicone rubber). O-rings made from FPM are also available; if required, replace the letter «S» by «V».

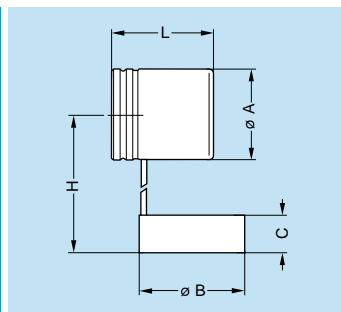

BFA Plug cap

Part number	Series	Dimensions (mm)					Availability
		A	B	C	H	L	
BFA.3K.170.800EN	3K	24	28	10	80	27	○

- Material: black EPDM

Note: These caps are suitable for use with any alignment key

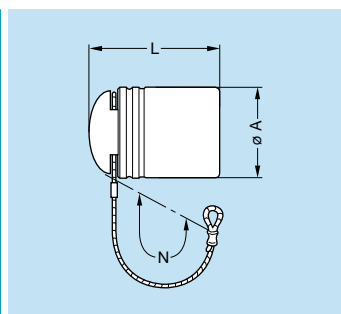

BFG Plug cap

Part number	Series	Dimensions (mm)			Availability
		A	L	N	
BFG.3K.100.EAN	3K	24	30	155	○

- Material: black EPDM
- Lanyard material: Stainless steel
- Crimp ferrule material: Nickel-plated brass + polyolefin

Note: These caps are suitable for use with any alignment key

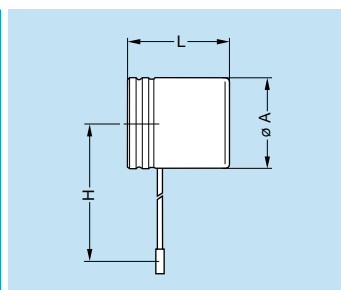

BHA Plug cap

Part number	Series	Dimensions (mm)			Availability
		A	H	L	
BHA.3K.100.715EN	3K	24	80	27	○

- Material: black EPDM

Note: These caps are suitable for use with any alignment key

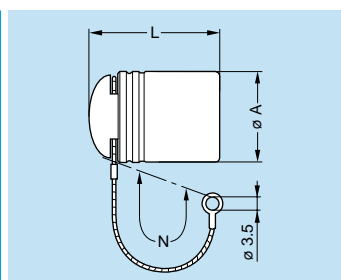
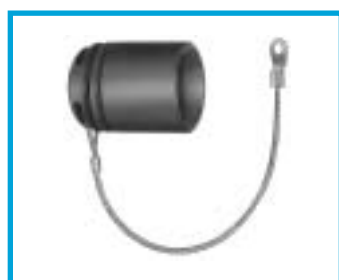

BHA Plug cap

Part number	Series	Dimensions (mm)			Availability
		A	L	N	
BHA.3K.100.EAN	3K	24	30	120	○

- Material: black EPDM
- Lanyard material: Stainless steel
- Crimp ferrule material: Nickel-plated brass + polyolefin

Note: These caps are suitable for use with any alignment key

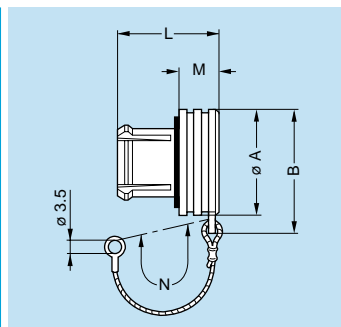

BRA Blanking caps for fixed receptacles

Part number	Series	Dimensions (mm)					Availability
		A	B	L	M	N	
BRA.00.200.PCSG	00	7.5	10.0	8.2	2.7	60	○
BRA.0B.200.PCSG	0B	10.0	12.5	11.0	4.8	60	○
BRA.2B.200.PCSG	2B	18.0	21.0	14.5	6.0	60	○
BRA.3B.200.PCSG	3B	22.0	25.5	17.0	7.0	60	○

Note: These caps are suitable for use with any alignment key configuration. On request this cap can be supplied in black. If so, replace the last letter 'G' of the part number by 'N'.

- Body material: Polyoxymethylene (POM) grey (or black)
- Cord material: Polyamide 6, white (or black)
- Crimp ferrule material: Nickel-plated brass
- Gasket material: Silicone rubber
- Maximum operating temperature: 212°F
- Watertightness: IP61 according to IEC 60529

● Standard, typically 0-6 weeks delivery for quantities of 250 or less.
 ○ Non-standard product, contact LEMO USA, typically 6-12 weeks delivery for quantities of 250 or less.
 Non-standard product is defined as any product which contains one or more components which are not standard.

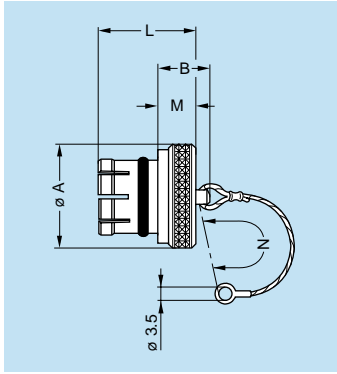

- Body material: Nickel-plated brass (Ni 3 μm)
- Lanyard material: Stainless steel
- Crimp ferrule material: Nickel-plated brass + polyolefin
- O-ring material: Silicone rubber or FPM
- Maximum operating temperature: 275°F

BRE Blanking caps for fixed receptacles

Part number	Series	Dimensions (mm)					Availability
		A	B	L	M	N	
BRE.00.200.NAS	00	8	9.5	8.8	3.5	60	○
BRE.0S.200.NAS	0B	10	10.5	10.5	4.5	85	○
BRE.2S.200.NAS	2B	18	12.0	14.0	6.0	85	○
BRE.3S.200.NAS	3B	22	14.0	18.0	8.0	120	○
BRE.4S.200.NAS	4B	28	20.0	23.0	10.0	120	○
BRE.5S.200.NAS	5B	40	22.0	30.0	12.0	150	○

Note: These caps are suitable for use with any alignment key configuration. The last letter «S» of the part number stands for the O-ring material (silicone rubber). O-rings made from FPM are also available; if required, replace the letter «S» by «V».

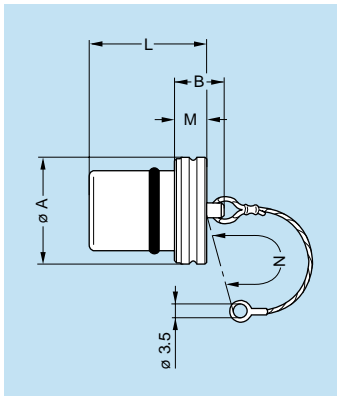

- Body material: Nickel-plated brass (Ni 3 μm)
- Lanyard material: Stainless steel
- Crimp ferrule material: Nickel-plated brass + polyolefines
- O-ring material: Silicone rubber or FPM
- Maximum operating temperature: 275°F
- Watertightness: IP68 according to IEC 60529

BRE Blanking caps for fixed receptacles

Part number	Series	Dimensions (mm)					Availability
		A	B	L	M	N	
BRE.0K.200.NAS	0K	15.0	10	15.0	4	85	○
BRE.2K.200.NAS	2K	20.5	14	24.0	8	85	○
BRE.3K.200.NAS	3K	24.0	14	28.0	8	120	○
BRE.4K.200.NAS	4K	30.0	20	30.5	10	120	○
BRE.5K.200.NAS	5K	44.0	22	37.0	12	150	○

Note: These caps are suitable for use with any alignment key configuration. The last letter «S» of the part number stands for the O-ring material (silicone rubber). O-rings made from FPM are also available; if required, replace the letter «S» by «V».

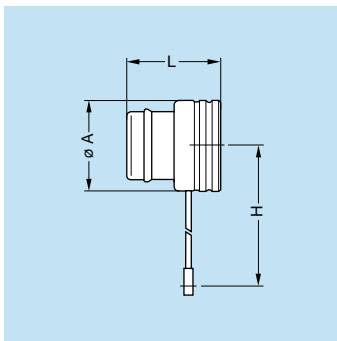

BRA Blanking cap for fixed receptacles

Part number	Series	Dimensions (mm)			Availability
		A	H	L	
BRA.3K.100.715EN	3K	24	80	25	○

- Material: black EPDM

Note: These caps are suitable for use with any alignment key configuration.

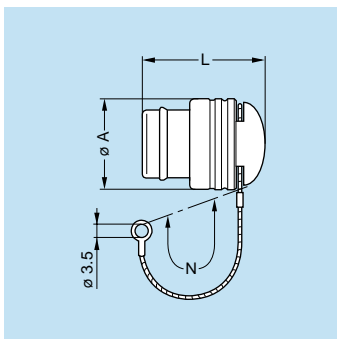

BRA Blanking cap for fixed receptacles

Part number	Series	Dimensions (mm)			Availability
		A	L	N	
BRA.3K.200.EAN	3K	24	26	120	

- Material: black EPDM
- Lanyard material: Stainless steel
- Crimp ferrule material: Nickel-plated brass + polyolefin

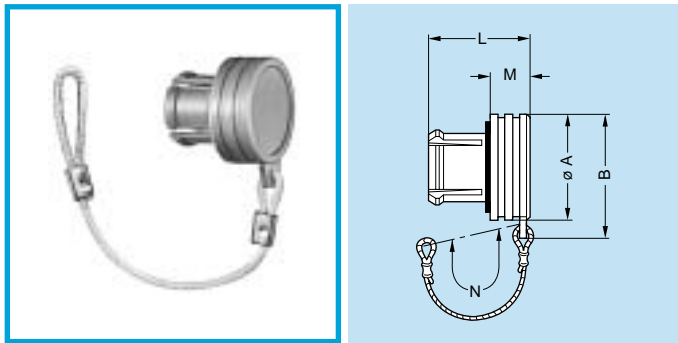

- Body material: Polyoxymethylene (POM) grey (or black)
- Cord material: Polyamide 6, white (or black)
- Crimp ferrule material: Nickel-plated brass
- Gasket material: Silicone rubber
- Maximum operating temperature: 212°F
- Watertightness: IP61 according to IEC 60529

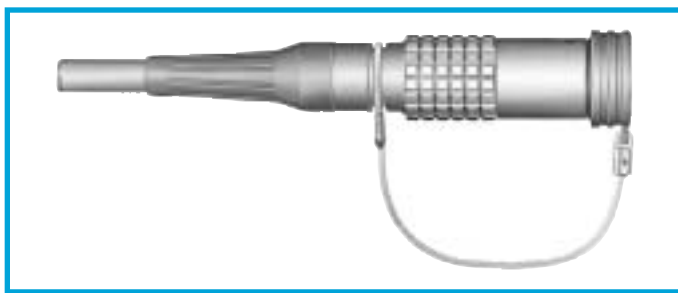

BRD Blanking caps for free receptacles

Part number	Series	Dimensions (mm)					Availability
		A	B	L	M	N	
BRD.00.200.PCSG	00	7.5	10.0	8.2	2.7	60	○
BRD.0B.200.PCSG	0B	10.0	12.5	11.0	4.8	85	○
BRD.2B.200.PCSG	2B	18.0	21.0	14.5	6.0	85	○
BRD.3B.200.PCSG	3B	22.0	25.5	17.0	7.0	95	○

Note: On request this cap is available in black. If required, replace the last letter «G» of the part number by «N».

Fitting the cord

Slide the receptacle into the loop of the cord.
Place the loop into the groove in front of the collet nut.
Tighten the loop.

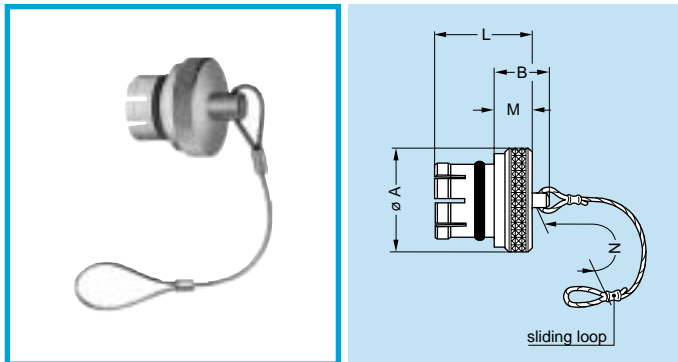

- Body material: Nickel-plated brass (Ni 3 µm)
- Lanyard material: Stainless steel
- Crimp ferrule material: Nickel-plated brass + polyolefin
- O-ring material: Silicone rubber or FPM
- Maximum operating temperature: 275°F

BRF Blanking caps for free receptacles

Part number	Series	Dimensions (mm)					Availability
		A	B	L	M	N	
BRF.00.200.NAS	00	8	9.5	8.8	3.5	85	○
BRF.0S.200.NAS	0B	10	10.5	10.5	4.5	85	○
BRF.2S.200.NAS	2B	18	12.0	14.0	6.0	85	○
BRF.3S.200.NAS	3B	22	14.0	18.0	8.0	120	○
BRF.4S.200.NAS	4B	28	20.0	23.0	10.0	120	○
BRF.5S.200.NAS	5B	40	22.0	30.0	12.0	150	○

Note: These caps are suitable for use with any alignment key configuration. The last letter «S» of the part number stands for the O-ring material (silicone rubber). O-rings made from FPM are also available; if required, replace the letter «S» by «V».

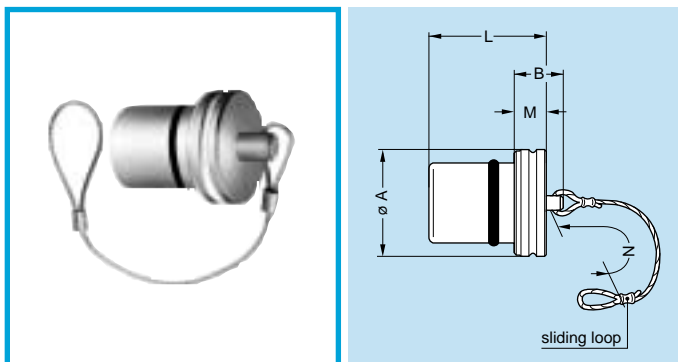

- Body material: Nickel-plated brass (Ni 3 µm)
- Lanyard material: Stainless steel
- Crimp ferrule material: Nickel-plated brass + polyolefin
- O-ring material: Silicone rubber or FPM

BRF Blanking caps for free receptacles

Part number	Series	Dimensions (mm)					Availability
		A	B	L	M	N	
BRF.0K.200.NAS	0K	15.0	10	15.0	4	85	○
BRF.2K.200.NAS	2K	20.5	14	24.0	8	85	○
BRF.3K.200.NAS	3K	24.0	14	28.0	8	120	○
BRF.4K.200.NAS	4K	30.0	20	30.5	10	120	○
BRF.5K.200.NAS	5K	44.0	22	37.0	12	150	○

Note: These caps are suitable for use with any alignment key configuration. The last letter «S» of the part number stands for the O-ring material (silicone rubber). O-rings made from FPM are also available; if required, replace the letter «S» by «V».

- Maximum operating temperature: 275°F
- Watertightness: IP68 according to IEC 60529

● Standard, typically 0-6 weeks delivery for quantities of 250 or less.
○ Non-standard product, contact LEMO USA, typically 6-12 weeks delivery for quantities of 250 or less.
Non-standard product is defined as any product which contains one or more components which are not standard.

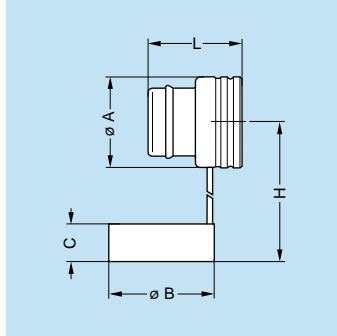
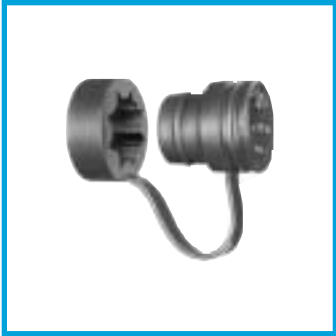

BRD Blanking caps for free receptacles

Part number	Series	Dimensions (mm)					Availability
		A	B	C	H	L	
BRD.3K.170.800EN	3K	24	28	10	80	25	○

- Material: black EPDM

Note: These caps are suitable for use with any alignment key configuration.

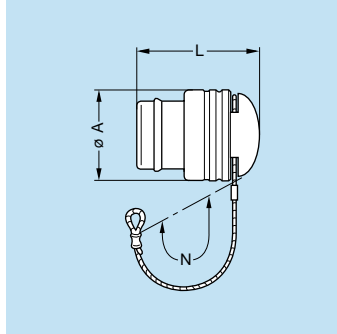

BRF Blanking caps for free receptacles

Part number	Series	Dimensions (mm)			Availability
		A	L	N	
BRF.3K.200.EAN	3K	24	26	155	○

- Material: black EPDM
- Lanyard material: Stainless steel
- Crimp ferrule material: Nickel-plated brass + polyolefin

Note: These caps are suitable for use with any alignment key

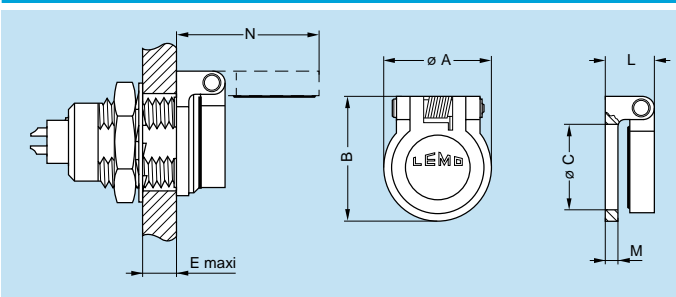

BRR Spring loaded dust caps for PK fixed receptacles

Part number	Series	Dimensions (mm)							Availability
		A	B	C	E	L	M	N	
BRR.0S.200.PZSG	0B	11.0	13.3	9.0	5.8	5.0	1.2	15.3	○
BRR.2S.200.PZSG	2B	18.6	22.4	15.2	6.5	8.2	2.0	26.2	○
BRR.3S.200.PZSG	3B	22.5	26.5	18.2	9.0	8.8	2.5	30.8	○

Note: On request, this cap is available in black. If so replace the last letter «G» of the part number by «N».

- Body material: Polyoxymethylene (POM) grey (or black)
- Gasket material: Silicone rubber
- Spring material: Stainless steel
- Axes material: Nickel-plated brass
- Maximum operating temperature: 212°F
- Watertightness: IP61 according to IEC 60529

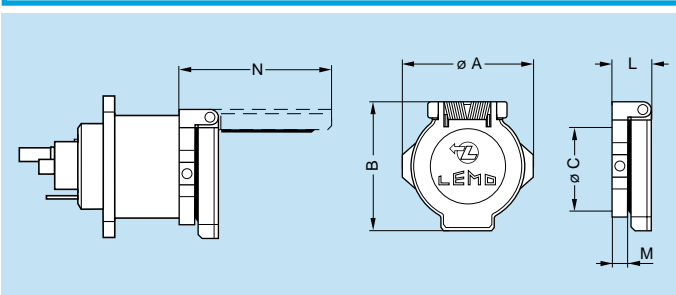

BRR Spring loaded dust cap for ED, EB and PB receptacles

Part number	Series	Dimensions (mm)					Availability	
		A	B	C	L	M		
BRR.3K.200.PZSG	3K	29	29	23	8.1	3	33.2	○

Note: On request, this cap is available in black. If so replace the last letter «G» of the part number by «N».

- Cap material: Polyoxymethylene (POM) grey (or black)
- Body material: Nickel-plated brass
- Gasket material: Silicone rubber
- Spring material: Stainless steel
- Axes material: Nickel-plated brass
- Maximum operating temperature: 212°F
- Watertightness: IP61 according to IEC 60529

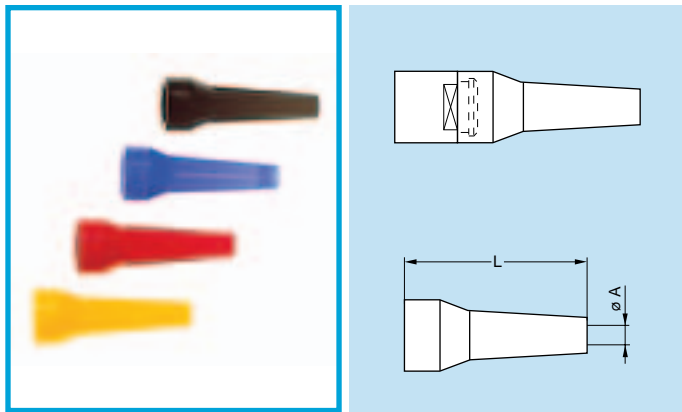

GM• Bend reliefs (Polyurethane)

A bend relief made from thermoplastic polyurethane elastomer (Desmopan 786) can be fitted over LEMO plugs and receptacles that are supplied with a specially fitted nut. These are available in nine different colors that match with the GRA insulating washers (see page 93).

Use the part numbers shown below to order this accessory separately.

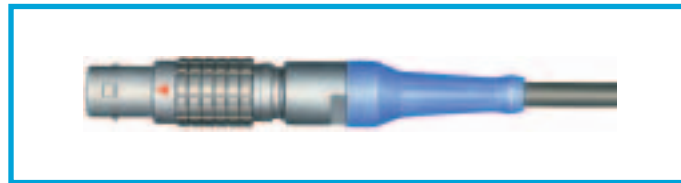

Main characteristics

- Material: Polyurethane elastomer
- Temperature range in dry atmosphere: -40°F to +176°F

Part number	Dimensions (mm)				Series	Part number of nut for fitting the bend relief	Availability
	Bend relief		Cable ø				
	A	L	max.	min.			
GMA.00.012.DG	1.2	22	1.4	1.1	00	FFM.00.131.LC	○
GMA.00.018.DG	1.8	22	2.1	1.8			○
GMD.00.025.DG	2.5	22	2.8	2.5			○
GMD.00.028.DG	2.8	22	3.1	2.8			○
GMD.00.032.DG	3.2	22	3.5	3.2			○
GMA.0B.025.DG	2.5	24	2.9	2.5	0B	FFM.0B.130.LC	○
GMA.0B.030.DG	3.0	24	3.4	3.0	2B	FFM.2B.132.LC 1)	○
GMA.0B.035.DG	3.5	24	3.9	3.5			○
GMA.0B.040.DG	4.0	24	4.4	4.0	0K	FFM.0E.130.LC	○
GMA.0B.045.DG	4.5	24	5.2	4.5			○
GMA.1B.040.DG	4.0	30	4.4	4.0	3B	FFM.3B.131.LC 2)	○
GMA.1B.045.DG	4.5	30	4.9	4.5			○
GMA.1B.054.DG	5.4	30	6.0	5.4			○
GMA.2B.040.DG	4.0	36	4.5	4.0	2B	FFM.2B.130.LC	○
GMA.2B.045.DG	4.5	36	5.0	4.5	4B	FFM.4B.132.LC 3)	○
GMA.2B.050.DG	5.0	36	5.5	5.0	2K	FFM.2E.130.LC	○
GMA.2B.060.DG	6.0	36	6.5	6.0	3K	FFM.3K.133.LC	○
GMA.2B.070.DG	7.0	36	7.7	7.0	4K	FFM.4K.132.LC	○
GMA.2B.080.DG	7.8	36	8.8	7.8	5K	FFM.5K.132.LC	○
GMA.3B.050.DG	4.5	42	5.2	4.5	3B	FFM.3B.130.LC	○
GMA.3B.060.DG	6.0	42	6.9	6.0			○
GMA.3B.070.DG	7.0	42	7.9	7.0	3K	FFM.3E.130.LC	○
GMA.3B.080.DG	8.0	42	8.9	8.0			○
GMA.3B.090.DG	9.0	42	10.0	9.0	4K	FFM.4K.133.LC	○
GMA.4B.080.DG	8.0	60	9.0	8.0	4B	FFM.4B.130.LC	○
GMA.4B.010.DG	10.0	60	10.9	10.0			○
GMA.4B.011.DG	11.0	60	11.9	11.0	4K	FFM.3K.132.LC	○
GMA.4B.012.DG	12.0	60	13.0	12.0			○
GMA.4B.013.DG	13.5	60	14.5	13.5	5K	FFM.5K.133.LC	○

Note: The last letter «G» of the part number indicates the grey color of the bend relief. For ordering a bend relief with another color, see table on page 92 and replace the letter «G» by the letter of the required color.

See also detailed information for each series: B series on page 62; K series on page 62.

1) For use only with connectors from series 2B equipped with cable fixing type M and where a bend relief from series 0B is used.

2) For use only with connectors from series 3B equipped with cable fixing type M and where a bend relief from series 1B is used.

3) For use only with connectors from series 4B equipped with cable fixing type M and where a bend relief from series 2B is used.

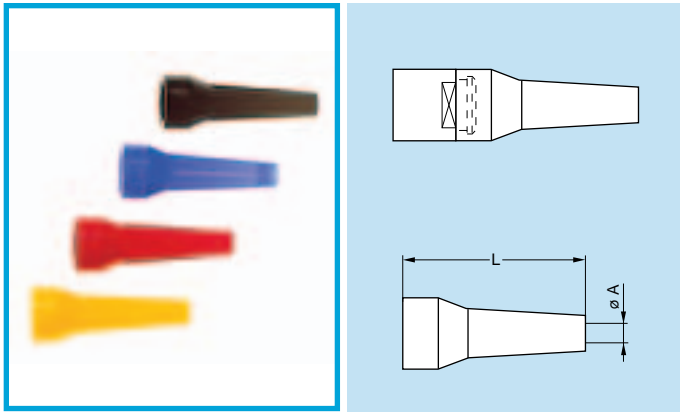

GM• Bend reliefs (Silicone)

A bend relief has been designed for connectors used in applications at high temperature or requiring vapor sterilization.

These bend reliefs are different from previous ones; their material, a silicone elastomer, is noted for its retention of flexibility over a wide temperature range. They are available in nine colors.

Use the part numbers shown below to order this accessory separately.

Main characteristics

- Material: Silicone elastomer VMQ
- Temperature range in dry atmosphere: -76°F to +392°F
- Temperature range in water steam: +284°F
- Inflammability: not flammable (no UL classification)

Part number	Dimensions (mm)				Series	Part number of nut for fitting the bend relief	Availability
	Bend relief		Cable \varnothing				
	A	L	max.	min.			
GMA.0B.025.RG	2.5	27	2.9	2.5	0B	FFM.0B.130.LC	○
GMA.0B.030.RG	3.0	27	3.4	3.0			○
GMA.0B.035.RG	3.5	27	3.9	3.5	2B	FFM.2B.132.LC ¹⁾	○
GMA.0B.040.RG	4.0	27	4.4	4.0			○
GMA.0B.045.RG	4.5	27	5.2	4.5	0K	FFM.0E.130.LC	○
GMA.1B.040.RG	4.0	34	4.4	4.0	3B	FFM.3B.131.LC ²⁾	○
GMA.1B.045.RG	4.5	34	5.0	4.5			○
GMA.2B.040.RG	4.0	41	4.4	4.0	2B	FFM.2B.130.LC	○
GMA.2B.045.RG	4.5	41	5.0	4.5	4B	FFM.4B.132.LC ³⁾	○
GMA.2B.051.RG	5.1	41	5.6	5.1	2K	FFM.2E.130.LC	○
GMA.2B.057.RG	5.7	41	6.2	5.7	3K	FFM.3K.133.LC	○
GMA.2B.063.RG	6.3	41	7.0	6.3	4K	FFM.4K.132.LC	○
GMA.2B.071.RG	7.1	41	7.9	7.1	5K	FFM.5K.132.LC	○
GMA.2B.080.RG	8.0	41	9.0	8.0			○

Note: The last letter «G» of the part number indicates the grey color of the bend relief. For ordering a bend relief with another color, see table below and replace the letter «G» by the letter of the required color.

See also detailed information for each series: B series on page 62; K series on page 62.

¹⁾ For use only with connectors from series 2B equipped with cable fixing type M and where a bend relief from series 0B is used.

²⁾ For use only with connectors from series 3B equipped with cable fixing type M and where a bend relief from series 1B is used.

³⁾ For use only with connectors from series 4B equipped with cable fixing type M and where a bend relief from series 2B is used.

Note: The selection of pigments, which should remain stable at high temperature, is limited by new regulations. For this reason, some colors will be a shade different from those used for Desmopan bend reliefs. The selected solutions represent the best possible compromise.

Ref.	Color
A	blue
B	white
G	grey
J	yellow
M	brown

Ref.	Color
N	black
R	red
S	orange
V	green

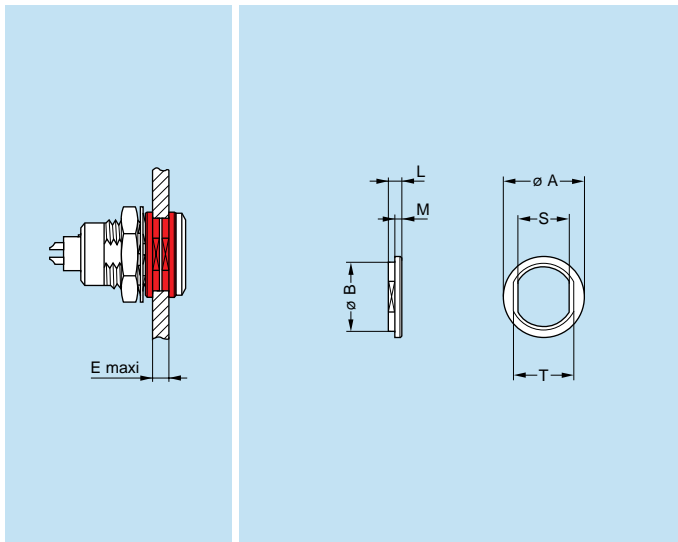

- Material: Polyamide
- Maximum operating temperature: 194°F

GRA Insulating washers

Receptacles or plugs mounted on panels can be fitted with insulating washers. The nine colors available combined with those for the overall protective coverings with bend relief makes color coding possible.

Part number	Series	Dimensions (mm)							Availability
		A	B	E	L	M	S	T	
GRA.00.269.GG	00	10	8.8	4.5	1.8	1.0	6.4	8.0	○
GRA.0S.269.GG	0B	12	10.8	6.0	1.8	1.0	8.3	9.9	○
GRA.2S.269.GG	2B	21	17.8	7.3	2.2	1.2	13.6	16.2	○
GRA.3S.269.GG	3B	25	21.8	10.3	2.2	1.2	16.6	20.2	○
GRA.4S.269.GG	4B	32	28.8	10.5	2.5	1.5	23.7	27.2	○

Note: Insulating washers for series 5B are available on request.

Caution: These insulating washers can be used with fixed and straight receptacles with across flat dimension S1 equivalent to the S dimension of the washer.

Ref.	Color	Ref.	Color
A	blue	N	black
B	white	R	red
G	grey	S	orange
J	yellow	V	green
M	brown		

Note: The last letter «G» of the part number indicates the color grey for the insulating washer. To obtain an insulating washer of another color, refer to the table above and change the letter «G» of the part number to the corresponding letter of the color required.

For the panel cut-out, please consult pages 23, 31 and 48.

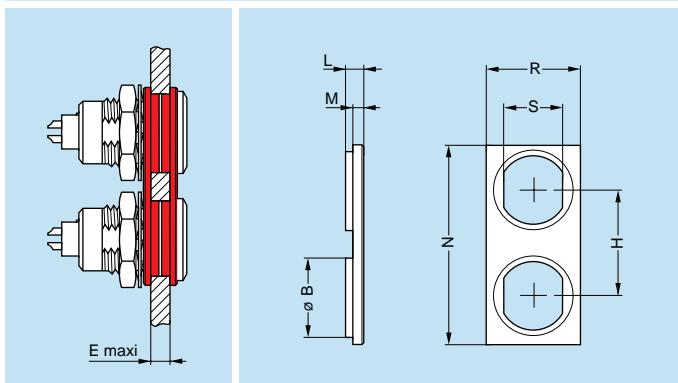

- Material: Polyamide
- Maximum operating temperature: 194°F

GRC Double panel washers

Double panel washers have been designed to make the drilling of panel holes easier for mounting fixed and straight receptacles. The combination of the nine different colors of the double panel washers and of the overall protective coverings with bend relief makes color coding possible.

Part number	Series	Dimensions (mm)							Availability	
		B	E	H	L	M	N	R		S
GRC.0S.260.HG	0B	10.9	5	14	2.5	1.5	26.5	12.5	8.3	○

Caution: These double panel washers can be used with fixed or free receptacles with across flat dimension S1 equivalent to the S dimension of the washer.

Ref.	Color	Ref.	Color
A	blue	N	black
B	white	R	red
G	grey	S	orange
J	yellow	V	green
M	brown		

Note: The last letter «G» of the washer's part number indicates the color grey. For other colors, refer to the above table and replace letter «G» by the one corresponding to the color required.

For the panel cut-out, please consult chapter «Panel cut-out» on page 31.

● Standard, typically 0-6 weeks delivery for quantities of 250 or less.
 ○ Non-standard product, contact LEMO USA, typically 6-12 weeks delivery for quantities of 250 or less.
 Non-standard product is defined as any product which contains one or more components which are not standard.

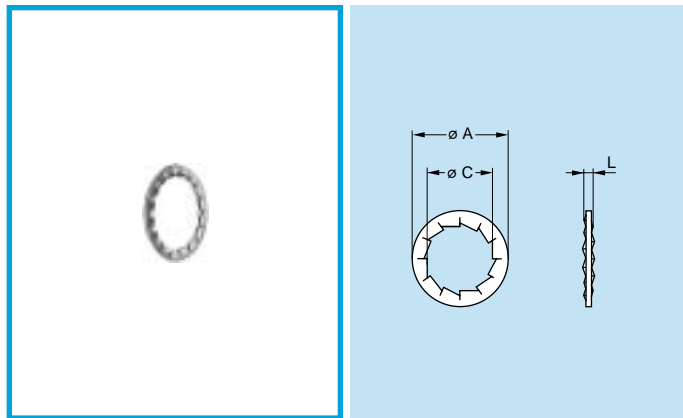

GBA Locking washers

Part number	Series	Dimensions (mm)			Availability
		A	C	L	
GBA.00.250.FN	00	9.5	7.1	1.0	●
GBA.0S.250.FN	0B	12.5	9.1	1.0	●
GBA.2S.250.FN	2B	19.5	15.1	1.2	●
GBA.3S.250.FN	3B	25.0	18.1	1.4	○
GBA.4S.250.FN	4B	32.0	25.1	1.4	○

Note: To order this accessory separately, use the above part numbers.

● Material: Nickel-plated bronze (3 μ m)

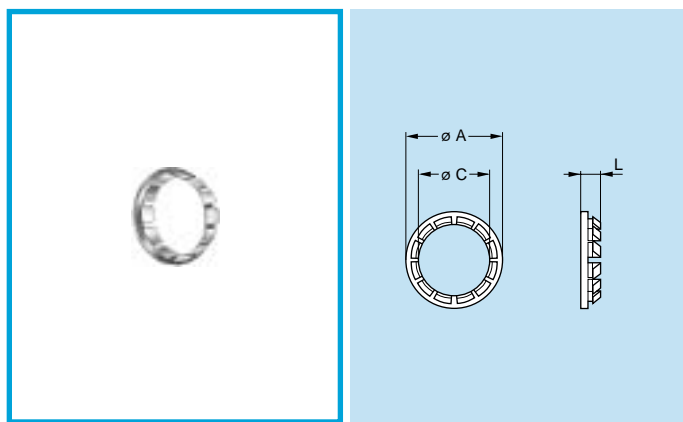

GBB Tapered washers

Part number	Series	Dimensions (mm)			Availability
		A	C	L	
GBB.00.250.LN	00	9	7.1	2.0	○
GBB.0S.250.LN	0B	11	9.1	2.5	○
GBB.2S.250.LN	2B	18	15.1	4.0	○
GBB.3S.250.LN	3B	22	18.1	4.5	○
GBB.4S.250.LN	4B	28	25.2	5.0	○
GBB.5S.250.LN	5B	40	35.2	7.5	○

Note: Receptacles of series 5B are always supplied with a tapered washer. To order this accessory separately, use the above part numbers.

● Material: Nickel-plated brass (3 μ m)

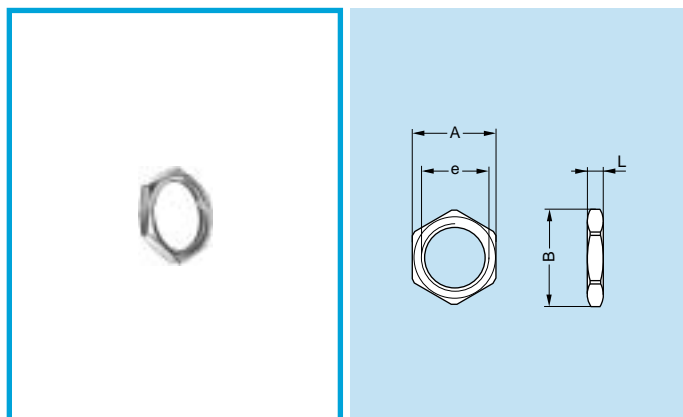

GEA Hexagonal nuts

Part number	Series	Dimensions (mm)				Availability
		A	B	e	L	
GEA.00.240.LN	00	9	10.2	M7 x 0.50	2.0	●
GEA.0S.240.LN	0B	11	12.4	M 9 x 0.60	2.0	●
GEA.0E.240.LN	0K	17	19.2	M14 x 1.00	2.5	●
GEA.2S.240.LN	2B	17	19.2	M15 x 1.00	2.7	●
GEA.2E.240.LN	2K	24	27.0	M20 x 1.00	4.0	●
GEA.3S.240.LN	3B	22	25.0	M18 x 1.00	3.0	●
GEA.3E.240.LN	3K	30	34.0	M24 x 1.00	5.0	●
GEA.4S.240.LN	4B	30	34.0	M25 x 1.00	5.0	○
GEA.4E.240.LN	4K	36	40.5	M30 x 1.00	7.0	○

Note: To order this part separately, use the above part numbers. The last letters «LN» of the part number refer to the nut material and treatment. If a nut in aluminium alloy or stainless steel is desired, replace the last letters of the part number by «PT» or «AZ» respectively.

● Material:
 – Nickel-plated brass (3 μ m)
 – Natural anodized aluminium alloy
 – Stainless steel

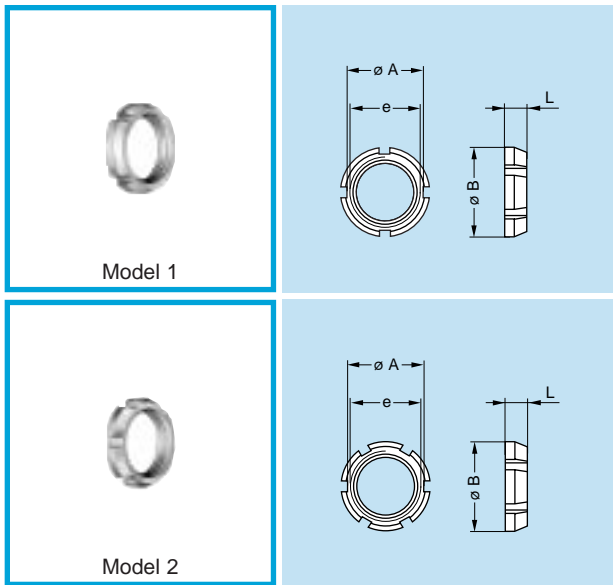

GEG Notched nuts

Part number	Series	Model	Dimensions (mm)				Availability
			A	B	e	L	
GEG.00.240.LC	00	1	8.7	10	M7 x 0.5	2.5	●
GEG.0S.240.LC	0B	1	10.5	12	M9 x 0.6	2.5	●
GEG.0E.240.LC	0K	1	15.8	18	M14 x 1.0	3.5	●
GEG.2S.240.LC	2B	2	17.5	20	M15 x 1.0	3.5	●
GEG.2E.240.LC	2K	2	22.5	25	M20 x 1.0	3.5	●

● Material: Chrome-plated brass (Ni 3 µm + Cr 0.3 µm)

Note: 00, 0B and 2B series fixed and free receptacles for back panel mounting are always delivered with this notched nut. To order this accessory separately, use the above part numbers.

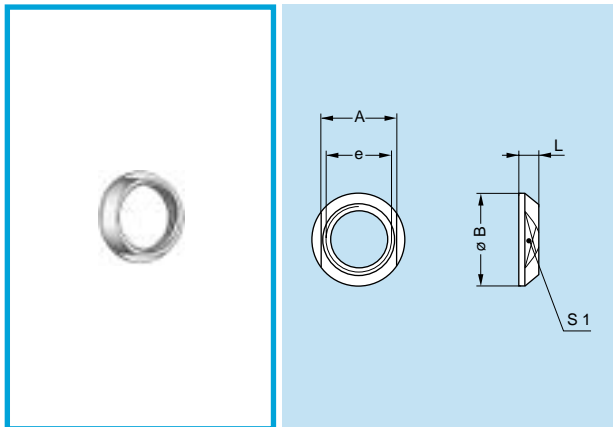

GEC Conical nuts

Part number	Series	Dimensions (mm)					Availability
		A	B	e	L	S1	
GEC.00.240.LC	00	8	10.0	M7 x 0.5	2.5	8	○
GEC.0S.240.LC	0B	10	12.0	M9 x 0.6	2.5	10	○
GEC.0E.240.LC	0K	16	18.0	M14 x 1.0	3.0	16	○
GEC.2S.240.LC	2B	17	20.0	M15 x 1.0	3.8	17	○
GEC.2E.240.LC	2K	22	25.0	M20 x 1.0	5.0	20	○
GEC.3S.240.LC	3B	20	24.0	M18 x 1.0	4.5	20	○
GEC.3E.240.LC	3K	27	30.0	M24 x 1.0	4.5	24	○
GEC.4S.240.LC	4B	27	30.0	M25 x 1.0	4.5	27	○
GEC.4K.241.LC	4K	32	35.5	M30 x 1.0	5.0	36	○
GEC.5S.240.LC	5B	37	41.0	M35 x 1.0	5.0	37	○

● Material: Chrome-plated brass (Ni 3 µm + Cr 0.3 µm)

Note: 3B, 3K, 4B, 4K, 5B and 5K series fixed and free receptacles for back panel mounting are always delivered with a conical nut. To order this accessory separately, use the part numbers in the table above.

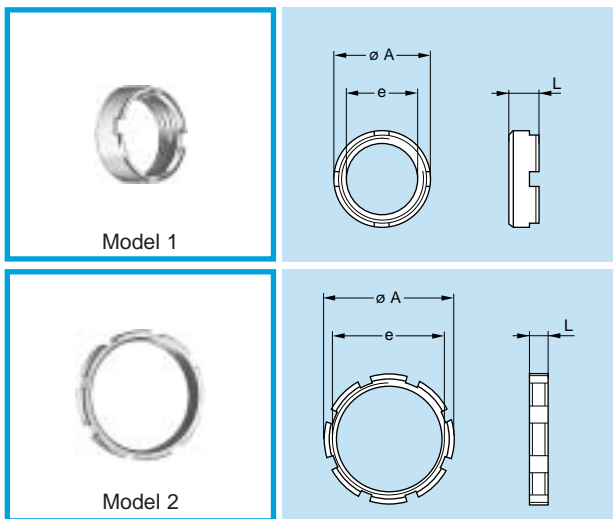

GEB Round nuts

Part number	Series	Model	Dimensions (mm)			Availability
			A	e	L	
GEB.00.240.LN	00	1	9.0	M7 x 0.50	4.0	○
GEB.0S.240.LN	0B	1	11.0	M9 x 0.60	4.0	○
GEB.2S.240.LN	2B	1	18.0	M15 x 1.00	5.5	○
GEB.3S.240.LN	3B	1	22.0	M18 x 1.00	5.5	○
GEB.4S.240.LN	4B	1	28.0	M25 x 1.00	6.0	○
GEB.5S.240.LN	5B	2	40.0	M35 x 1.00	8.0	○
GEB.5E.240.LN	5K	2	54.0	M45 x 1.50	8.0	○

Note: 5B and 5K series receptacles are always supplied with model 2 round nuts. To order this accessory separately, use the part numbers in the table above.

● Material: Nickel-plated brass (3 µm)

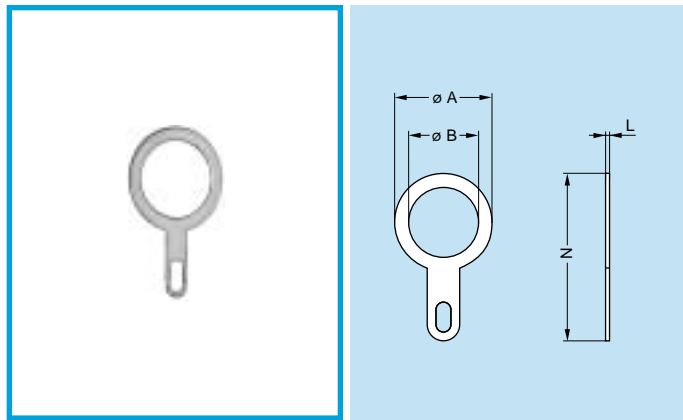

GCA Grounding lugs

Part number	Series	Dimensions (mm)				Availability
		A	B	L	N	
GCA.00.255.LT	00	9.5	7.1	0.4	18.2	●
GCA.0S.255.LT	0B	13.0	9.1	0.4	22.0	●
GCA.0E.255.LT	0K	17.0	14.1	0.5	27.5	○
GCA.2S.255.LT	2B	20.0	15.2	0.5	32.0	●
GCA.2E.255.LT	2K	25.0	20.2	0.5	39.0	○
GCA.3S.255.LT	3B	25.0	18.2	0.5	39.0	○
GCA.4S.255.LT	4B	35.0	25.6	0.6	50.0	○
GCA.4E.255.LT	4K	35.0	30.6	0.6	50.0	○
GCA.5S.255.LT	5B	42.0	35.1	0.7	57.5	○

- Material: CuSnZn plated brass (2 µm)

● Tooling

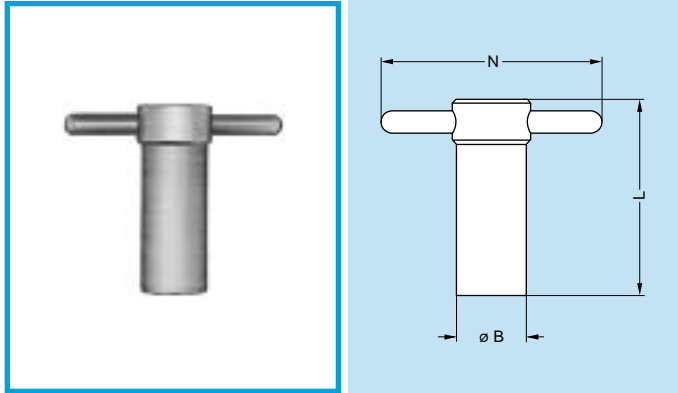

DCG Wrench for hexagonal nuts

Part number	Series	Dim. (mm)			Part number of the nut
		B	L	N	
DCG.91.149.0TN	00	14	40	50	GEA.00.240.LN
DCG.91.161.1TN	0B	16	45	52	GEA.0S.240.LN
DCG.91.231.7TN	2B	23	62	68	GEA.2S.240.LN
DCG.91.282.2TN	3B	28	76	73	GEA.3S.240.LN

● Material: Blackened steel

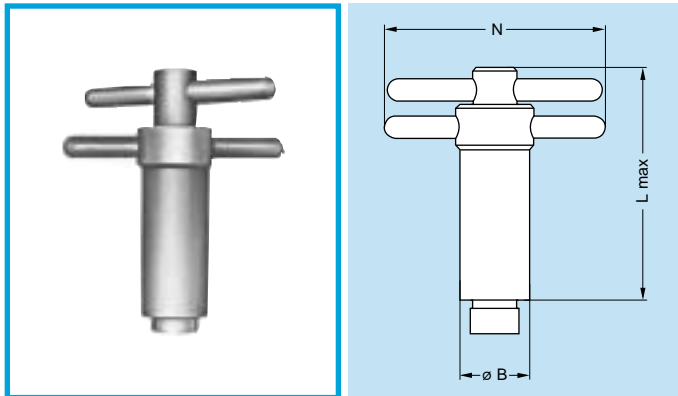

DCA Wrench for hexagonal nuts, with alignment of the receptacles by the flats

Part number	Series	Dim. (mm)			Part number of the nut
		B	L	N	
DCA.91.149.0TN	00	14	65	50	GEA.00.240.LN
DCA.91.161.1TN	0B	16	73	52	GEA.0S.240.LN
DCA.91.231.7TN	2B	23	100	68	GEA.2S.240.LN
DCA.91.282.2TN	3B	28	120	73	GEA.3S.240.LN

● Material: Blackened steel

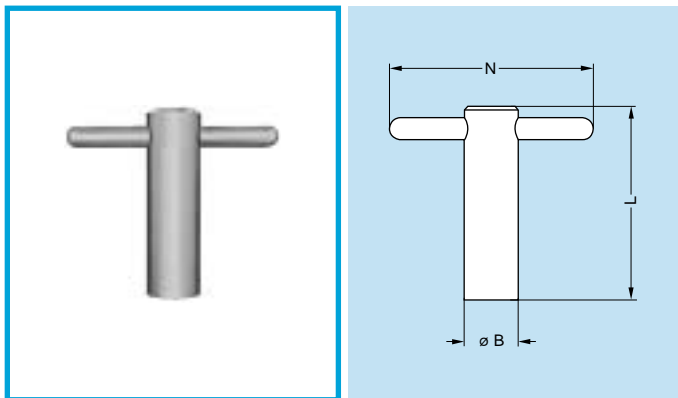

DCB Spanner type wrench for Model 1 round nuts

Part number	Series	Dim. (mm)			Part number of the nut
		B	L	N	
DCB.91.119.0TN	00	11	40	50	GEB.00.240.LN
DCB.91.131.1TN	0B	13	45	50	GEB.0S.240.LN
DCB.91.201.8TN	2B	20	62	65	GEB.2S.240.LN
DCB.91.242.2TN	3B	24	76	70	GEB.3S.240.LN

● Material: Blackened steel

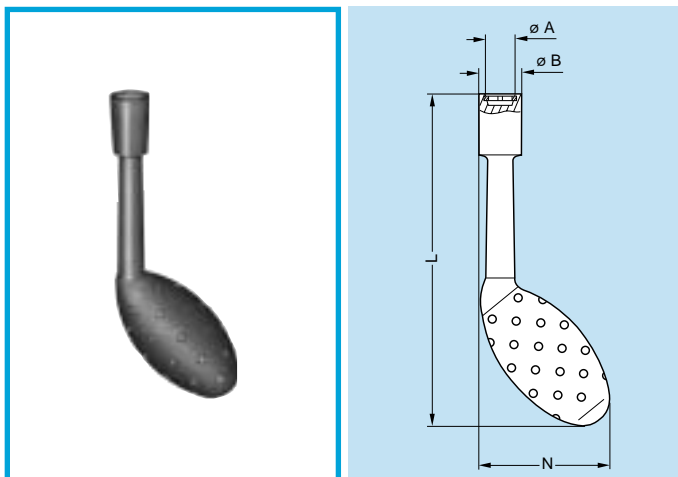

DCH Wrench for conical nut

Part number	Series	Dimensions (mm)				Part number of the nut
		A	B	L	N	
DCH.91.101.PN	00	10.1	12.8	124	48.3	GEC.00.240.LC
DCH.91.121.PN	0B	12.1	14.8	124	49.3	GEC.0S.240.LC
DCH.91.201.PN	2B	20.1	22.8	129	53.5	GEC.2S.240.LC

● Material: Dark grey polyurethane

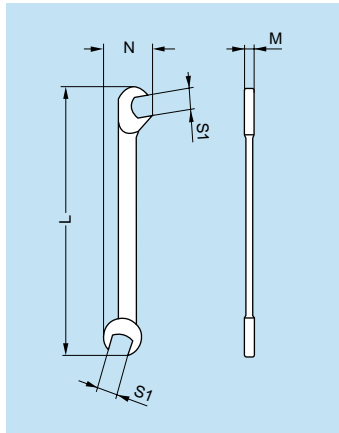

DCP Flat wrench for collet nut

Part number	Series	Dimensions (mm)			
		L	M	N	S1
DCP.99.045.TC	00	70	2	10.5	4.5
DCP.99.050.TC	00	78	2	12.6	5.0
DCP.99.055.TC	00	78	2	12.6	5.5
DCP.99.060.TC	00	78	2	12.6	6.0

- Material: Chrome-plated steel

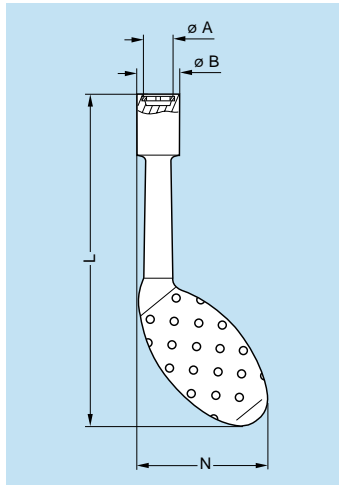

DCH Wrench for notched nuts

Part number	Series	Dimensions (mm)				Part number of the nut
		A	B	L	N	
DCH.91.101.PA	00	10.1	12.8	124	48.3	GEG.00.240.LC
DCH.91.121.PA	0B	12.1	14.8	124	49.3	GEG.0S.240.LC
DCH.91.181.PA	0K	18.1	22.8	129	53.1	GEG.0E.240.LC
DCH.91.201.PA	2B	20.1	22.8	129	53.5	GEG.2S.240.LC
DCH.91.251.PA	2K	25.1	32.8	134	55.5	GEG.2E.240.LC

- Material: Blue polyurethane

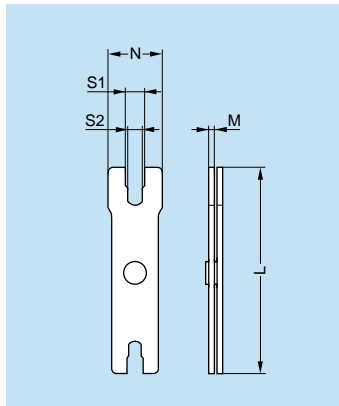

DCP Wrench for tightening collet nut

Part number	Series	Dimensions (mm)				
		L	M	N	S1	S2
DCP.91.001.TN	0B	95	2.5	21	8.1	7.1
DCP.91.023.TN	2B-2K	115	3.0	30	13.1	12.1
	3B-3K	115	3.0	35	15.1	14.1
DCP.91.045.TN	4B	130	3.5	40	21.2	20.2
	5B	130	3.5	45	31.2	30.2

- Material: Blackened steel

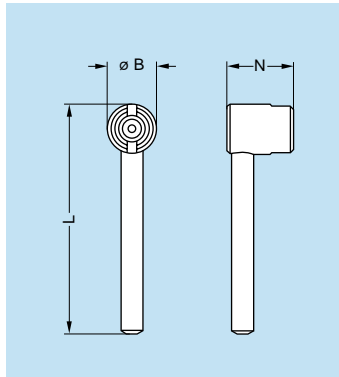

DCL Wrench for securing straight plug with two latching tabs while tightening collet nut

Part number	Series	Dimensions (mm)		
		B	L	N
DCL.91.105.0TK	00	10	45	13.5

- Material: Blackened steel

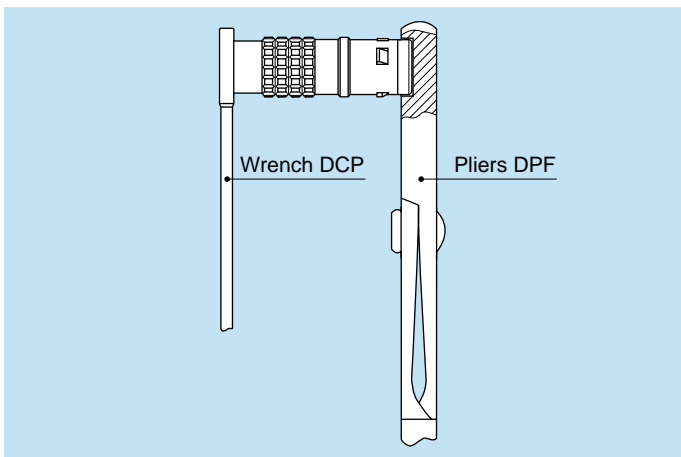
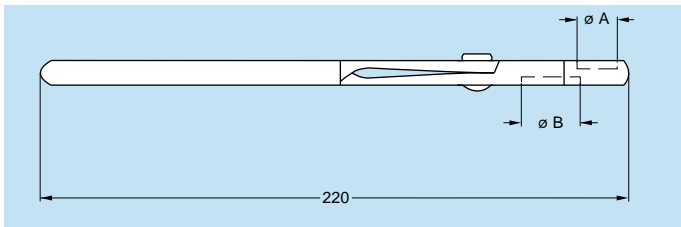

DPF Pliers for assembling plugs (series K)

Part number	Series	Dimensions (mm)	
		A	B
DPF.91.001.TA	0K	10	–
DPF.91.023.TA	2K	15	–
	3K	–	18

Example for use

The plug end must be held in the pliers while the nut is tightened with the wrench.



DTA Taps

Part number	Series	Thread
DTA.99.700.5Z	00	M7 x 0.5
DTA.99.900.6Z	0B	M9 x 0.6

● Crimping Tools for Electrical Contacts

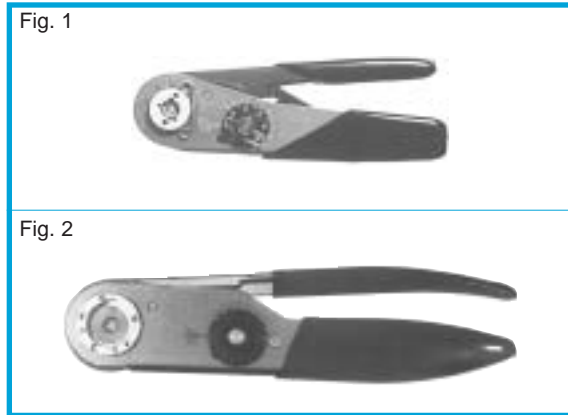

Manual crimping tools

Supplier	Part number	
	contact ø 0.7-0.9-1.3 (Fig. 1)	contact ø 1.6-2.0 (Fig. 2)
LEMO	DPC.91.701.V ¹⁾	DPC.91.101.A ²⁾
DANIELS	MH860 ¹⁾	AF8 ²⁾
BALMAR	23-000	55-000
BUCHANAN	616336 ¹⁾	615708 ²⁾

¹⁾ According to specification MIL-C-22520/7-01.

²⁾ According to specification MIL-C-22520/1-01.

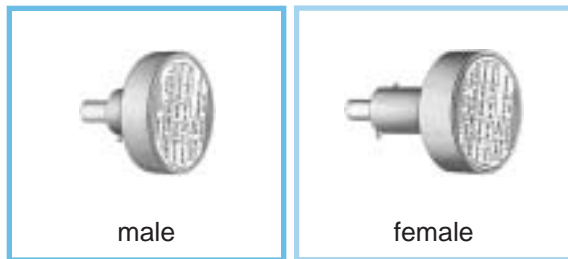

DCE Positioners for crimp contacts ø 0.7, 0.9 and 1.3 mm

These positioners are suitable for use with manual crimping tool according to the MIL-C-22520/7-01 standard.

	Connector				Positioners part number	
	Type		ø Contact	Conductor AWG	For male contact	For female contact
	F1	F2				
2B 2K	96A	92A	0.9	20-22-24	DCE.91.092.BVC	DCE.91.092.BVM
	96C	92C				
	96E	92E	0.7	22-24-26	DCE.91.072.BVC	DCE.91.072.BVM
	96J	92J				
3B 3K	97C	93B	0.9	20-22-24	DCE.91.093.BVC	DCE.91.093.BVM
	97E	93E				
	–	87E	0.7	22-24-26	DCE.91.073.BVC	DCE.91.073.BVM
	97J	93J				
	97R	93R				
	96X	92X				
–	87R					
4B 4K	–	95D	1.3	18-20	DCE.91.134.BVC	DCE.91.134.BVM
	–	93E	1.3 ¹⁾	18-20	DCE.91.133.BVCY	DCE.91.133.BVM
	–		0.9	20-22-24	DCE.91.094.BVC	DCE.91.094.BVM
	97F	–	1.3	18-20	DCE.91.134.BVC	DCE.91.134.BVM
			0.9	20-22-24	DCE.91.094.BVC	DCE.91.094.BVM
	97R	93R	0.9	20-22-24	DCE.91.094.BVC	DCE.91.094.BVM
	97L	93L				
	98L	94L	0.7	22-24-26	DCE.91.074.BVC	DCE.91.074.BVM
	97T	93T				
	–	88E				
99H	–					
98E	94E					

Note: ¹⁾ Arrangement with special contact length, special positioners are required.



DCE Turrets for crimp contacts ø 1.6 and 2.0 mm

These turrets are suitable for use with manual crimping tool according to the MIL-C-22520/1-01 standard.

	Connector				Turret part number	
	Type		ø Contact	Conductor AWG	For male contact	For female contact
	F1	F2				
5B 5K	–	94B	2.0	12-14-16	DCE.91.205.BVCM	DCE.91.205.BVCM
	–	956	2.0 ¹⁾	12-14-16	DCE.91.203.BVCM	DCE.91.204.BVCM
			1.6 ¹⁾	14-16-18	DCE.91.164.BVCM	DCE.91.162.BVCM
	–	90C	1.6 ¹⁾	14-16-18		

Note: ¹⁾ Arrangement with special contact length, turret from another series are required.

Note: A wide variation of strand number and diameter combinations are quoted as being AWG, some of which do not have a large enough cross section to guarantee a crimp as per either MIL-C-22520/1 or /7-01. Our technical department is at your disposal to study and propose a solution to all your specific problems.

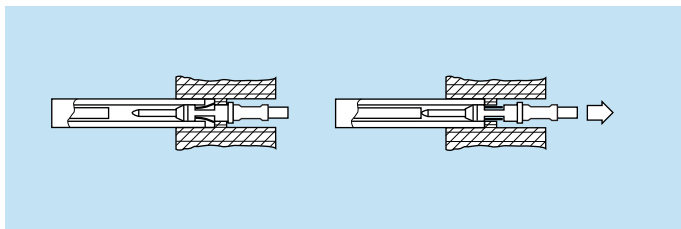
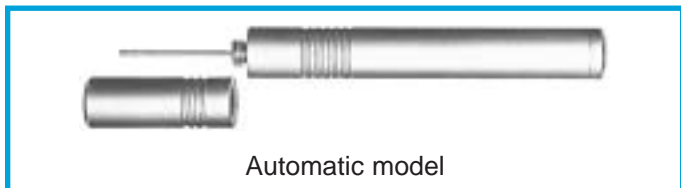
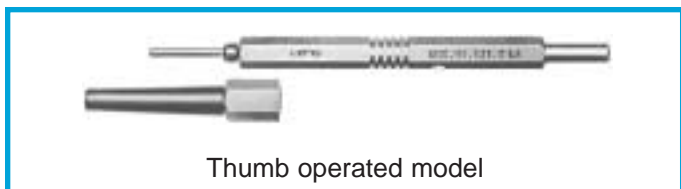

DCC Extraction tools for crimp contacts

	FO Contact		ø A Contact	Extractor	
	Types			Thumb operated model	Automatic model
	F1	F2			
2B 2K	96A	92A	0.9	DCC.91.090.5LA	DCF.91.090.2LT
	96C	92C	0.7	DCC.91.070.5LA	DCF.91.070.2LT
	96E	92E			
	96J	92J			
3B 3K	97C	93B	0.9	DCC.91.090.5LA	DCF.91.093.5LT
	97E	93E			
	-	87E	0.7	DCC.91.070.5LA	DCF.91.073.5LT
	97J	93J			
	97R	93R			
	96X	92X			
-	87R				
4B 4K	-	95D	1.3	DCC.91.131.5LA	DCF.91.133.5LT
	-	93E	1.3	DCC.91.131.5LA	DCF.91.133.5LT
			0.9	DCC.91.090.5LA	DCF.91.093.5LT
	97F	-	1.3	DCC.91.131.5LA	DCF.91.133.5LT
			0.9	DCC.91.090.5LA	DCF.91.093.5LT
	97R	93R	0.9	DCC.91.090.5LA	DCF.91.093.5LT
	97L	93L			
	98L	94L	0.7	DCC.91.070.5LA	DCF.91.073.5LT
	97T	93T			
	-	88E			
	99H	-			
	98E	94E			
5B 5K	-	94B	2.0	DCC.91.202.5LA	DCF.91.203.5LT
	-	956	2.0	DCC.91.202.5LA	DCF.91.203.5LT
			1.6	DCC.91.162.5LA	DCF.91.163.5LT
	-	90C	1.6	DCC.91.162.5LA	DCF.91.163.5LT

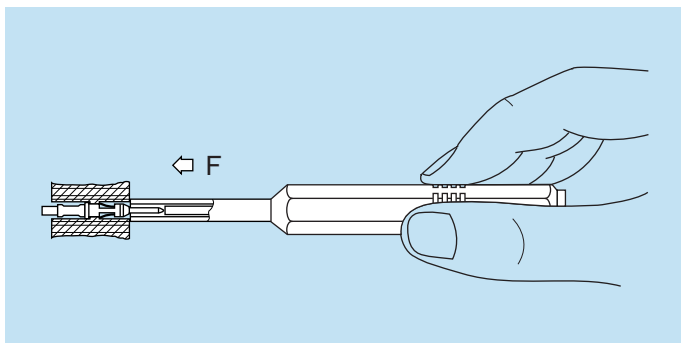
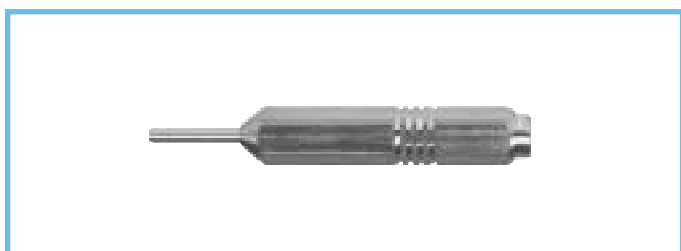

DCK Retention testing tools for crimp contacts ø 0.7, 0.9 and 1.3 mm

Contact ø A	Test force (N)	Testing tool part number	
		For male contact	For female contact
0.7	14	DCK.91.071.4LRC	DCK.91.071.4LRM
0.9	14	DCK.91.091.4LRC	DCK.91.091.4LRM
1.3	25	DCK.91.132.5LRC	DCK.91.132.5LRM

● Tools for type C Coaxial Contacts

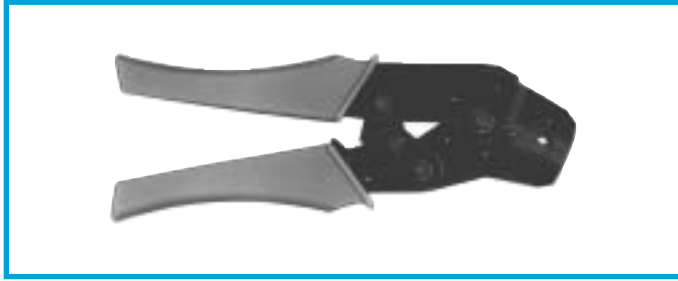

DPE Crimping tool with die

Part number	Cable group
DPE.99.103.1K	2
DPE.99.103.8K	1, 3

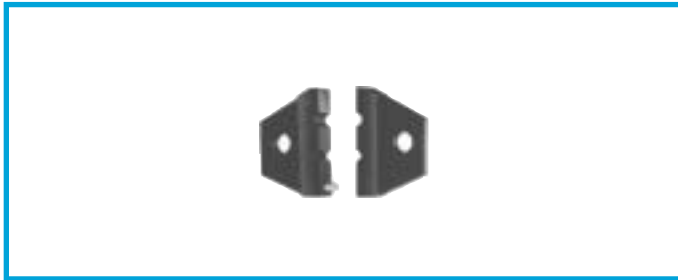

DPN Dies

Part number	Cable group	Die dimensions					
		For contacts			For shield		
		A	B	L	A	B	
DPN.99.103.1K	2	1.09	0.77	2.0	3.10	2.70	
DPN.99.103.8K	1, 3	1.09	0.77	2.0	3.80	3.30	

- Die material: Blackened steel

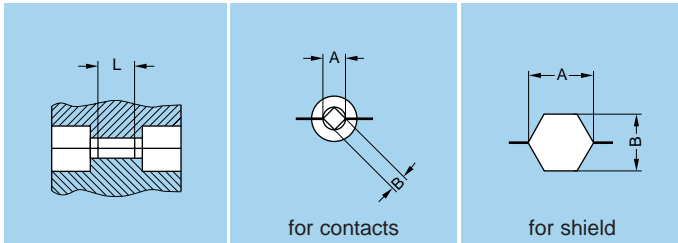

DCC Extractors

Part number	Cable group
DCC.91.384.5LA	1, 2, 3

● Fiber Optic Tooling

LEMO offers a complete range of tools for fiber optic connector cable assembly. Some tools are specific to each fiber optic contact type. When selecting necessary tooling, it is important to correctly identify the contact type used in the selected product.



DRV Complete workstation for fiber optic contact

Description

Comprehensive range of tools for terminating both single-mode and multi-mode fibers. Detachable termination case lid for use as polishing platform during field termination.

Rugged but aesthetically pleasing termination case which is ideal for field use or in-house terminations. Curing oven and inspection microscope may be ordered separately.

Part number	Contact type
DRV.91.CF2.PN	F2, F4

Workstation Contents

Part Number	Description	Quantity	Number
WST.BT.175.55PT	Plastic box	1	1
WST.BR.150.8AC	Tweezers	1	2
WST.CH.252.5SR	Lint-free Cloth	1	3
WST.CS.125.CE	Kevlar cutters	1	4
WST.CO.020.52	Cotton bud (sachet of 20 pcs)	1	5
WST.DS.290.PT	Alcohol dispenser (supplied empty)	1	6
DCC.91.312.5LA	Extraction tool for F1 and F2 contacts	1	7
DCS.91.G20.0C	Microscope adapter for F2 and F4 cont.	1	8
WST.ME.354.8R	Epoxy mixer and pad	1	9
DOC.FO.CF2.0000	Terminating instructions for F2 contacts	1	10
WST.OU.135.10SZ	Fiber scribe	1	11
DCS.91.F24.LC	Polishing tool for F2 and F4 contacts	1	12
WST.OU.452.5MN	Large cable stripper	1	13
WST.PA.105.5525	Cleaning tissues	1	14
WST.PA.012.AOJ	Lapping film 12µm (yellow)	20	15
WST.PA.005.AOM	Lapping film 5µm (brown)	20	16
WST.PA.001.AOV	Lapping film 1µm (green)	20	17
WST.PN.210.AS	Armoured cable cutter	1	18
WST.PN.145.AR	Cable cutter	1	19
WST.PN.103.0PG	Outer jacket stripper	1	20
WST.PN.203.CR	Buffer coating stripping tool	1	21
WST.PN.102.3CR	Primary coat stripper	1	22
DPE.99.524.337K	Crimp tool	1	23
WST.PL.322.5PT	Polishing platform	1	24
WST.RE.353.EPO	Epoxy resin + safety instructions	10	25
WST.SE.305.8PH	Syringe with needle	10	26
WST.TU.191.LN	Fiber shield for F2 and F4 contacts	4	27
WST.RG.150.AZ	Steel rule 6"	1	28
WST.SY.135.PA	Fiber length marking pen	1	29
WST.CS.155.AZ	Scissors	1	30

Note: The interior of the case is fitted with pre-formed plastic foam to provide secure storage of the tools.

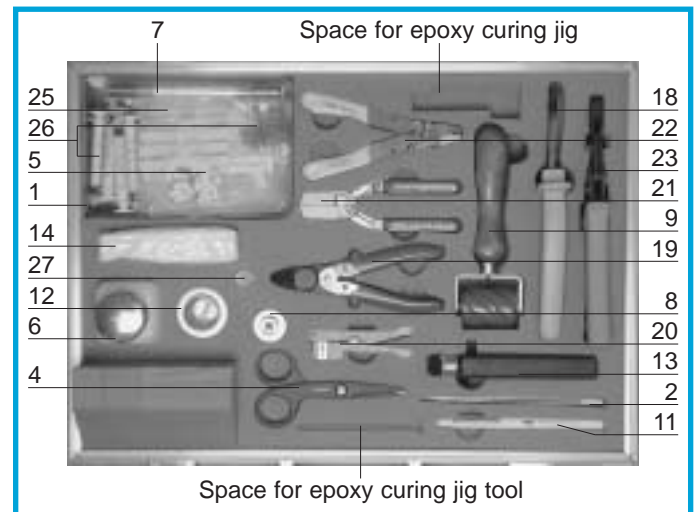
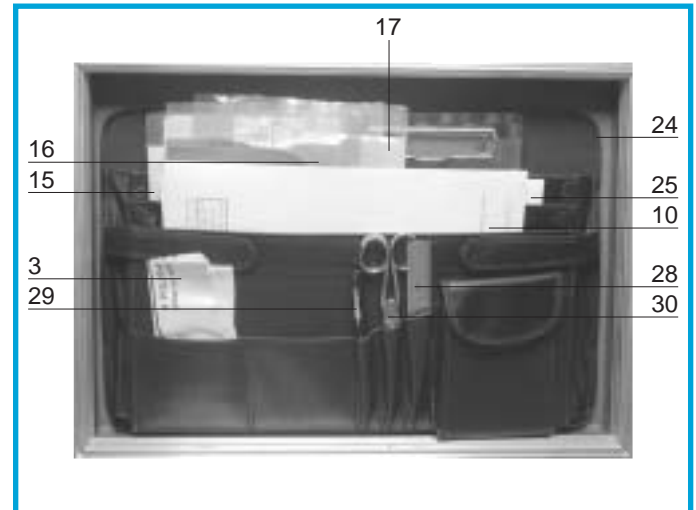



DPE Crimping tool for fiber optic contact

Description

Crimping tool for capturing KEVLAR® strand on contact body

Part number	Contact type
DPE.99.524.337K ¹⁾	F1, F2, F3, F4

Note: ¹⁾ Included in the LEMO F2 workstation.

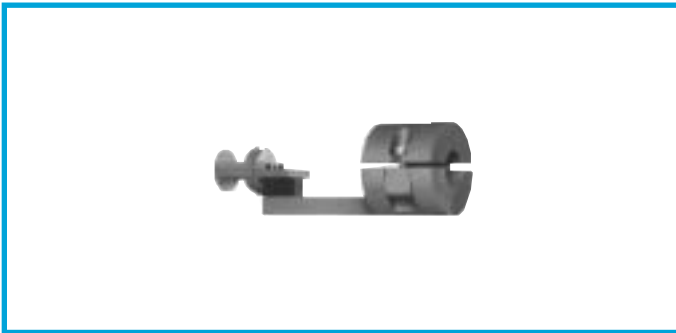
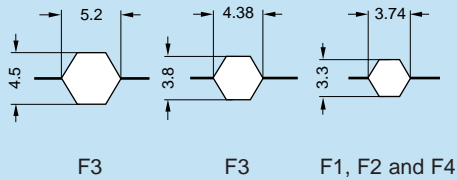

DCS Epoxy curing jig

Description

Curing positioning jig specifically designed to ease assembly of the 3K.93C series with associated camera cable

Part number	Contact type
DCS.91.F12.3LA	F2



WST Epoxy curing oven

Description

Oven for assisting in curing epoxy

Part number	Voltage	Contact type
WST.FR.220.VA	220 volts	F1, F2, F3, F4
WST.FR.110.VA	110 volts	



DCS Polishing tool for fiber optic contacts

Description

Precision spring loaded tool for polishing terminated fiber optic contacts.

Part number	Contact type
DCS.91.F13.LC	F1, F3
DCS.91.F24.LC ¹⁾	F2, F4

Note: ¹⁾ Included in the LEMO F2 workstation.



WST Fiber Inspection Microscope

Description

Microscope to assist in viewing termination operations and verifying fiber end finish. See adaptor below.

Part number	Contact type
WST.FB.G10.4N	F1, F2, F3, F4

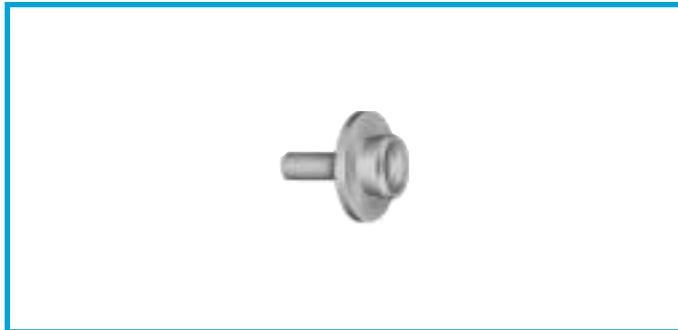

DCS Microscope adaptor for fiber optic contacts

Description

Adaptor for final inspection of fiber optic contacts. To be used with microscope WST.FB.G10.4N

Part number	Contact type
DCS.91.G24.0C	F1, F3
DCS.91.G20.0C ¹⁾	F2, F4

Note: ¹⁾ Included in the LEMO F2 workstation.

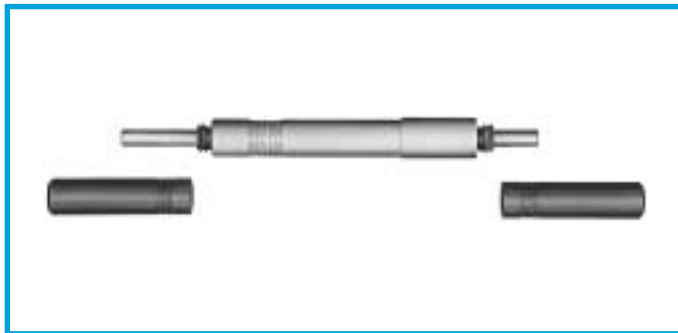

DCC Extractor for fiber optic contact

Description

One side of the tool is the extractor for the F1 or F2 contact. The other threaded end is for installation/extraction of the F2 contact alignment device

Part number	Contact type
DCC.91.312.5LA ¹⁾	F1, F2

Note: ¹⁾ Included in the LEMO F2 workstation.



DCS F2 contact alignment device installation/extraction tool

Description

Simple tool with two threaded end for installation/extraction of the F2 contact alignment device

Part number	Contact type
DCS.F2.035.PN	F2



DCC F4 contact alignment device extraction tool

Description

This tool is for extraction/reinstallation of the F4 contact alignment device. It is necessary for contact cleaning only

Part number	Contact type
DCC.F4.125.7LA	F4

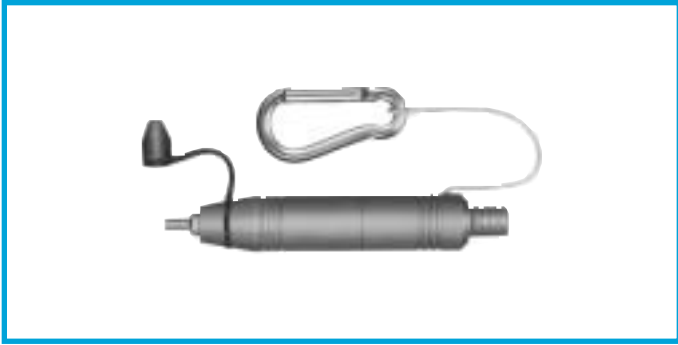

DCS Cleaning tool

Description

Used for maintenance cleaning. The tool is made with an alcohol spongy reservoir (supplied empty). 16 dry cotton buds are included. The threaded end allows extraction/reinstallation of the F2 contact alignment device.

Part number	Contact type
DCS.91.F23.LA	F2



WST Cleaning kit

Description

Kit that includes 2 cotton buds one of them moistened with alcohol

Part number	Contact type
WST.KI.125.34	F1, F2, F3, F4

Cable fixing

Cable fixing onto LEMO connectors is determined by the cable characteristics and the connector model. This is achieved either with a cable collet system, by epoxy into a cable adapter or by hexagonal crimping (MIL-C-22520F).

Material and Treatment

Component	Material (Standard)	Surface Treatment (µm)	
		Cu	Ni
Center piece	Brass (UNS C 38500)	0.5	3
Collet	Brass (UNS C 38500)	0.5	3
Crimp ferrule or ring	Copper (UNS C 18700)	0.5	3
Reducer	Brass (UNS C 38500)	0.5	3
Reducing cone	Brass (UNS C 38500)	0.5	3
Earthing cone	Brass (UNS C 38500)	0.5	3
Metal washer	Brass (UNS C 38500)	0.5	3
Cable adapter	Brass (UNS C 38500)	0.5	3
Support tube	Stainless steel (AISI 304)	-	
Anchor	Stainless steel (AISI 303)	-	
Earthing body	Brass (UNS C 38500)	0.5	3
Gasket or o-ring	Silicone MQ/MVQ	-	
	FPM (Viton®)		

Notes:
Standards for surface treatment are as follows: Nickel-plated: FS QQ-N-290A.

Cable fixing for 00 and 0B series

In this series of single fiber connectors the fiber optic cables are held onto the contacts using the hexagonal crimping technique. The cable strength member (aramid yarn) is retained between the knurled section of the contact ④ and the crimp ferrule ②. The support tube ⑤ is used to protect the delicate optical fiber from the crimping load. Buffer coated fibers are retained into the fiber optic contact using an epoxy technique (Type T).

The fiber optic contact is retained into the connector with the collet nut ①.

00 Series

Type E fixing (crimp)

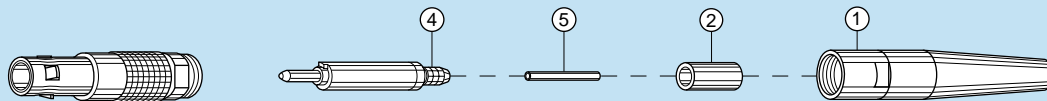

00 Series

Type T fixing (epoxy)

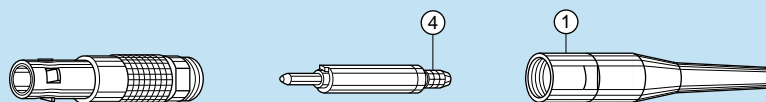

0B Series

Type E fixing (crimp)

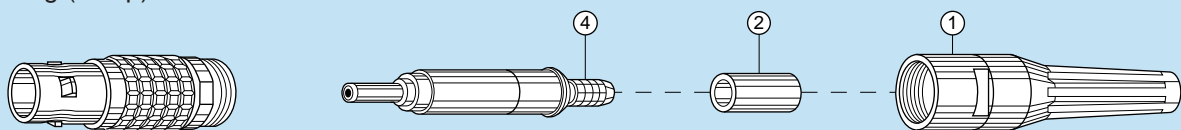

Cable fixing for 0K series

In this series of single fiber the fiber optic cable is held onto the contact using the hexagonal crimping technique. The cable strength member (aramid yarn) is retained between the knurled section of the contact ④ and the crimp ferrule ②. Then the contact is inserted into the adapter ⑤ and is retained because of its special shape. The adapter with its fiber optic contact is retained into the connector with the collet nut ①.

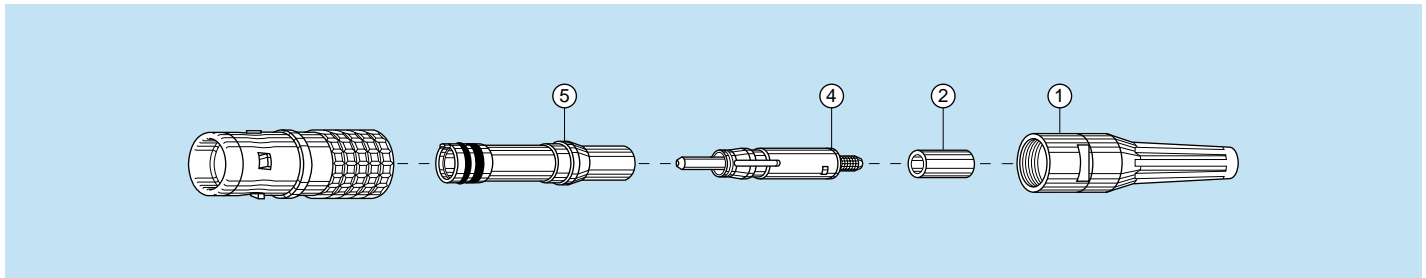

Cable clamping for 2B-3B-4B and 5B series

Type D cable clamping

This is the standard cable clamping for 2B, 3B, 4B, and 5B series. Two split insert carriers ④ position the insulator into the connector and a collet ② which is compressed by the collet nut ① ensures a good grip onto the cable. When assembling the connector, the cable shield is clamped between the split insert carrier and the collet.

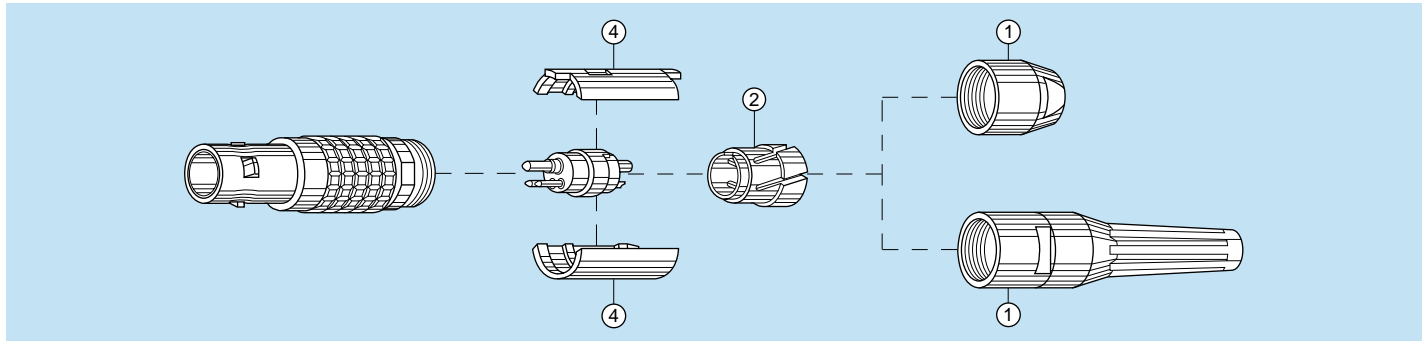

Type M cable clamping

This clamping system is adapted to cables with a diameter smaller than the smallest diameter specified for each series. It includes a reducer ⑫, a collet of a smaller series ② and a reducing cone ⑪. These parts have the same function as the D type collet.

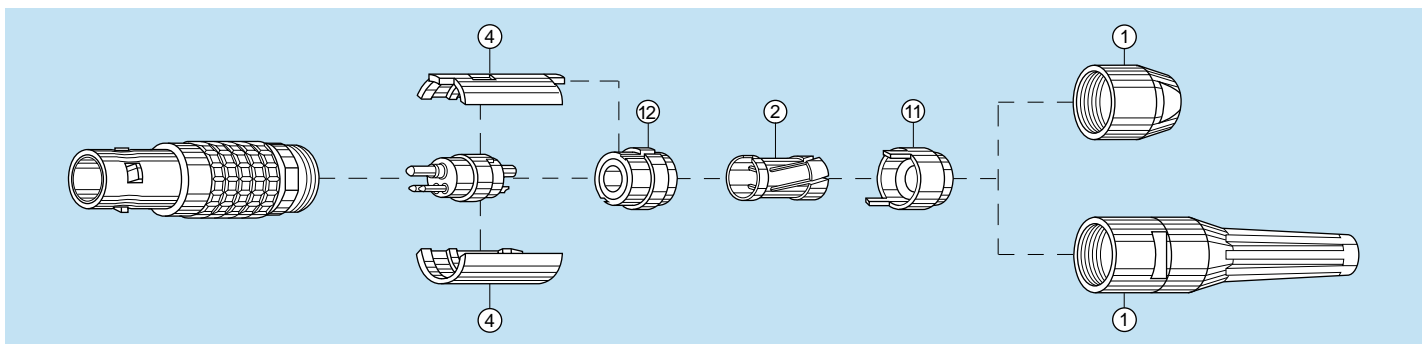

Cable fixing for 2K-3K-4K and 5K series

Type T clamping

In the watertight series the clamping system is made of a cable adapter ② which is fixed on the cable by epoxy. This solution offers superior captivation of the cable strength member (aramid yarn) and is fully watertight. The adapter is completed by a sealing o-ring ③. The insulator is positioned into the cable adapter and is correctly oriented by the split insert carrier ④. The system is retained into the connector by the collet nut with its bend relief.

For some specific cables (3K.93C series) an anchor ⑥ is installed to allow retention of the cable center steel strength member. For screened cable, the shield can be soldered to the cable adapter front section.

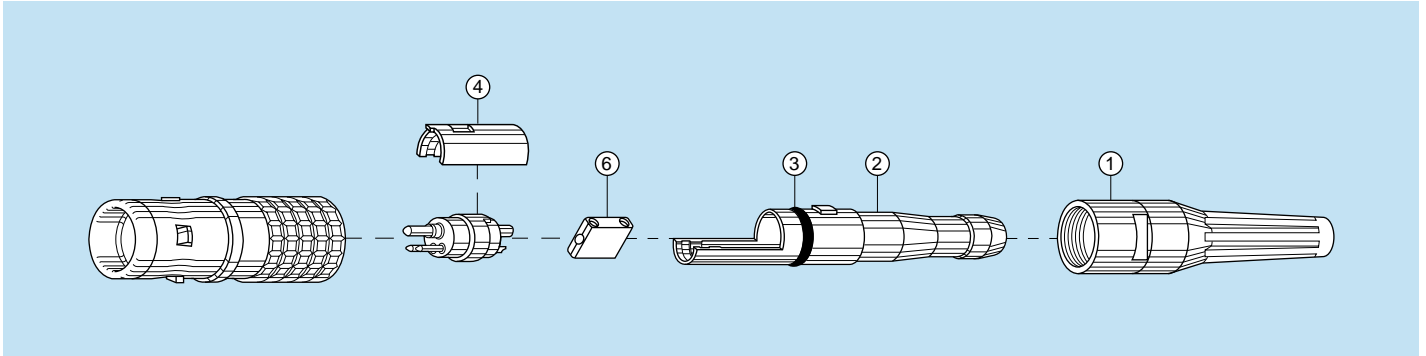

Cable clamping for the model FUW and PUW of the 3K.93C series

Type C clamping

For these 2 models the clamping is made of a collet ② located into the extender ⑩ and compressed by the collet nut ① to ensure a good grip onto the cable. A gasket, inside of the collet, provides sealing onto cable jacket. Additional sealing is made with epoxy. To guarantee enhanced screen efficiency the shield of the cable is retained between the knurled section of the earthing body ⑦ and the crimp ring ⑤. The insulator is positioned into the two insert carrier ④. The anchor ⑥ is installed to allow retention of the cable center steel strength member.

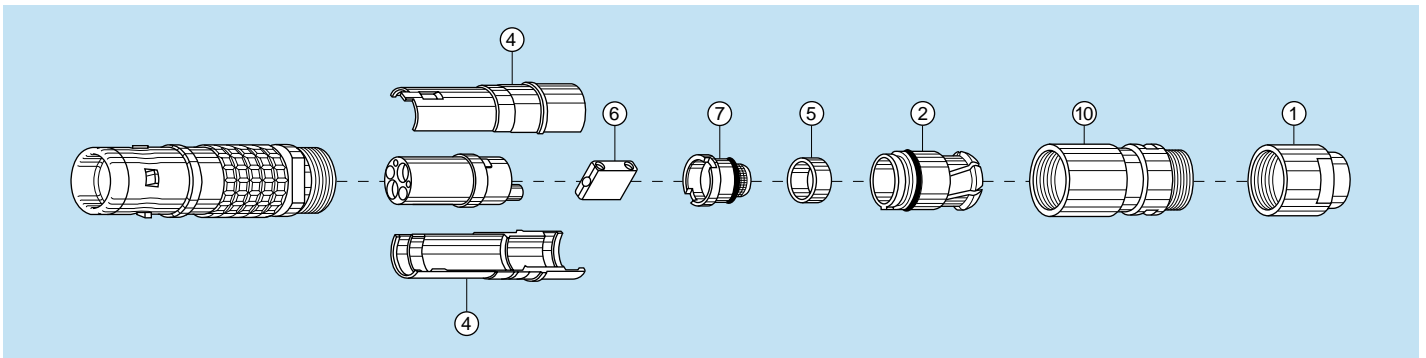

Maximum metal collet nut tightening torque

	Series										
	00	0B	0K	2B	3B	4B	5B	2K	3K	4K	5K
Torque (Nm)	0.25	0.5	0.7	2.5	4	7	10	2	3	5	8

Maximum plastic collet nut tightening torque ¹⁾

	Series		
	2B	3B	4B
Torque (Nm)	0.50	1.00	1.50

Note: ¹⁾ For applications subject to strong vibration, we recommend fixing the collet nut with epoxy resin.

Preferred fiber optic cable types

The preferred and very common cable construction for use with LEMO connectors are shown below.

- Simplex semi-tight jacket cables between 2 and 3 mm in diameter and have straight lay Kevlar® reinforcement (see fig. 1).
- 900 micron plastic buffered fibers (see fig. 2).
- Multiway «break-out» cables which have additionnal overall straight lay Kevlar® to provide cable pull resistance (see fig. 3).
- Multiway «premise» cables with 900 micron plastic buffered fibers and additionnal overall straight lay Kevlar® to provide cable pull resistance (see fig. 4).

Fig. 1



Fig. 2



Fig. 3

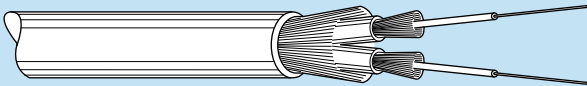
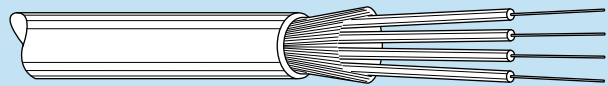

Fig. 4



For other cable construction it is recommended that you contact us directly for advice on their suitability for termination onto LEMO connectors.

● Technical Tables

Table of Wire Gauges

AWG	Construction		ø wire max		Wire section	
	Strand nb	AWG/strand	(mm)	(in)	(mm ²)	(sq in)
4	133	25	6.9596	0.274	21.5925	0.0335
6	133	27	5.5118	0.217	13.5885	0.0211
8	168	30	4.4450	0.175	8.5127	0.0132
8	133	29	4.3942	0.173	8.6053	0.0133
10	105	30	3.3020	0.13	5.3204	0.0082
10	37	26	2.9210	0.115	4.7397	0.0073
10	1	10	2.6162	0.103	5.2614	0.0082
12	65	30	2.5146	0.099	3.2936	0.0051
12	37	28	2.3114	0.091	2.9765	0.0046
12	19	25	2.3622	0.093	3.0847	0.0048
12 ¹⁾	7	20	2.5400	0.1	3.6321	0.0056
12	1	12	2.0828	0.082	3.3081	0.0051
14	41	30	2.0574	0.081	2.0775	0.0032
14	19	27	1.8542	0.073	1.9413	0.0030
14 ¹⁾	7	22	2.0828	0.082	2.2704	0.0035
14	1	14	1.6510	0.065	2.0820	0.0032
16 ¹⁾	65	34	1.5748	0.062	1.3072	0.0020
16	26	30	1.5748	0.062	1.3174	0.0020
16	19	29	1.4986	0.059	1.2293	0.0019
16 ¹⁾	7	24	1.5494	0.061	1.4330	0.0022
16	1	16	1.3208	0.052	1.3076	0.0020
18 ¹⁾	65	36	1.2700	0.05	0.8234	0.0013
18 ¹⁾	42	34	1.2700	0.05	0.8447	0.0013
18	19	30	1.3208	0.052	0.9627	0.0015
18	16	30	1.2954	0.051	0.8107	0.0013
18	7	26	1.2700	0.05	0.8967	0.0014
18	1	18	1.0414	0.041	0.8229	0.0013
20 ¹⁾	42	36	1.0160	0.04	0.5320	8.2 x 10 ⁻⁴
20	19	32	1.0414	0.041	0.6162	0.0010
20	10	30	1.0160	0.04	0.5067	7.9 x 10 ⁻⁴
20	7	28	0.9906	0.039	0.5631	8.7 x 10 ⁻⁴
20	1	20	0.8382	0.033	0.5189	8.0 x 10 ⁻⁴
22	19	34	0.8382	0.033	0.3821	5.9 x 10 ⁻⁴
22	7	30	0.7874	0.031	0.3547	5.5 x 10 ⁻⁴
22	1	22	0.6604	0.026	0.3243	5.0 x 10 ⁻⁴
24 ¹⁾	42	40	0.6604	0.026	0.2045	3.2 x 10 ⁻⁴
24	19	36	0.6858	0.027	0.2407	3.7 x 10 ⁻⁴
24	7	32	0.6350	0.025	0.2270	3.5 x 10 ⁻⁴
24	1	24	0.5588	0.022	0.2047	3.2 x 10 ⁻⁴
26	19	38	0.5588	0.022	0.1540	2.4 x 10 ⁻⁴
26	7	34	0.5080	0.02	0.1408	2.2 x 10 ⁻⁴
26	1	26	0.4318	0.017	0.1281	2.0 x 10 ⁻⁴
28 ¹⁾	19	40	0.4318	0.017	0.0925	1.4 x 10 ⁻⁴
28	7	36	0.4064	0.016	0.0887	1.4 x 10 ⁻⁴
28	1	28	0.3302	0.013	0.0804	1.2 x 10 ⁻⁴
30	7	38	0.3302	0.013	0.0568	8.8 x 10 ⁻⁵
30	1	30	0.2794	0.011	0.0507	7.9 x 10 ⁻⁵
32	7	40	0.2794	0.011	0.0341	5.3 x 10 ⁻⁵
32	1	32	0.2286	0.009	0.0324	5.0 x 10 ⁻⁵
34	1	34	0.1693	0.007	0.0201	3.1 x 10 ⁻⁵
36	1	36	0.127	0.005	0.0127	2.0 x 10 ⁻⁵
38	1	38	0.1016	0.004	0.0081	1.3 x 10 ⁻⁵
40	1	40	0.078	0.003	0.0049	7.5 x 10 ⁻⁶

Table of wire gauges according to IEC-228 standard

Conductor no x Ø (mm)	Max Ø (mm)	Max Ø (in)	Section (mm ²)	Section (sq in)
196 x 0.40	7.50	0.295	25.00	0.0387
7 x 2.14	6.10	0.240	25.00	0.0387
125 x 0.40	6.00	0.236	16.00	0.0248
7 x 1.72	4.90	0.192	16.00	0.0248
1 x 4.50	4.50	0.177	16.00	0.0248
80 x 0.40	4.70	0.155	10.00	0.0155
7 x 1.38	3.95	0.155	10.00	0.0155
1 x 3.60	3.60	0.141	10.00	0.0155
84 x 0.30	3.70	0.145	6.00	0.0093
7 x 1.50	3.15	0.124	6.00	0.0093
1 x 2.76	2.76	0.108	6.00	0.0093
56 x 0.30	2.80	0.110	4.00	0.0062
7 x 0.86	2.58	0.098	4.00	0.0062
1 x 2.25	2.25	0.082	4.00	0.0062
50 x 0.25	2.15	0.084	2.50	0.0038
7 x 0.68	2.04	0.080	2.50	0.0038
1 x 1.78	1.78	0.070	2.50	0.0038
30 x 0.25	1.60	0.062	1.50	0.0023
7 x 0.52	1.56	0.061	1.50	0.0023
1 x 1.14	1.40	0.055	1.50	0.0023
32 x 0.20	1.35	0.053	1.00	0.0015
7 x 0.43	1.29	0.050	1.00	0.0015
1 x 1.15	1.15	0.045	1.00	0.0015
42 x 0.15	1.20	0.047	0.75	0.0011
28 x 0.20	1.15	0.045	0.75	0.0011
1 x 1.0	1.00	0.039	0.75	0.0011
28 x 0.15	0.95	0.037	0.50	7.7 x 10 ⁻⁴
16 x 0.20	0.90	0.035	0.50	7.7 x 10 ⁻⁴
1 x 0.80	0.80	0.031	0.50	7.7 x 10 ⁻⁴
7 x 0.25	0.75	0.029	0.34	5.2 x 10 ⁻⁴
1 x 0.60	0.60	0.023	0.28	4.3 x 10 ⁻⁴
14 x 0.15	0.75	0.029	0.25	3.8 x 10 ⁻⁴
7 x 0.20	0.65	0.023	0.22	3.4 x 10 ⁻⁴
18 x 0.10	0.50	0.019	0.14	2.1 x 10 ⁻⁴
14 x 0.10	0.40	0.015	0.11	1.7 x 10 ⁻⁴
21 x 0.07	0.40	0.015	0.09	1.3 x 10 ⁻⁴
14 x 0.10	0.40	0.015	0.09	1.3 x 10 ⁻⁴

Note: 1) Not included in the standard

● Conversion Tables — millimeters/inches

(mm)	(in)	(mm)	(in)	(mm)	(in)	(mm)	(in)	(mm)	(in)	(mm)	(in)
0.02	0.0007	1.37	0.0539	3.90	0.1535	8.90	0.3504	16.00	0.6299	29.50	1.1614
0.03	0.0011	1.40	0.0551	4.00	0.1575	9.00	0.3543	16.10	0.6338	30.00	1.1811
0.10	0.0039	1.50	0.0590	4.36	0.1716	9.40	0.3701	17.00	0.6693	30.80	1.2125
0.16	0.0062	1.52	0.0598	4.50	0.1771	9.50	0.3740	17.50	0.6889	31.00	1.2204
0.18	0.0071	1.60	0.0629	5.00	0.1968	9.60	0.3779	17.80	0.7007	31.80	1.2519
0.20	0.0078	1.70	0.0669	5.08	0.1999	9.70	0.3818	18.00	0.7086	32.00	1.2598
0.30	0.0118	1.71	0.0673	5.20	0.2047	10.00	0.3937	18.20	0.7165	33.00	1.2992
0.40	0.0157	1.80	0.0708	5.37	0.2114	10.30	0.4055	18.50	0.7283	33.50	1.3188
0.48	0.0188	2.00	0.0787	5.50	0.2165	10.40	0.4094	19.00	0.7480	34.00	1.3385
0.50	0.0196	2.10	0.0826	5.80	0.2283	10.50	0.4134	19.50	0.7677	34.50	1.3582
0.51	0.0201	2.20	0.0866	6.00	0.2362	10.70	0.4212	20.00	0.7874	35.70	1.4055
0.54	0.0212	2.42	0.0953	6.20	0.2441	10.80	0.4252	20.50	0.8071	36.00	1.4173
0.60	0.0236	2.50	0.0984	6.30	0.2480	11.00	0.4331	20.60	0.8110	40.00	1.5748
0.70	0.0275	2.60	0.1023	6.40	0.2519	11.50	0.4527	21.00	0.8267	41.00	1.6141
0.80	0.0315	2.70	0.1063	6.50	0.2559	11.70	0.4606	21.50	0.8464	42.00	1.6535
0.86	0.0338	2.80	0.1102	6.80	0.2677	12.00	0.4724	21.80	0.8582	43.00	1.6929
0.87	0.0342	2.95	0.1161	7.00	0.2755	12.60	0.4961	22.00	0.8661	45.00	1.7716
0.90	0.0354	3.00	0.1181	7.10	0.2795	12.90	0.5078	23.00	0.9055	45.50	1.7913
0.91	0.0358	3.05	0.1201	7.40	0.2913	13.00	0.5118	23.80	0.9370	46.50	1.8307
0.95	0.0374	3.10	0.1220	7.50	0.2952	13.70	0.5393	24.00	0.9448	50.00	1.9685
1.00	0.0393	3.20	0.1259	8.00	0.3149	14.00	0.5512	25.00	0.9842	60.00	2.3622
1.21	0.0476	3.30	0.1299	8.30	0.3267	14.30	0.5629	25.50	1.0039	65.00	2.5590
1.29	0.0507	3.50	0.1378	8.60	0.3385	14.50	0.5708	26.00	1.0236	70.00	2.7559
1.30	0.0512	3.78	0.1488	8.70	0.3425	15.00	0.5905	28.00	1.1023	78.00	3.0708
1.32	0.0519	3.80	0.1496	8.80	0.3464	15.50	0.6102	28.50	1.1220	150.00	5.9055

● Terms and Conditions

- 1. Acceptance:** If Buyer's order contains written, printed or stamped provisions or conditions inconsistent with the written, printed or stamped provisions of this Agreement attached hereto, the provisions and conditions of this Agreement shall prevail. Buyer shall contact LEMO USA within 10 days of receipt of LEMO USA Terms and Conditions if any objection is raised. Failure of Buyer to timely object shall be deemed an acceptance by Buyer of LEMO USA's Terms and Conditions. If a timely objection is raised by the Buyer to the LEMO USA Terms and Conditions, the order(s) will not be entered until agreement in writing is reached. All orders are subject to acceptance by Seller. Seller's acceptance is expressly conditional upon Buyer's acceptance of LEMO USA Terms and Conditions.
- 2. Pricing:** Prices are based on continuous manufacture rates of delivery specified. Buyer will be charged any direct additional cost to which Seller is put by reason of any interruption of production due to Buyer's request, act or default.
- 3. Applicable Law:** Purchase Order is subject to the applicable provisions of the Uniform Commercial Code, under the laws of the State of California.
- 4. Buyer's Liability:** Buyer is liable for all costs associated with completed units, shipped or unshipped, labor and materials on work in process, and raw materials on hand and/or specific to Buyer's Order and all reasonable direct damages, for lead time specified in advance of requested date of cancellation.
- 5. License:** The submission of a quotation or order acknowledgment does not grant or imply a license under any patents now owned or controlled by Seller, or which may become owned or controlled by Seller.
- 6. Buyer's Default:** In the event Buyer cancels the contract embodied by Buyer's Order and this acceptance thereof, in whole or in part, or such contract is canceled by Seller because of default by the Buyer, the Buyer shall pay Seller by reason of such cancellation or default for reasonable direct damages sustained, including costs associated with completed units, shipped or unshipped, labor and materials on work in process, and raw materials on hand and/or specific to Buyer's Order and all reasonable direct damages, for lead time specified in advance of requested date of cancellation, at the current price applicable to the total quantity ordered at the time of default. Notwithstanding the foregoing, if item or items ordered are NON-CANCELABLE/NON-RETURNABLE, the Buyer shall purchase 100% of quantity ordered.

In the event Seller does not meet the confirmed delivery date agreed to with the Buyer as evidenced in writing, Seller shall be allowed one opportunity to reschedule the delivery and Buyer shall not be entitled to cancel the Order for such reason. In the event Seller does not meet said rescheduled delivery, Buyer may cancel the Order and not be in default under the Agreement, including the terms of this Section 6.

- 7. Indemnity:** Buyer hereby specifically agrees to save Seller harmless and indemnify Seller against all claims for damage or profits and for all costs and attorney fees incurred by Seller resulting from any suit or suits arising from alleged infringements of patents, design copyrights, or trademarks with respect to all goods manufactured, either in whole or in part, to Buyer's specifications.

Seller, at its expense, will defend Buyer and its customer against any reasonable and good faith claim based on an allegation that an unaltered LEMO USA product infringes a patent or copyright of another; provided however, that no such obligation shall apply to (i) any LEMO USA product manufactured to Buyer's specifications and/or designs or (ii) any product that has been modified, altered, misused or damaged by Buyer or a third party. Seller shall pay any reasonable resulting costs, damages and attorney's fees finally awarded against Buyer or its customer that are attributable to such claim or will pay the part of any settlement that is attributable to such claim, provided that: (a) Buyer notifies Seller promptly in writing of the claim; (b) Seller is permitted to control the defense or settlement of the claim; and (c) Buyer and its customer cooperate reasonably in such defense or settlement.

- 8. Returns:** All NON-CANCELABLE/NON-RETURNABLE products shall not be returned. Subject to Section D, Subsection 3 of the Distribution Agreement, If Buyer intends to return standard product, a return authorization number is required prior to return shipment and the product may be subjected to a restocking fee. Seller reserves the right not to issue a return authorization. Product must be returned (with shipping costs prepaid) in original packaging and in original condition as when purchased, undamaged, not reconfigured, not obsolete, fit for use, and shall not have been previously shipped from Seller to Buyer or its customer more than one year prior to the date of return. Seller reserves the right to not accept damaged product for credit, replacement, or substitution. If damaged product is accepted by Seller for credit, and damage is caused by the negligence of the Buyer, the Buyer will pay all costs for refurbishment of damaged product. Discovery of product defect and return of product shall be made in the period of time following delivery as provided in the applicable sections of the Uniform Commercial Code. In the event of a return, Seller shall have the right, in its sole discretion, to replace, substitute, or issue a credit to Buyer.
- 9. Payment:** All invoices are delinquent at 30 days past invoice date and will be subject to 1% per month finance charge. Overdue accounts may be placed on credit hold and shipments held. Buyer agrees to pay all reasonable collection charges, including attorney fees, in the event his account is delinquent more than 30 days.
- 10. Payment Taxes:** In the event any sales tax, manufacturer's tax, or other tax is applicable to any shipment made by the Buyer on Buyer's order, such tax shall be added to the selling price and shall be paid by the Buyer.

11. **Title/Risk of Loss:** All prices are F.O.B. Rohnert Park, California, 1% 10 days/Net 30 days and all Seller obligations hereunder are completed when Seller delivers the items, properly consigned, to a common carrier, Seller's delivery to such carrier shall constitute delivery thereof to the Buyer.
12. **Warranties:** Seller warrants to Buyer that the Goods will conform to the applicable drawings or design standards. The express warranty set forth in this agreement is exclusive and is in lieu of all other express or implied warranties, but not limited to, warranties of merchantability and fitness for a particular purpose.

EXCEPT AS EXPRESSLY SET FORTH IN THIS AGREEMENT, THE SELLER DISCLAIMS ALL EXPRESS AND IMPLIED WARRANTIES, INCLUDING WITHOUT LIMITATION, ANY IMPLIED WARRANTIES, WARRANTIES OF MERCHANTABILITY AND WARRANTIES OF FITNESS FOR A PARTICULAR PURPOSE OR USE.
13. **Disputes and Resolution; Attorney's Fees:** The parties agree that any disputes or questions arising hereunder including the construction or application of the Agreement, including these Terms and Conditions shall be settled in the State of California, according to the laws of the State of California. The parties hereto hereby consent to jurisdiction and venue in the Superior Court of Sonoma County, California, and in the Federal District Court for the Northern District of California, with respect to all disputes or disagreements under the Agreement, including these Terms and Conditions and agree that any action with respect to any of the foregoing shall be brought and maintained only in such courts sitting in the Northern District of California or Sonoma County, as appropriate. In any court action at law or in equity, which is brought by one of the parties to enforce or interpret the provisions of the Agreement, including these Terms and Conditions, the prevailing party will be entitled to costs and reasonable attorney's fees, in addition to any other relief to which that party may be entitled.
14. **Confidentiality:** Both parties acknowledge that during the course of business, each may obtain confidential information regarding the other party's business. Both parties agree to treat all such information as confidential and to take all reasonable precautions against disclosure of such information to unauthorized third parties during and for five (5) years after the term of all orders. Upon request by an owner, all documents relating to the confidential information will be returned to such owner.
15. **Assignment:** It is agreed by the parties that there will be no assignment or transfer of any order or any interest in any orders. Action by a party in violation of this provision will dismiss the other party from any further obligations arising from any orders.
16. **Entire Terms & Conditions:** These Terms & Conditions, together with the Agreement contain the entire agreement of the parties and there are no other promises or conditions in any other agreements whether oral or written. This document, together with the Agreement, supersedes any prior written or oral agreements between the parties.
17. **Amendment:** These Terms & Conditions may be modified or amended if the amendment is made in writing and is signed by both parties; provided however, that the terms of the Agreement shall control in any case where there is a conflict between these Terms & Conditions and the Agreement.
18. **Severability:** If any provision of these Terms & Conditions shall be held to be invalid or unenforceable for any reason, the remaining provisions shall continue to be valid and enforceable. If a court finds that any provision is invalid or unenforceable, but that by limiting such provision it would become valid and enforceable, then such provision shall be deemed to be written, construed and enforced as so limited.
19. **Waiver of Contractual Right:** The failure of either party to enforce any provision of these Terms & Conditions shall not be construed as a waiver or limitation of that party's right to subsequently enforce and compel strict compliance with every provision of this Contract.
20. **Limitation on Damages:** Buyer's consequential or incidental damages for any Seller breach of the contract, except for Seller's gross negligence or willful misconduct, will be limited to the purchase price. Subject to Section 7 hereof, Seller will have no liability to Buyer for any damages, losses, liabilities, injuries, claims, demands or expenses arising out of or directly or indirectly connected with the use of the product. Seller shall not be liable for any exemplary, indirect, incidental, or consequential damages sustained or incurred in connection with the use of the product regardless of the form of action, whether in contract, tort (including negligence) or strict liability.

SELLER SHALL NOT BE LIABLE FOR ANY DAMAGES DUE TO CAUSES BEYOND THE REASONABLE CONTROL OF SELLER OR ATTRIBUTABLE TO ANY SERVICE, PRODUCTS, OR ACTIONS OF ANY PERSON OTHER THAN SELLER REGARDLESS OF THE FORM OF ACTION AND WHETHER OR NOT SUCH DAMAGES ARE FORESEEABLE.

NEITHER PARTY SHALL BE LIABLE IN ANY WAY TO THE OTHER PARTY FOR DELAYS, FAILURE IN PERFORMANCE, OR LOSS OR DAMAGE DUE TO FORCE MAJEURE CONDITIONS SUCH AS: FIRE; LIGHTNING; STRIKE; EMBARGO; EXPLOSION; POWER SURGE OR FAILURE; ACTS OF GOD; WAR; TERRORIST ATTACKS, LABOR DISPUTES; CIVIL DISTURBANCES; ACTS OF CIVIL OR MILITARY AUTHORITY; INABILITY TO SECURE MATERIALS, FUEL, PRODUCTS OR TRANSPORTATION FACILITIES; ACTS OR OMISSIONS OF SUPPLIERS, OR ANY OTHER CAUSES BEYOND ITS REASONABLE CONTROL, WHETHER OR NOT SIMILAR TO THE FOREGOING.

● Product Safety Notice

PLEASE READ AND FOLLOW ALL INSTRUCTIONS CAREFULLY AND CONSULT ALL RELEVANT NATIONAL AND INTERNATIONAL SAFETY REGULATIONS FOR YOUR APPLICATION. IMPROPER HANDLING, CABLE ASSEMBLY, OR USE OF CONNECTORS CAN RESULT IN HAZARDOUS SITUATIONS.

1. SHOCK AND FIRE HAZARD

Incorrect wiring, the use of damaged components, foreign objects (such as metal debris), and / or the presence of residue (such as cleaning fluids), can result in short circuits, overheating, and / or risk of electric shock. Mated components should never be disconnected while live as this may result in an exposed electric arc and local overheating, resulting in possible damage to components.

2. HANDLING

Connectors and their components should be visually inspected for damage prior to installation and assembly. Suspect components should be rejected or returned to the factory for verification. Connector assembly and installation should only be carried out by properly trained personnel. Proper tools must be used during installation and / or assembly in order to obtain safe and reliable performance.

3. USE

Connectors with exposed contacts should never be live (or on the current supply side of a circuit). Under general conditions voltages above 30 VAC and 42 VDC are considered hazardous and proper measures should be taken to eliminate all risk of transmission of such voltages to any exposed metal part of the connector.

4. TEST AND OPERATING VOLTAGES

The maximum admissible operating voltage depends upon the national or international standards in force for the application in question. Air and creepage distances impact the operating voltage; reference values are indicated in the catalog however these may be influenced by PC board design and / or wiring harnesses. The test voltage indicated in the catalog is 75% of the mean breakdown voltage; the test is applied at 500 V/s and the test duration is 1 minute.

5. CE MARKING

CE Marking is applied to a complete product or device, and implies that the device complies with one or several European safety directives. CE Marking can NOT be applied to electromechanical components such as connectors.

6. PRODUCT IMPROVEMENTS

The LEMO Group reserves the right to modify and improve to our products or specifications without providing prior notification.

● Design Engineering Services

DATE: _____

LEMO creates custom designs to fit your unique application, ranging from connector to multi-component assemblies.

- **Custom Connectors** - Precision designs tested to your specifications
- **Cable Assembly** - Electronic and hybrid fiber optic cable assemblies to meet a wide variety of demanding applications
- **Cable Assembly Integration** - Consultation on routing of cable and connections within your product
- **Rapid Prototyping** - Onsite engineering and rapid prototyping capabilities to assist in the high demands of product development
- **Pro/ENGINEER®** 3D solid CAD models available

Manufacturing Services

Outsource your manufacturing challenges. LEMO's capable engineering staff can create solutions for your cable assembly or component sub-assembly designs.

- **Cable Assembly** - Expertise in both electronic and fiber optic connector termination
- **Overmolding Design and Manufacture** - Custom overmold designs to enhance aesthetics while providing durability and strength
- **Sub-Assembly Build** - Combine our connectors and cable assemblies with your sub-assemblies to provide a tested and proven module

I am interested in:

- Design Engineering Services
 Manufacturing Services

Please send me information on:

Name		Rep. Name	
Title		Telephone	Fax
Company Name		Email	
Street			
City	State	Zip	

Please detach and fax directly to LEMO at (707) 578-0869,
or mail to LEMO USA, Attn.: Engineering, P.O. Box 2408, Rohnert Park, CA 94927-2408

● Connector Specification Request Form

DATE: _____

Name		Rep. Name	
Title		Telephone	Fax
Company Name		Email	
Street			
City	State	Zip	

Detailed description of end product, unit or applicaton (please be specific on program information, project name, description, etc.) including applicable standards (if any): Please attach drawing. _____

Connector Description

SHELL CONFIGURATION: _____ SERIES/SIZE: _____

HOUSING MATERIAL: _____ FINISH: _____

FERRULE SIZE (I/D): _____ FIBER SIZE (EG, 50/125, 62.5/125) _____

NUMBER OF FIBERS: _____ FIBER TYPE: _____

SINGLEMODE OR MULTIMODE APPLICATION?: _____ WAVELENGTH: _____

BACK REFLECTION REQUIREMENTS (dB): _____ INSERTION LOSS (dB): _____

NUMBER OF ELECTRICAL CONTACTS: _____ VOLTAGE: _____ CURRENT: _____

TYPE OF TERMINATION PREFERRED: SOLDER CRIMP PRINTED CIRCUIT OTHER _____

CONDUCTOR DIAMETER OF THE CABLE (AWG) _____ IF COAX, CABLE TYPE _____

JACKET O.D. OF THE CABLE AND TYPE OF MATERIAL: _____

Environment

OPERATING TEMPERATURES: _____

ENVIRONMENT: CLEAN WASH DOWN OR SPLASH SALT WATER SPRAY UNDERWATER

DIRT FLUIDS _____ DUST GASES _____

CHEMICALS IP RATING _____ EXPLOSIVES RADIATION

STERILIZATION: YES NO METHOD _____ CYCLES _____ TEMP _____

Purchase Projections

PROTOTYPE ORDER QUANTITY (3 OR LESS): _____ EXPECTED DELIVERY DATE: _____

PRODUCTION ORDER QUANTITY: _____ EXPECTED DELIVERY DATE: _____

PREPRODUCTION ORDER QUANTITY: _____ EXPECTED DELIVERY DATE: _____

EXPECTED QUANTITY INVOLVED EACH YEAR: _____ TARGET PRICING PER PAIR: \$ _____

APPLICABLE STANDARDS: UL IEC OTHER _____

PLEASE ATTACH DRAWING IF POSSIBLE OR NECESSARY



Located 50 miles north of San Francisco, LEMO USA offers a nationwide network of product specialists, sales consultants and distributors, who work closely with customers in offering sales and technical support.



635 Park Court, Rohnert Park, CA 94928
P.O. Box 2408, Rohnert Park, CA 94927-2408
(800) 444-5366 • (707) 578-8811 • fax: (707) 578-0869
www.lemousa.com • e-mail: info@lemousa.com

Mouser Electronics

Authorized Distributor

Click to View Pricing, Inventory, Delivery & Lifecycle Information:

[LEMO:](#)

[EGG.5K.90C.CLY](#) [FFS.2B.250.ZTCE30](#)