

THIS DOCUMENT IS THE PROPERTY OF KEYSTONE ELECTRONICS CORP. AND SHALL NOT BE REPRODUCED, DISTRIBUTED OR USED AS A BASIS FOR MANUFACTURE WITHOUT PRIOR WRITTEN PERMISSION FROM KEYSTONE ELECTRONICS CORP.

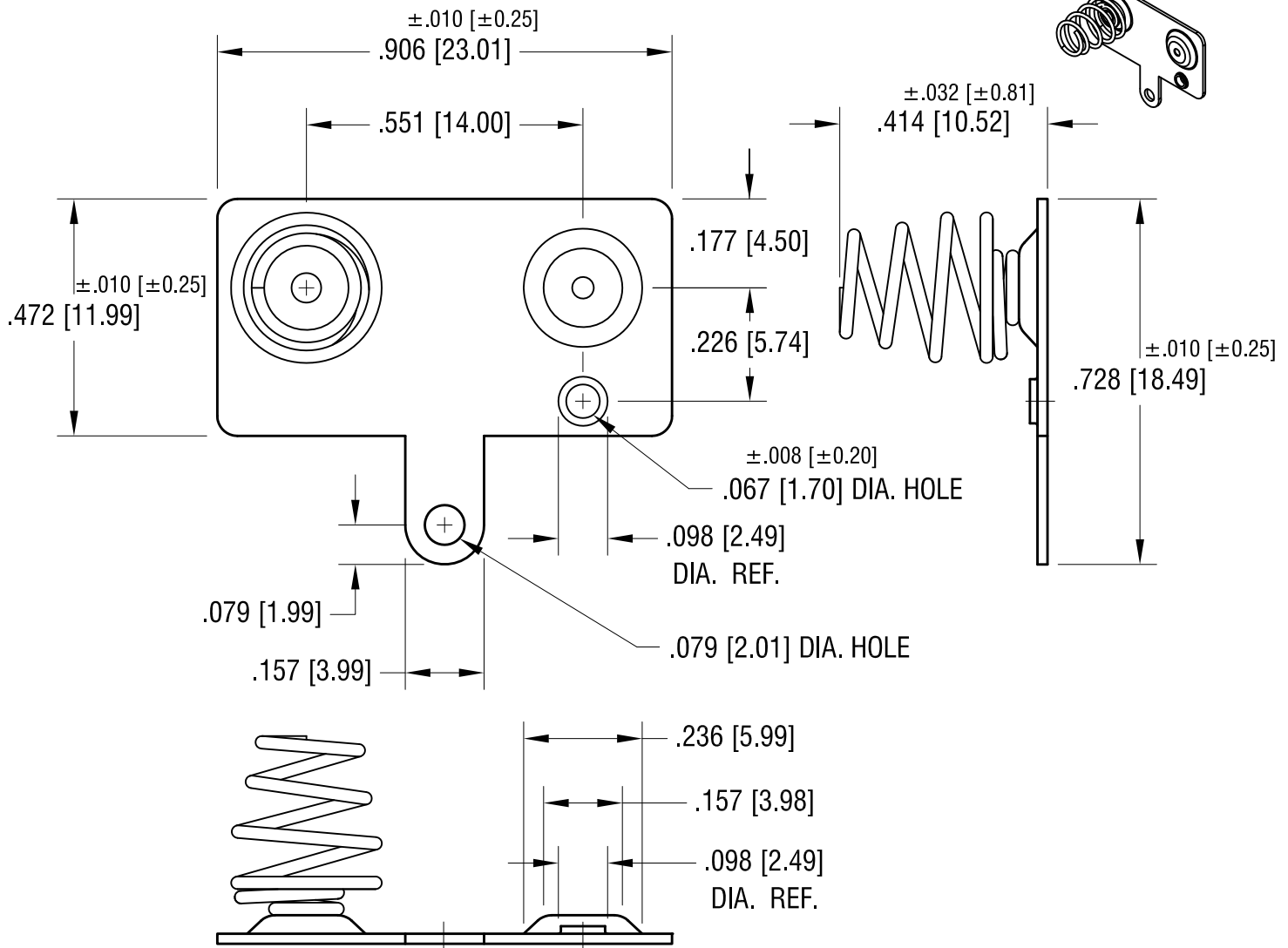

NOTES:

1. BASE:

MAT'L - .020 [0.50] THK STEEL

SPRING CONTACT:

MAT'L - .023 [0.58] DIA. MUSIC WIRE

DATE	DESCRIPTION	REV.
10.16.15	CHANGE AS PER ECN 15-122	B
7.8.05	CHANGE AS PER ECN 05-046	A

<b>KEYSTONE ELECTRONICS CORP.</b>			
www.keyelco.com • ASTORIA, N.Y. 11105-2017 • Tel (718) 956-8900			
PART NAME			
'AA' DUAL M/F BATTERY CONTACT			
MATERIAL			
AS NOTED			
FINISH		DRN BY	DATE
NICKEL PLATE		BOONE	2.26.96
		APP'D	SCALE
		LN	3X
TOLERANCES	INCH [MM]	CODE	DWG NO.
DECIMAL	$\pm .005$ [ $\pm 0.13$ ]	C	
ANGULAR	$\pm 1^\circ$		
UNLESS OTHERWISE SPECIFIED			
			<b>5211</b>