

# SPECIFICATION

Sep-4-2009

OF

## LIQUID CRYSTAL DISPLAY MODULE

CUSTOMER : \_\_\_\_\_

Model No. : UMSH-3267MD-1UB

Model version : 0

Document Revision : 1

TENTATIVE

CUSTOMER APPROVED SIGNATURE			

This specification need to be signed by purchaser or customer as a specification of products production and delivery from Microtips. Without signature of this specification , any purchase order for this model no. will be treated and considered that this specification is automatically acknowledged and accepted by purchaser or customer.



**MICROTIPS USA TECHNOLOGY**

Allen Wang  
APPROVED

George Tseng  
CHECKED

Angus Chiu  
CHECKED

Sharon Tsai  
PREPARED

Sep-4-2009  
Date

COMPANY : 3504 Lake Lynda Drive, Ste. 110, Orlando, FL 32817. USA

TEL: 407-273-0204



Revision 1 ; UMSH-3267MD-1UB Ver. 0 ; September-04-2009

Page: 1

*This document has been signed by Digital Signature Approval System*



## CONTENTS:

No.	Item	Page
1	<b>BASIC SPECIFICATION</b>	
	1.1 Mechanical Specification	4
	<b>1.2 Display Specification</b>	4
	1.3 Outline Dimension	5
	1.4 Block Diagram	6
	1.5 Interface Pin	7
2	<b>ELECTRICAL CHARACTERISTICS</b>	
	2.1 Absolute Maximum Ratings	8
	2.2 Command Sequence	9
	2.3 Standard Character Pattern	10
	2.4 DC Characteristics	11
	2.5 Back-light Characteristics	12
	2.6 AC Characteristics	13~14
3	<b>OPTICAL CHARACTERISTICS</b>	
	3.1 Condition	15
	3.2 Definition of Optical Characteristics	16
4	<b>RELIABILITY</b>	17
5	<b>PRODUCT HANDING AND APPLICATION</b>	18
6	<b>DATECODE</b>	19
7	<b>PACKING &amp; LOTNO</b>	20~21
8	<b>INSPECTION STANDARD</b>	22~25



## 1. BASIC SPECIFICATION

### 1.1 Mechanical specifications

Items	Nominal Dimension	Unit
Character Line	20×2 Chars	Pixel
Module Size (W x H x T)	37.0 x 116.0 x 17.2	mm.
Viewing Area (W×H)	73.8 x 16.5	mm.
Active Area (W x H)	70.8 x 11.5	mm.
Character Font ( W × H )	5×8 dots	mm.
Character Size ( W × H )	3.065 × 5.56	mm.
Character Pitch ( W × H )	3.565 × 5.94	mm.
Dot Size (W×H)	0.585 x 0.66	mm.
Dot Pitch (W x H)	0.62 x 0.7	mm.
Driving Method	1/ 8	Duty
	1/ 4	Bias
Driving IC Package	COB	-
Module Weight	TBD	g

### 1.2 Display specification

Display	Descriptions	Note
LCD Type	2.95" UB	-
LCD Mode	Negative	-
Polarizer Mode	Transmissive	-
Polarizer UV - Cutting	Without	
Polarizer Surface	Normal	-
Backlight Type	LED	-
Backlight Color	Red	
Viewing Direction	6 O'clock Direction	-

Color tone is slightly changed by temperature and driving voltage.





**1.4 Block diagram:**

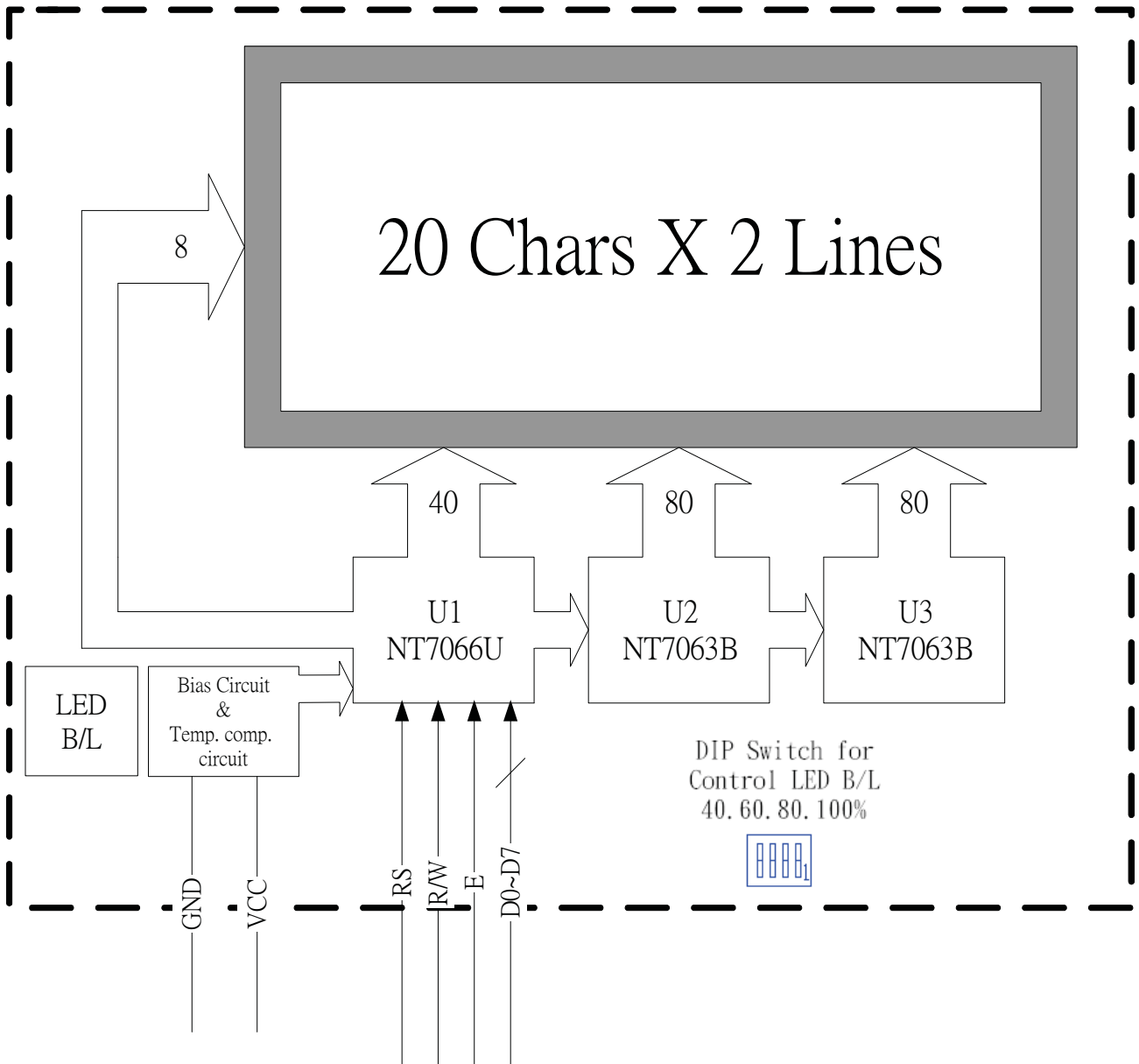

## 1.5 Interface pin :

Pin No.	Pin Name	I/O	Description
1	GND	P	Ground.(0V)
2	VCC	P	Power supply.(+5V)
3	NC	-	Not connection.
4	RS	I	Register select signal: 0: Instruction register. 1: Data register.
5	R/W	I	Read/Write control signal: 0:Write 1: Read
6	E	I	Read/Write enable signal.
7~14	D0~D7	I	Data bus(8-bits).
15-16	NC	-	Not connection.

Dip switch for B/L Brightness Control PIN:

1	40 % Brightness of the Backlight.
2	60 % Brightness of the Backlight.
3	80 % Brightness of the Backlight.
4	100 % Brightness of the Backlight.



## 2. ELECTRICAL CHARACTERISTICS

### 2.1 Absolute Maximum Ratings

<b>Items</b>	<b>Symbol</b>	<b>Min.</b>	<b>Max.</b>	<b>Unit</b>
Supply voltage	<b>VDD</b>	<b>-0.3</b>	<b>+7.0</b>	V
Supply voltage for driving LCD	<b>VLCD-V5</b>	<b>VDD-15</b>	<b>VDD+0.3</b>	V
Input voltage	<b>VIN</b>	<b>-0.3</b>	<b>VDD+0.3</b>	V
Operate temperature range	<b>T<sub>OP</sub></b>	<b>-30</b>	<b>80</b>	°C
Storage temperature range	<b>T<sub>ST</sub></b>	<b>-40</b>	<b>80</b>	°C





## 2.2 Command Sequence

### INITIALIZING BY INSTRUCTION

8-bit interface mode

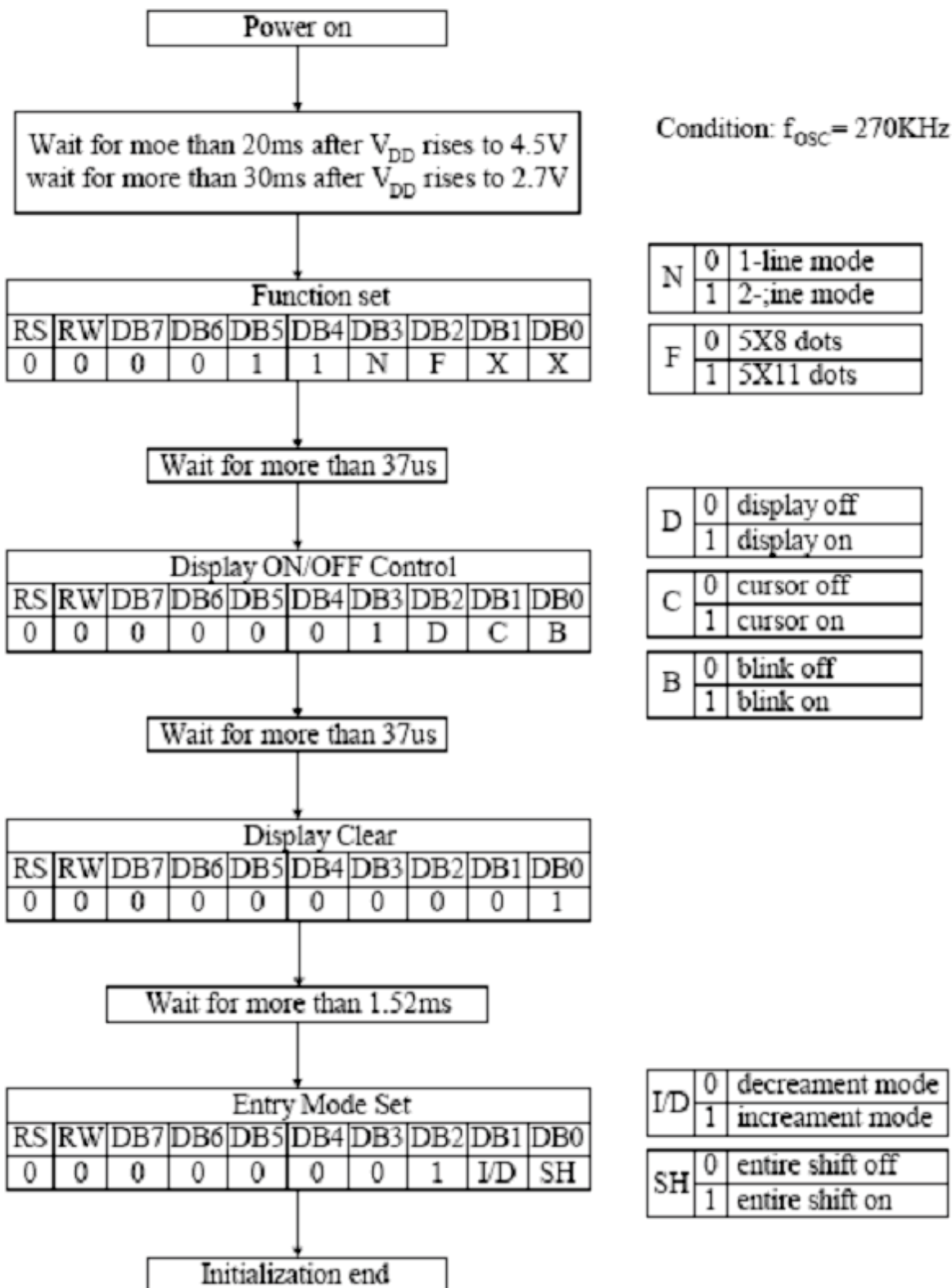

## 2.3 Standard Character Pattern

Higher 4-bit of character code (Hex.)

	0	1	2	3	4	5	6	7	8	9	A	B	C	D	E	F
0 CG RAM (1)			0	@	P	^	P				-	夕	三	α	p	
1 (2)		!	1	A	Q	a	9			。	ア	チ	厶	ä	q	
2 (3)		"	2	B	R	b	r			「	イ	ツ	×	β	θ	
3 (4)		#	3	C	S	c	s			」	ウ	テ	ε	ε	∞	
4 (5)		\$	4	D	T	d	t			、	エ	ト	ト	μ	Ω	
5 (6)		%	5	E	U	e	u			・	オ	ナ	ユ	σ	ü	
6 (7)		&	6	F	V	f	v			ヲ	カ	ニ	ヨ	ρ	Σ	
7 (8)		'	7	G	W	g	w			ア	キ	ヌ	ラ	g	π	
8 (1)		(	8	H	X	h	x			ィ	ク	ネ	リ	γ	×	
9 (2)		)	9	I	Y	i	y			ウ	ケ	ル	ル	”	γ	
A (3)		*	:	J	Z	j	z			エ	コ	ハ	レ	j	〒	
B (4)		+	;	K	[	k	[			オ	サ	ヒ	ロ	×	π	
C (5)		,	<	L	¥	l	l			カ	シ	フ	フ	φ	π	
D (6)		-	=	M	]	m	]			ユ	ヌ	ハ	ン	も	÷	
E (7)		.	>	N	^	n	→			ヨ	セ	ホ	°	π		
F (8)		/	?	O	_	o	+			ッ	リ	マ	°	ö	■	

Lower 4-bit of character code (Hex.)



## 2.4 DC Characteristics

Items	Symbol	Min.	Typ.	Max.	Unit	Condition
Supply voltage (Logic)	VDD	TBD	5.0	TBD	V	
Supply Voltage (LCD)	VLCD	6.55	6.85	7.15	V	Top = 80°C
		6.55	6.85	7.15	V	*NOTE1
		6.75	7.05	7.35	V	Top = -30°C
Input logic HIGH	V <sub>IH</sub>	VDD-1.0	-	VDD	V	
Input logic LOW	V <sub>IL</sub>	-0.2	-	1.0	V	
Power supply current	I <sub>DD</sub>	-	TBD	TBD	mA	*NOTE2
Backlight Voltage	V <sub>ee</sub>	2.8	3.2	3.6	V	
Backlight current	I <sub>ee</sub>	--	200	--	mA	*NOTE3

\*NOTE1: If change the VDD, the voltage boost and contrast need to be set again.

\*NOTE2: Min. and Max. Voltage is mean within the range will has optimum contrast at Ta:25°C

Typ. Voltage is specified as module driving condition: Ta=25°C, V<sub>OP</sub> at Optimum Contrast, the measuring condition as below, this value is URT recommend when customer change the set condition, the V<sub>LCD</sub> will be change.

\*NOTE4: The Back light is constant current.

\*NOTE3 :

Measuring Condition :

Standard Value MAX.

Ta = 25°C

VDD-VSS = 5.0V

VEE-VSS = About 3.2V (200mA)

Fosc = 270 KHz

Bias = 1/4 Bias

Duty = 1/8 Duty

Display Patten = Checkered pattern



## 2.5 Back-light Characteristics

PARAMETER	SYMBOL	MIN	TYP	MAX	Unit	Test Condition	NOTE
Supply Current	If	--	200	--	mA	Ta=25°C	1
Supply Voltage	Vs	2.8	3.2	3.6	V	Ta=25°C	-

Note 1 : The Back light is constant current.



## 2.6 AC Characteristics

( $V_{DD} = 4.5V \sim 5.5V$ ,  $T_a = -30 \sim +85^{\circ}C$  )

Mode	Characteristic	Symbol	Min.	Typ.	Max.	Unit
Write mode (refer to Fig.6)	E cycle time	$t_C$	500	-	-	ns
	E rise/fall time	$t_R, t_F$	-	-	20	
	E pulse width (high, low)	$t_W$	230	-	-	
	R/W and RS setup time	$t_{SU1}$	40	-	-	
	R/W and RS hold time	$t_{H1}$	10	-	-	
	Data setup time	$t_{SU2}$	60	-	-	
	Data hold time	$t_{H2}$	10	-	-	
Read mode (refer to Fig.7)	E cycle time	$t_C$	500	-	-	ns
	E rise/fall time	$t_R, t_F$	-	-	20	
	E pulse width (high, low)	$t_W$	230	-	-	
	R/W and RS setup time	$t_{SU}$	40	-	-	
	R/W and RS hold time	$t_H$	10	-	-	
	Data output delay time	$t_D$	-	-	120	
	Data hold time	$t_{DH}$	5	-	-	



## 2.6 AC Characteristics (Cont.)

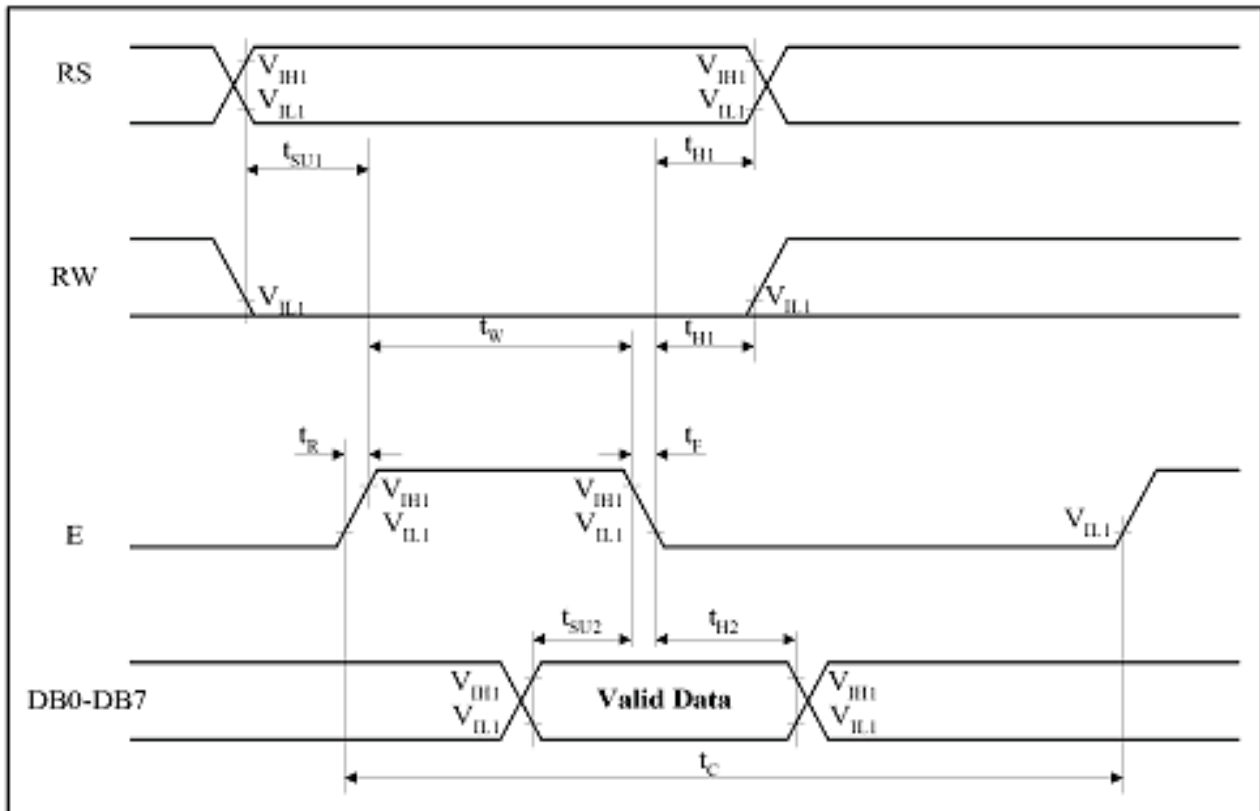

**Write mode timing diagram**

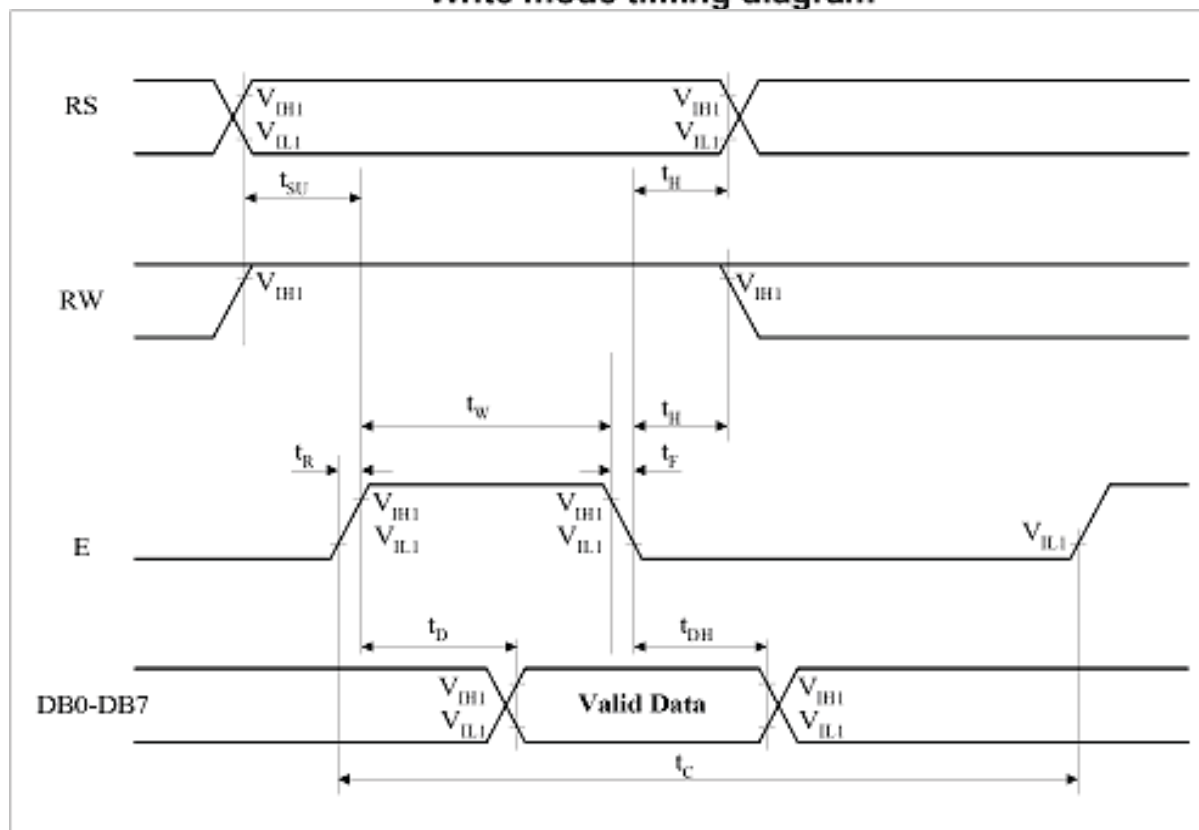

**Read mode timing diagram**



### 3. OPTICAL CHARACTERISTICS

#### 3.1 Characteristics

Electrical and Optical Characteristics

No.	Item			symbol / temp	Min.	Typ.	Max.	Unit	Note	
1	Response Time			Tr	25 °C	-	80	ms	2	
				Tf	25 °C	-	35			70
2	Viewing Angle	Hor.	Cr>=2	Θ <sub>2+</sub>	0°	60	75	-	degree	3
				Θ <sub>2-</sub>	180°	60	75	-		
		Ver.		Θ <sub>1+</sub>	270°	60	75	-		
				Θ <sub>1-</sub>	90°	40	50	-		
3	Contrast Ratio			Cr	25 °C	400	800	-	-	4
4	Brightness			Y		240	400	-	cd/m <sup>2</sup>	



### 3.2 Definition of optical characteristics

Measurement condition :

Transmissive and Transflective type

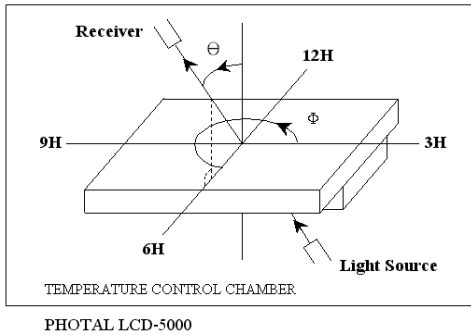

[Note 1] Definition of LCD Driving Vop and Waveform :

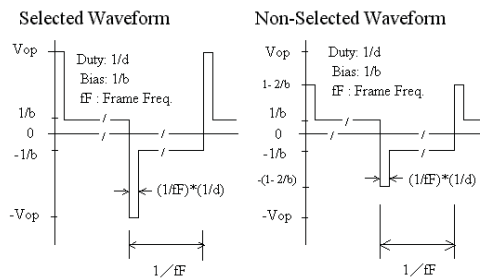
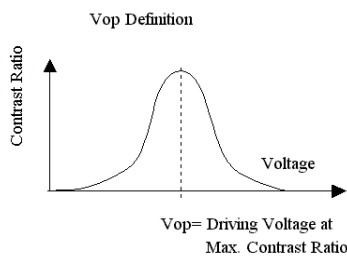

[Note 2] Definition of Response Time

for Negative type :

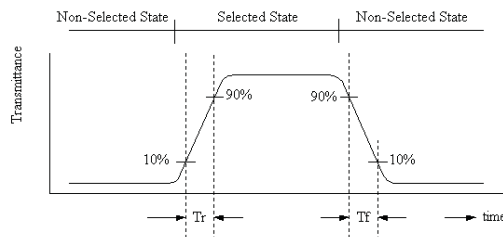

[Note 3] Definition of Viewing Angle :

[Note 4] Definition of Contrast Ratio :

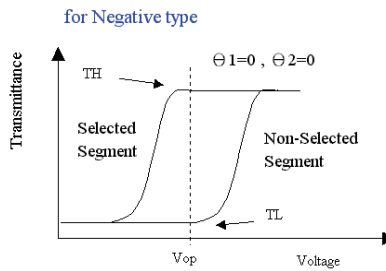
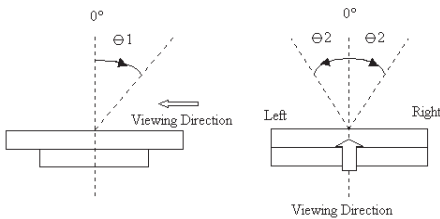



#### 4. RELIABILITY :

Item No	Items	Condition
1	High temperature operating	80 °C , 200 hours
2	Low temperature operating	-30 °C , 200 hours
3	High temperature storage	80 °C , 200 hours
4	Low temperature storage	-40 °C , 200 hours
5	High temperature & humidity storage	<b>60°C, 90%RH, 100 hours</b>
6	Thermal Shock storage	-40°C, 30min.<=> 80°C, 30min. 10 Cycles
7	Vibration test	10 => 55 =>10 => 55 => 10 Hz , within 1 minute Amplitude : 1.5mm. 15 minutes for each Direction ( X,Y,Z )
8	Drop test	Packed, 100CM free fall, 6 sides, 1 corner, 3edges
9	Life time	50,000 hours 25°C , 70%RH below , <b>specification condition driving</b>

\* One single product test for only one item.

\* Judgment after test : keep in room temperature for more than 2 hours.

- Current consumption < 2 times of initial value
- Contrast > 1/2 initial value
- Function : work normally



## 5. PRODUCT HANDLING AND APPLICATION

### PRECAUTION FOR HANDLING LCM

- The LCD module contains a C-MOS LSI. People who operate the LCM should wear ESD protection equipment to prevent ESD hurt on products.
- Do not input any signal before power is turned on.
- Do not take LCM from its packaging bag until it is assembled.
- Peel off the LCM protective film slowly since static electricity may be generated.
- Pay attention to the humidity of the work shop, 50~60%RH is satisfactory.
- Use a non-leak iron for soldering LCM.
- Do not touch the display surface or connection terminals area with bare hands. Smudges on the display surface reduce the insulation between terminals.
- Cautions for soldering to LCM:  
Condition for soldering I/O terminals:  
Temperature at iron tip :350°C±15°C.  
Soldering time : 3~4sec./ terminals.  
Type of solder : Eutectic solder(rosin flux filled).

### PRECAUTION IN USE OF LCD

- Do not contact or scratch the front surface and the contact pads of a LCD panel with hard materials such as metal or glass or with one's nail.
- To clean the surface , wipe it gently with soft cloth dampened by alcohol.
- Do not attempt to wipe off the contact pads.
- Keep LCD panels away from direct sunlight , also avoid them in high-temperature & high humidity environment for a long period.
- Do not drive LCD panels by DC voltage.
- Do not expose LCD panels to organic solvent.
- Liquid in LCD is hazardous substance. In case a contact with liquid crystal material is occurred, be sure to immediately wash such material away by soap and water.
- The polarizer is easily damaged and should be handle with special care. Don't press or rub it with hard objects.

### PRECAUTION FOR STORING LCM

- To avoid degradation of the device , do not store the module under the conditions of direct sunlight , high temperature or high humidity . Keep the module in bags designed to prevent static electricity charging under low temperature / normal humidity conditions(avoid high temperature / high humidity and low temperature below 0°C)

### USING ON MEDICAL CARE , SAFETY OR HAZARDOUS APPLICATION OR SYSTEM

- For the application in medical care, safety and hazardous products or systems, an authorization from us is required. We will not responsible for any damage or loss which caused by the products without any authorization given by us.
- This product is not allowed to be designed and used for military application and/or purpose.
- The delivery of this product to the countries and/or regions where the embargoes are imposed by U.N. is prohibited.
- The application and delivery of this product must comply with Startegic High-Tech Commodities (SHTC) export control and the sales to the embargoed and/or sanctioned countries or regions are strictly prohibited.



## 6. DATE CODE OF PRODUCTS

- Date code will be shown on each product :

- YY MM DD - XXXX

|        |        |        |  
Year Month Day - Production lots

- Example: 090508 - 0 0 0 3 ==>Year 2009, May.,08rd , Batch no.03



## 7. PACKING

Instruction of lot number:

LOT NO. : 0 0 0 8 3 5 2 5 (EX)

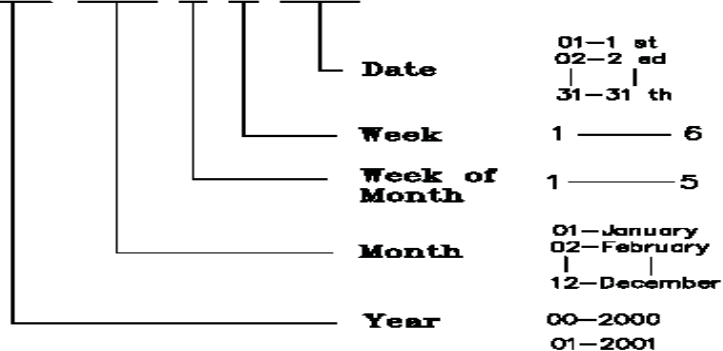

Label of carton:

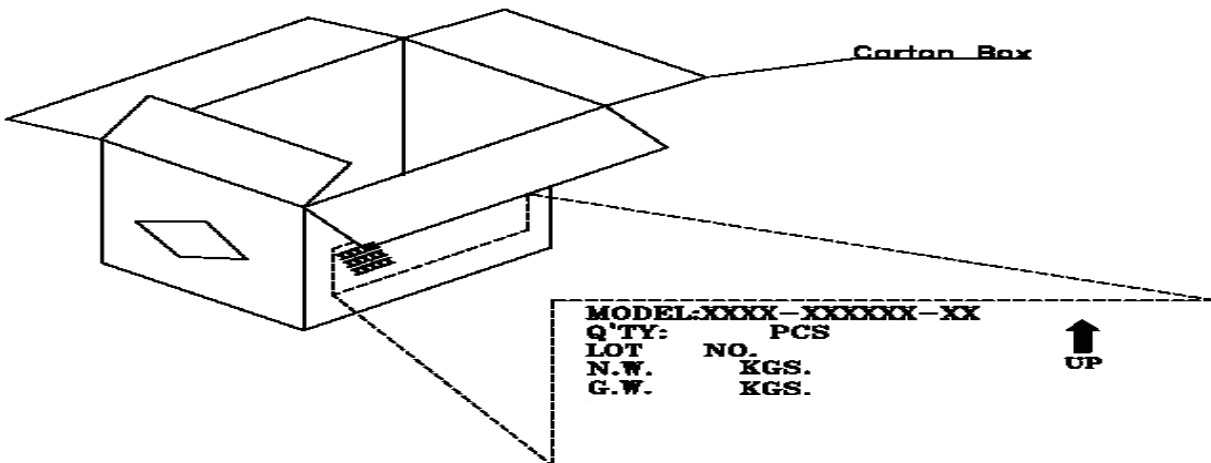

Packing tray must be stacked with alternated direction to each others.  
 To tacks packing trays in same direction will cause product damaged.

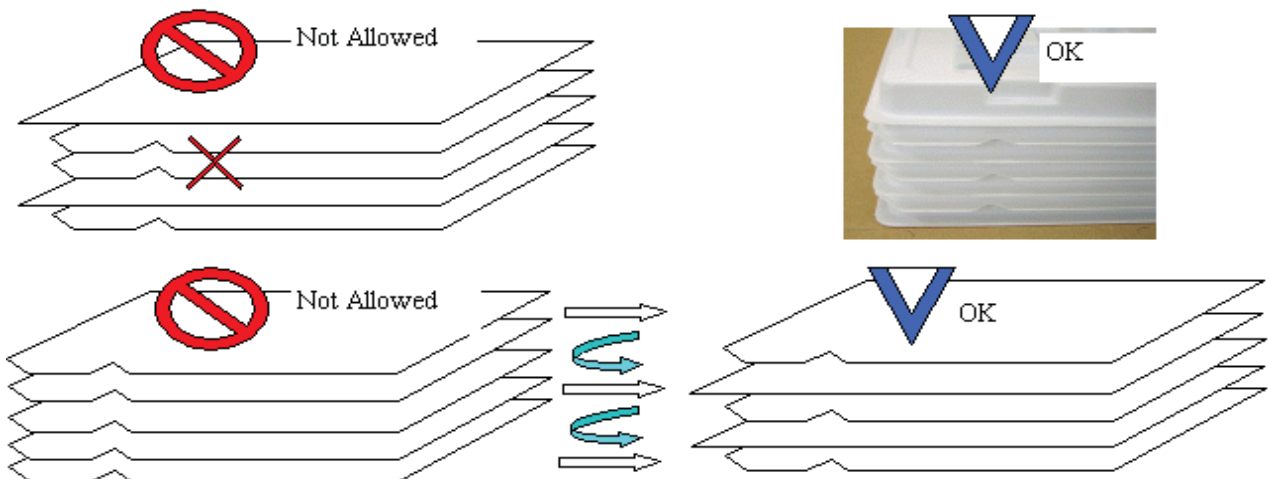

MODEL NO: UM\*

T.B.D. pcs / Tray

T.B.D. Tray / Box

T.B.D. Box / Carton

T.B.D. pcs / Carton

NOTE:

- (1) Be warned, the direction of the tray has to turn it by 180 degree before stack it up. Otherwise, it will be packager's responsibility!!
- (2) Safe Stack : 5 cartons only

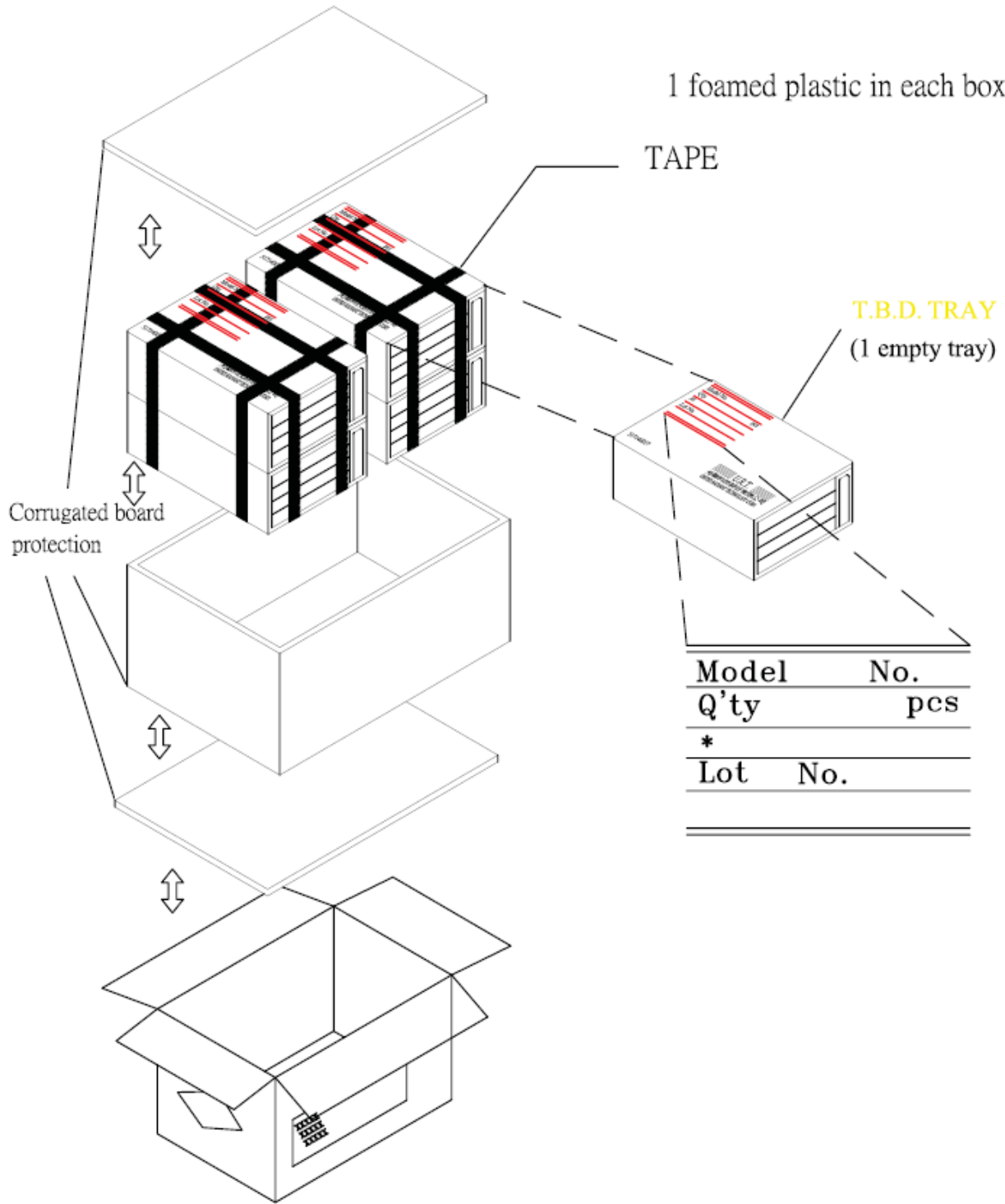

## 8. INSPECTION STANDARD

### 8.1. QUALITY :

THE QUALITY OF GOODS SUPPLIED TO PURCHASER SHALL COME UP TO THE FOLLOWING STANDARD.

#### 8.1.1. THE METHOD OF PRESERVING GOODS

AFTER DELIVERY OF GOODS FROM MICROTIPS TO PURCHASER. PURCHASER SHALL CONTROL THE LCM AT  $-10^{\circ}\text{C} \sim 40^{\circ}\text{C}$  ,AND IT MIGHT BE DESIRABLE TO KEEP AT THE NORMAL ROOM TEMPERATURE AND HUMIDITY UNTIL INCOMING INSPECTION OR THROWING INTO PROCESS LINE.

#### 8.1.2. INCOMING INSPECTION

##### (A) THE METHOD OF INSPECTION

IF PURCHASER MAKE AN INCOMING INSPECTION , A SAMPLING PLAN SHALL BE APPLIED ON THE CONDITION THAT QUALITY OF ONE DELIVERY SHALL BE REGARDED AS ONE LOT.

##### (B) THE STANDARD OF QUALITY

ISO-2859-1 ( or MIL-STD-105E ) , LEVEL II SINGLE PLAN.

CLASS	AQL(%)
CRITICAL	0.4 %
MAJOR	0.65 %
MINOR	1.5 %
TOTAL	1.5 %

EVERY ITEM SHALL BE INSPECTED ACCORDING TO THE CLASS.

##### (C) MEASURE

IF AS THE RESULT OF ABOVE RECEIVING INSPECTION , A LOT OUT IS DISCOVERED. PURCHASER SHALL BE INFORM SELLER OF IT WITHIN SEVEN DAYS. BUT FIRST SHIPMENT WITHIN FOURTEEN DAYS.

#### 8.1.3. WARRANTY POLICY

WE WILL PROVIDE ONE-YEAR WARRANTY FOR THE PRODUCTS ONLY IF UNDER SPECIFICATION OPERATING CONDITIONS. WE WILL REPLACE NEW PRODUCTS FOR THESE DEFECT PRODUCTS WHICH UNDER WARRANTY PERIOD AND BELONG TO THE RESPONSIBILITY OF US.

## 8.2. CHECKING CONDITION

8.2.1. CHECKING DIRECTION SHALL BE IN THE 45 DEGREE AREA TO FACE THE SAMPLE.

8.2.2. CHECKER SHALL SEE OVER 30 cm. WITH BARE EYES FAR FROM SAMPLE AND USING 2 PCS. OF 20W FLUORESCENT LAMP.



### 8.3. INSPECTION PLAN :

CLASS	ITEM	JUDGEMENT	CLASS
PACKING & INDICATE	1. OUTSIDE AND INSIDE PACKAGE	"MODEL NO." , "LOT NO." AND "QUANTITY" SHOULD INDICATE ON THE PACKAGE.	Minor
	2. MODEL MIXED AND QUANTITY	OTHER MODEL MIXED.....REJECTED QUANTITY SHORT OR OVER.....REJECTED	Critical
	3. PRODUCT INDICATION	"MODEL NO." SHOULD INDICATE ON THE PRODUCT	Major
ASSEMBLY	4. DIMENSION, LCD GLASS SCRATCH AND SCRIBE DEFECT.	ACCORDING TO SPECIFICATION OR DRAWING.	Major
APPEARANCE	5. VIEWING AREA	POLARIZER EDGE OR LCD'S SEALING LINE IS VISABLE IN THE VIEWING AREA .....REJECTED	Minor
	6. BLEMISH 、 BLACK SPOT 、 WHITE SPOT IN THE LCD AND LCD GLASS CRACKS	ACCORDING TO STANDARD OF VISUAL INSPECTION ( INSIDE VIEWING AREA )	Minor
	7. BLEMISH 、 BLACK SPOT WHITE SPOT AND SCRATCH ON THE POLARIZER	ACCORDING TO STANDARD OF VISUAL INSPECTION ( INSIDE VIEWING AREA )	Minor
	8. BUBBLE IN POLARIZER	ACCORDING TO STANDARD OF VISUAL INSPECTION ( INSIDE VIEWING AREA )	Minor
	9. LCD'S RAINBOW COLOR	STRONG DEVIATION COLOR ( OR NEWTON RING) OF LCD.....REJECTED. OR ACCORDING TO LIMITED SAMPLE ( IF NEEDED, AND INSIDE VIEWING AREA )	Minor
ELECTRICAL	10. ELECTRICAL AND OPTICAL CHARACTERISTICS ( CONTRAST 、 VOP 、 CHROMATICITY ... ETC )	ACCORDING TO SPECIFICATION OR DRAWING . ( INSIDE VIEWING AREA )	Critical
	11.MISSING LINE	MISSING DOT 、 LINE 、 CHARACTER .....REJECTED	Critical
	12.SHORT CIRCUIT 、 WRONG PATTERN DISPLAY	NON DISPLAY 、 WRONG PATTERN DISPLAY 、 CURRENT CONSUMPTION OUT OF SPECIFICATION..... REJECTED	Critical
	13. PIN HOLE 、 PATTERN DEFORMITY	ACCORDING TO STANDARD OF VISUAL INSPECTION	Minor

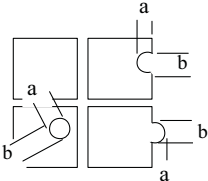

### 8.4. STANDARD OF VISUAL INSPECTION

NO.	CLASS	ITEM	JUDGEMENT																									
8.4.1	MINOR	<ul style="list-style-type: none"> <li>· BLEMISH、BLACK SPOT、WHITE SPOT IN THE LCD.</li> <li>· BLEMISH、BLACK SPOT、WHITE SPOT AND SCRATCH ON THE POLARIZER</li> </ul>	<p>(A) ROUND TYPE: <span style="float: right;">unit : mm.</span></p> <table border="1"> <thead> <tr> <th>DIAMETER (mm.)</th> <th>ACCEPTABLE Q'TY</th> </tr> </thead> <tbody> <tr> <td><math>\Phi \leq 0.1</math></td> <td>DISREGARD</td> </tr> <tr> <td><math>0.1 &lt; \Phi \leq 0.2</math></td> <td>2</td> </tr> <tr> <td><math>0.2 &lt; \Phi \leq 0.25</math></td> <td>1</td> </tr> <tr> <td><math>0.25 &lt; \Phi</math></td> <td>0</td> </tr> </tbody> </table> <p>NOTE: <math>\Phi = (\text{LENGTH} + \text{WIDTH}) / 2</math></p> <p>(B) LINER TYPE: <span style="float: right;">unit : mm.</span></p> <table border="1"> <thead> <tr> <th>LENGTH</th> <th>WIDTH</th> <th>ACCEPTABLE Q'TY</th> </tr> </thead> <tbody> <tr> <td>-----</td> <td><math>W \leq 0.03</math></td> <td>DISREGARD</td> </tr> <tr> <td><math>L \leq 5.0</math></td> <td><math>0.03 &lt; W \leq 0.05</math></td> <td>3</td> </tr> <tr> <td><math>L \leq 5.0</math></td> <td><math>0.05 &lt; W \leq 0.07</math></td> <td>1</td> </tr> <tr> <td>-----</td> <td><math>0.07 &lt; W</math></td> <td>FOLLOW ROUND TYPE</td> </tr> </tbody> </table>	DIAMETER (mm.)	ACCEPTABLE Q'TY	$\Phi \leq 0.1$	DISREGARD	$0.1 < \Phi \leq 0.2$	2	$0.2 < \Phi \leq 0.25$	1	$0.25 < \Phi$	0	LENGTH	WIDTH	ACCEPTABLE Q'TY	-----	$W \leq 0.03$	DISREGARD	$L \leq 5.0$	$0.03 < W \leq 0.05$	3	$L \leq 5.0$	$0.05 < W \leq 0.07$	1	-----	$0.07 < W$	FOLLOW ROUND TYPE
DIAMETER (mm.)	ACCEPTABLE Q'TY																											
$\Phi \leq 0.1$	DISREGARD																											
$0.1 < \Phi \leq 0.2$	2																											
$0.2 < \Phi \leq 0.25$	1																											
$0.25 < \Phi$	0																											
LENGTH	WIDTH	ACCEPTABLE Q'TY																										
-----	$W \leq 0.03$	DISREGARD																										
$L \leq 5.0$	$0.03 < W \leq 0.05$	3																										
$L \leq 5.0$	$0.05 < W \leq 0.07$	1																										
-----	$0.07 < W$	FOLLOW ROUND TYPE																										
8.4.2	MINOR	BUBBLE IN POLARIZER	<p style="text-align: right;">unit : mm.</p> <table border="1"> <thead> <tr> <th>DIAMETER</th> <th>ACCEPTABLE Q'TY</th> </tr> </thead> <tbody> <tr> <td><math>\Phi \leq 0.15</math></td> <td>DISREGARD</td> </tr> <tr> <td><math>0.15 &lt; \Phi \leq 0.5</math></td> <td>2</td> </tr> <tr> <td><math>0.5 &lt; \Phi</math></td> <td>0</td> </tr> </tbody> </table>	DIAMETER	ACCEPTABLE Q'TY	$\Phi \leq 0.15$	DISREGARD	$0.15 < \Phi \leq 0.5$	2	$0.5 < \Phi$	0																	
DIAMETER	ACCEPTABLE Q'TY																											
$\Phi \leq 0.15$	DISREGARD																											
$0.15 < \Phi \leq 0.5$	2																											
$0.5 < \Phi$	0																											
8.4.3	MINOR	PIN HOLE、PATTERN DEFORMITY	<p style="text-align: right;">unit : mm.</p> <div style="display: flex; align-items: center;">  <table border="1" style="margin-left: 20px;"> <thead> <tr> <th>DIAMETER</th> <th>ACC. Q'TY</th> </tr> </thead> <tbody> <tr> <td><math>\Phi \leq 0.1</math></td> <td>DISREGARD</td> </tr> <tr> <td><math>0.1 &lt; \Phi \leq 0.25</math></td> <td>3</td> </tr> <tr> <td><math>0.25 &lt; \Phi</math></td> <td>0</td> </tr> </tbody> </table> </div> <p><math>\Phi = (a+b)/2</math></p>	DIAMETER	ACC. Q'TY	$\Phi \leq 0.1$	DISREGARD	$0.1 < \Phi \leq 0.25$	3	$0.25 < \Phi$	0																	
DIAMETER	ACC. Q'TY																											
$\Phi \leq 0.1$	DISREGARD																											
$0.1 < \Phi \leq 0.25$	3																											
$0.25 < \Phi$	0																											



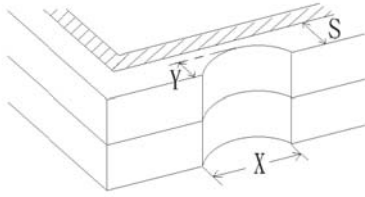
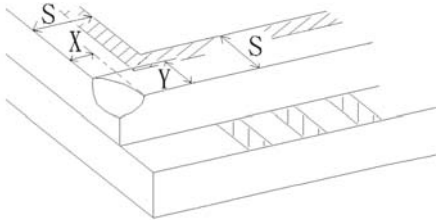
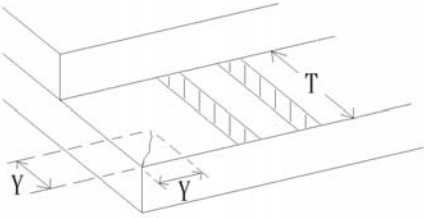
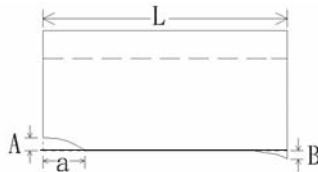
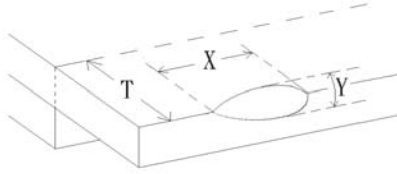
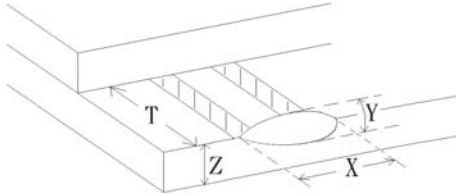
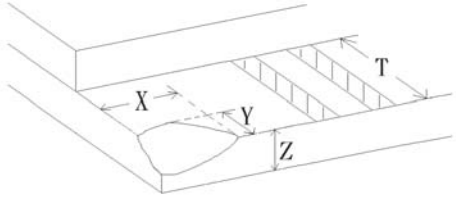

NO.	CLASS	ITEM	JUDGEMENT
8.4.4	MINOR	CHIPPING	 $Y > S$ REJ.
8.4.5	MINOR	CHIPPING	 $X \text{ or } Y > S$ REJ.
8.4.6	MAJOR	GLASS CRACK	 $Y > (1/2) T$ REJ.
8.4.7	MAJOR	SCRIBE DEFECT	 <ol style="list-style-type: none"> <li><math>a &gt; L/3</math>, <math>A &gt; 1.5\text{mm}</math>. REJ.</li> <li>B : ACCORDING TO DIMENSION</li> </ol>
8.4.8	MINOR	CHIPPING (ON THE TERMINAL AREA)	 $\Phi = (x+y)/2 > 2.5 \text{ mm}$ REJ.
8.4.9	MINOR	CHIPPING (ON THE TERMINAL SURFACE)	 $Y > (1/3) T$ REJ.
8.4.10	MINOR	CHIPPING	 $Y > T$ REJ.

