

THIS DRAWING IS UNPUBLISHED. RELEASED FOR PUBLICATION 2011
 © COPYRIGHT 2011 ALL RIGHTS RESERVED.

LOC		DIST		REVISIONS			
P	LTR	DESCRIPTION	DATE	DWN	APVD		
GP	00						
	B	REDRAWN PER ECO-12-008266	27AUG2012	CJV	CWR		
	C	REVISED PER ECO-13-007439	09JUL2013	CJV	CWR		
	D	REVISED PER ECO-15-007873	20JUN2015	AP	SB		

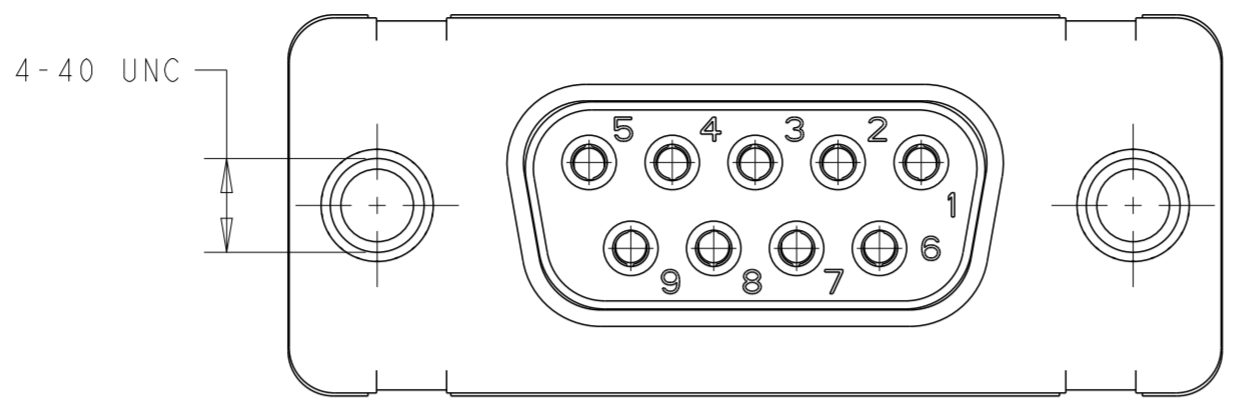

FLANGES WITH 4-40 UNC SELF-LOCKING NUTS TORQUE RETENTION ≥80NCM

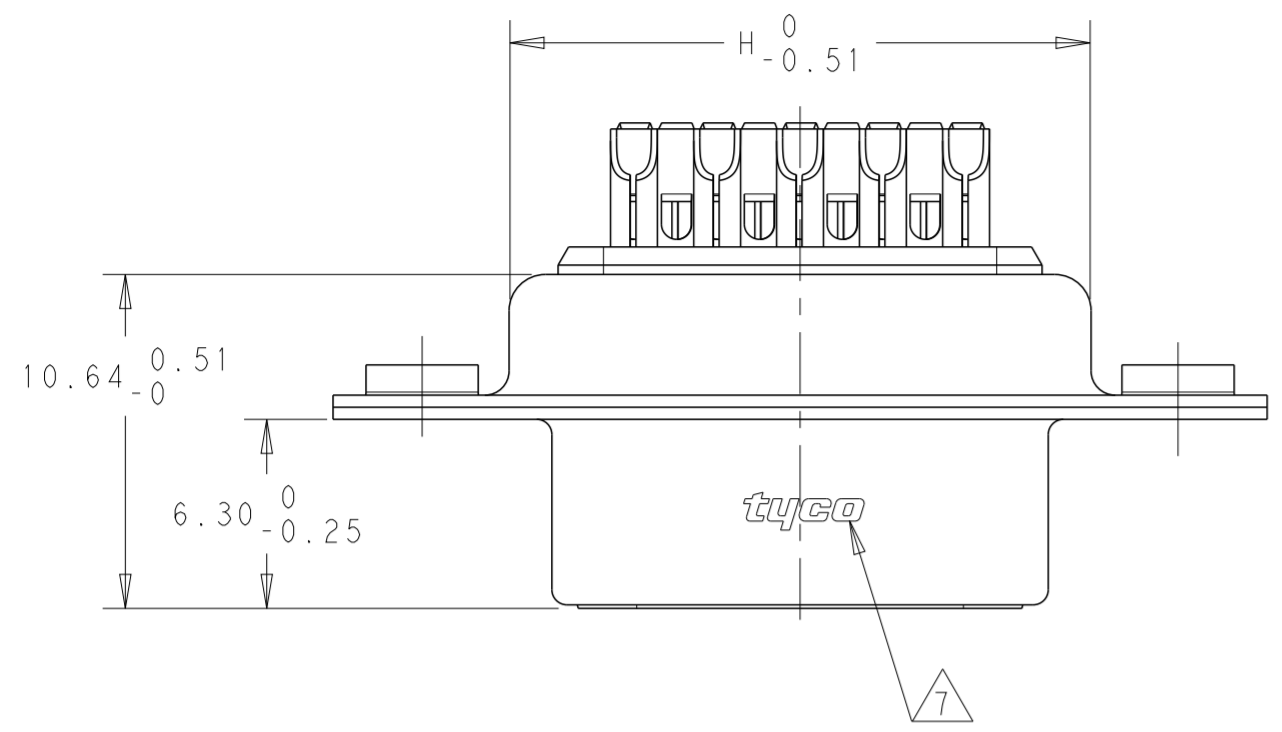
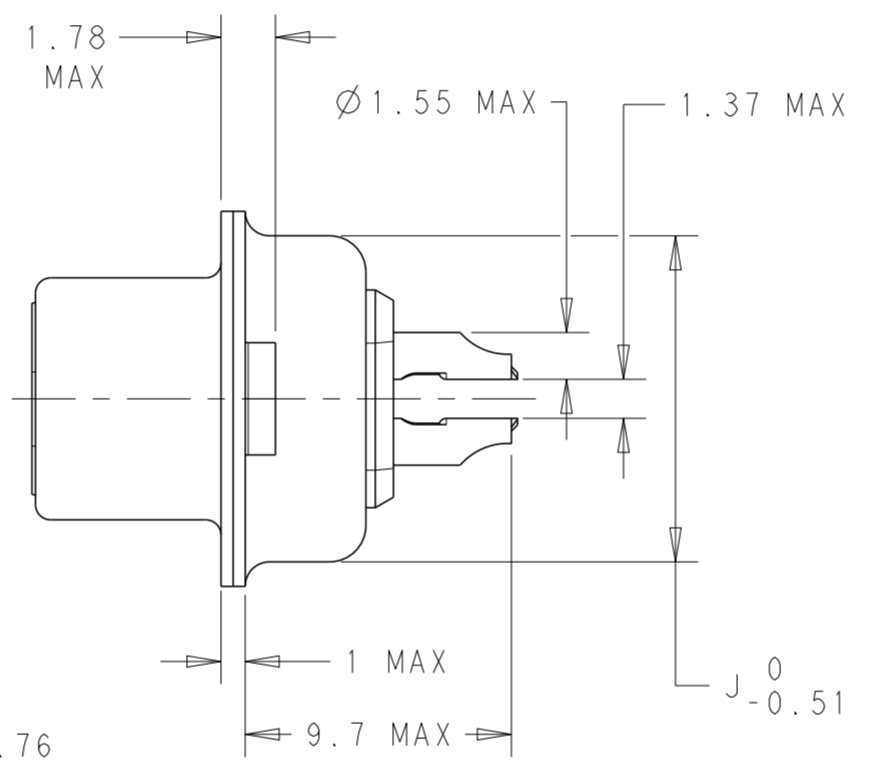
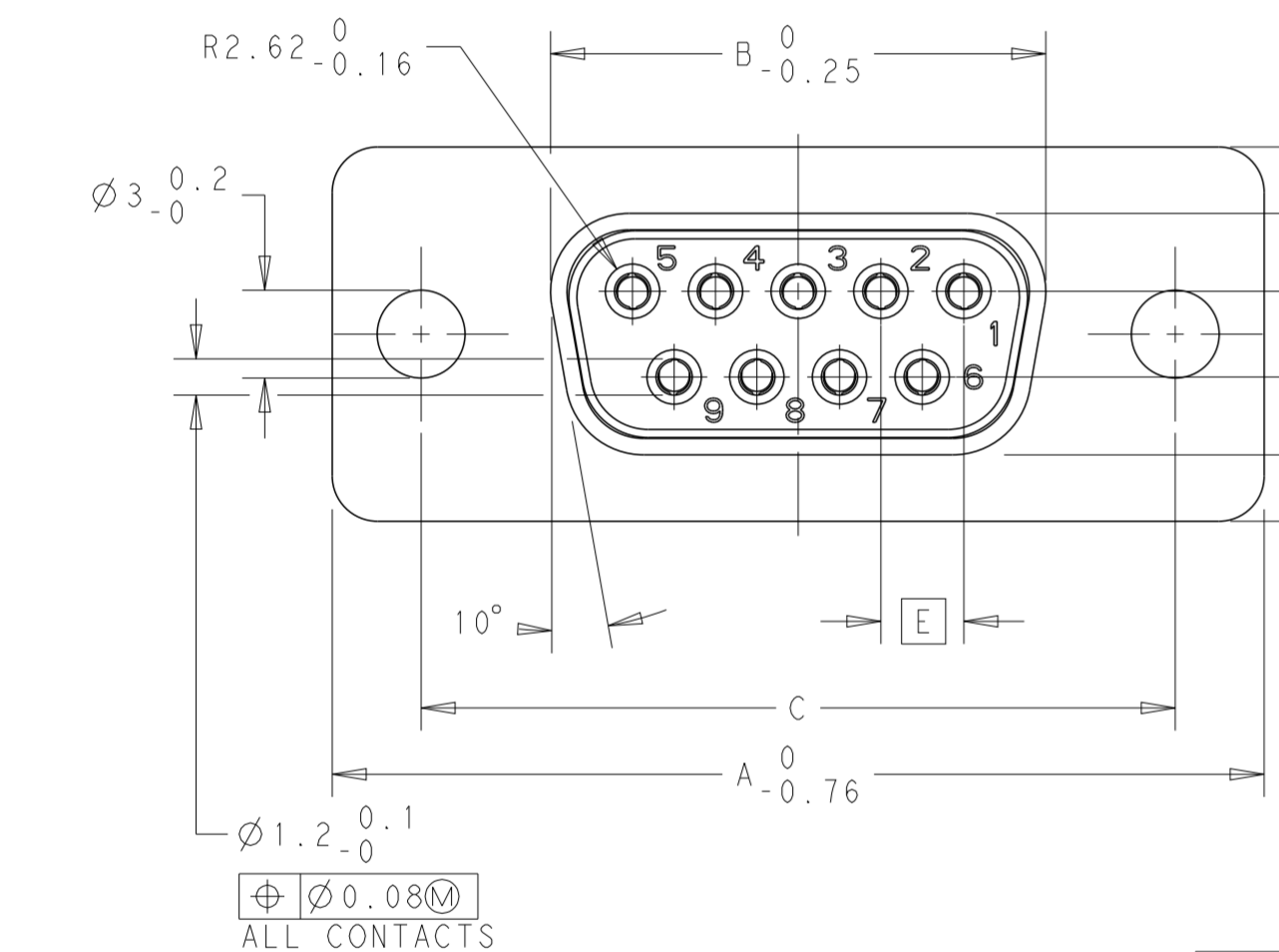
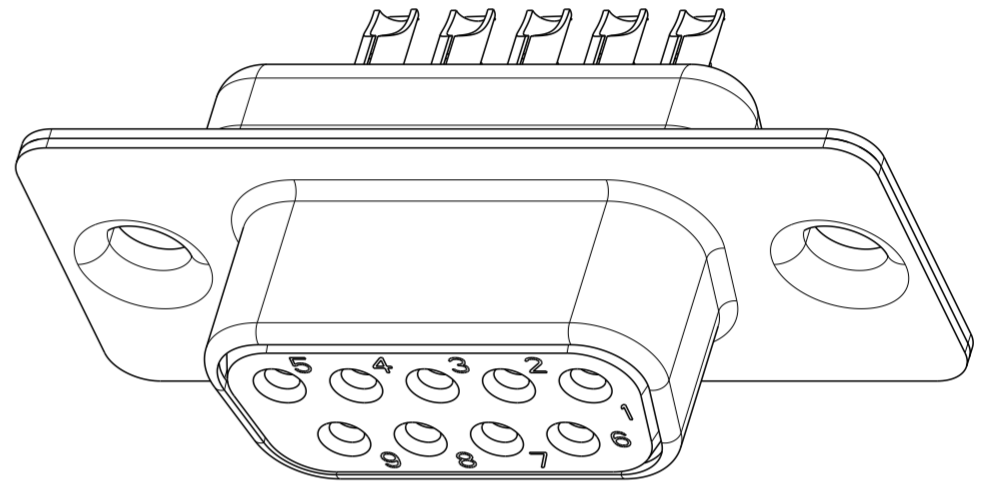
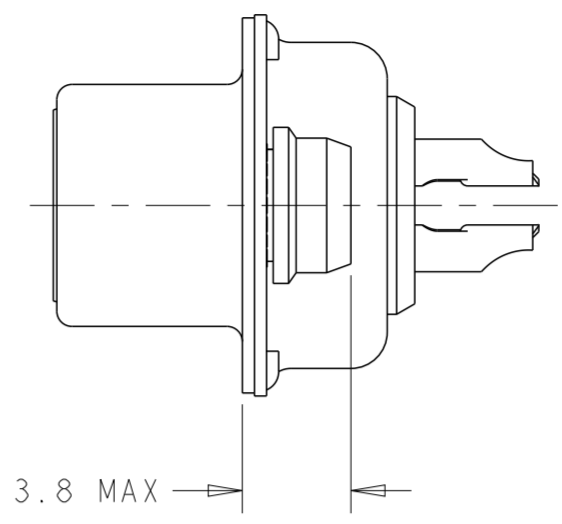

- 9 POSITION VERSION SHOWN.
 - CONTACTS ARE STAMPED AND FORMED.
 - PACKAGED IN BLISTER PACKS.
 - PLATING DETAILS: ALL MEET PERFORMANCE LEVEL INDICATED IN TABLE PER DIN 41652.
 UNDERPLATE: NICKEL OVER ENTIRE CONTACT
 PERFORMANCE LEVEL 1 CONTACT MATING SURFACE: GOLD
 PERFORMANCE LEVEL 2 CONTACT MATING SURFACE: GOLD
 SOLDER CUP END: MATTE TIN
 SHELL PLATING: BRIGHT TIN OVER NICKEL
 - 50 CONTACT VERSION HAS 3 ROWS.
 - 4-40 UNC INSERTS COLORED BLUE.
- △ ALL PARTS MARKED WITH TE LOGO.

⊕ ⌀0.08M ALL CONTACTS

FLANGES WITH HOLES

OBSOLETE	2	3.0 DIAMETER HOLE	67.31	52.55	61.10 +0.14/-0.11	10.87	15.75	2.76	55.58	13.82	50	V42254-A1115-B250	1393740-7
	2	3.0 DIAMETER HOLE	69.70	54.96	63.50 ±0.13	8.02	12.93	2.76	57.96	10.97	37	V42254-A1115-B237	4-1393483-1
	2	3.0 DIAMETER HOLE	53.42	38.50	47.04 ±0.13	8.02	12.93	2.76	41.53	10.97	25	V42254-A1115-B225	4-1393483-0
	2	3.0 DIAMETER HOLE	39.52	24.79	33.30 +0.15/-0.10	8.02	12.93	2.74	27.76	10.97	15	V42254-A1115-B215	3-1393483-9
OBSOLETE	2	3.0 DIAMETER HOLE	31.19	16.46	25.00 +0.12/-0.13	8.02	12.93	2.74	19.53	10.97	9	V42254-A1115-B209	3-1393483-8
	1	3.0 DIAMETER HOLE	53.42	38.50	47.04 ±0.13	8.02	12.93	2.76	41.53	10.97	25	V42254-A1115-B125	3-1393483-7
	1	3.0 DIAMETER HOLE	31.19	16.46	25.00 +0.12/-0.13	8.02	12.93	2.74	19.53	10.97	9	V42254-A1115-B109	3-1393483-6
	2	4-40 SELF-LOCKING NUTS	69.70	54.96	63.50 ±0.13	8.02	12.93	2.76	57.96	10.97	37	V42254-A1112-B237	2-1393483-2
	2	4-40 SELF-LOCKING NUTS	53.42	38.50	47.04 ±0.13	8.02	12.93	2.76	41.53	10.97	25	V42254-A1112-B225	2-1393483-1
	2	4-40 SELF-LOCKING NUTS	39.52	24.79	33.30 +0.15/-0.10	8.02	12.93	2.74	27.76	10.97	15	V42254-A1112-B215	2-1393483-0
	2	4-40 SELF-LOCKING NUTS	31.19	16.46	25.00 +0.12/-0.13	8.02	12.93	2.74	19.53	10.97	9	V42254-A1112-B209	1-1393483-9
PERFORMANCE LEVEL		FLANGE OPTION	A	B	C	D	E	F	H	J	NO OF POSITIONS	SIEMENS PART NUMBER	TE CONNECTIVITY PART NUMBER

THIS DRAWING IS A CONTROLLED DOCUMENT. DIMENSIONING AND TOLERANCING PER ASME Y14.5M-2009

DIMENSIONS:	TOLERANCES UNLESS OTHERWISE SPECIFIED:
mm	
0 PLC	±
1 PLC	±
2 PLC	±
3 PLC	±
4 PLC	±
ANGLES	±1°
FINISH	

DWN	06MAR2012
CHK	RAGHAVENDRA
CHK	CARL ROHDE
APVD	06MAR2012
APVD	CARL ROHDE
PRODUCT SPEC	
APPLICATION SPEC	
WEIGHT	
CUSTOMER DRAWING	

STE TE Connectivity

D-SUB SOLDERING LUGS, FEMALE CONNECTOR

SIZE: A2 CAGE CODE: 00779 DRAWING NO: C-1-1393483-9 RESTRICTED TO: -

SCALE: 4:1 SHEET 1 OF 1 REV D