

THIS DRAWING IS UNPUBLISHED. RELEASED FOR PUBLICATION
 © COPYRIGHT - TE Connectivity ALL RIGHTS RESERVED.

SPECIFICATIONS:

REVISIONS				
P	LTR	DESCRIPTION	DATE	APVD
B1		REVISED PER ECO-17-002272	20JUN2017	SK AS

MATERIALS:
 FRAME: STEEL
 ACTUATOR: ACETAL
 INSULATOR: PHENOL, BLUE
 TERMINAL: COPPER ALLOY, SILVER PLATE
 SPRING PLATE: COPPER ALLOY
 COIL SPRING: PIANO WIRE
 CAM STICK: COPPER ALLOY
 CLIP: COPPER ALLOY, SILVER CLAD
 SPRING STOPPER: STEEL
 CAP: MATERIAL SPECIFICATION PER DRAWING # 11882

ELECTRICAL:
 CONTACT RATING: 1 AMP @ 25 VDC (RESISTIVE LOAD)
 INITIAL CONTACT RESISTANCE: 100 MILLIOHMS
 CONTACT RESISTANCE: 300 MILLIOHMS MAX.
 INSULATION RESISTANCE: 100 MEGOHMS MINIMUM @ 500 VDC
 DIELECTRIC STRENGTH: 500 VAC FOR 1 MINUTE
 CONTACT TIMING: NON SHORTING.

MECHANICAL:
 OPERATING FORCE: 300 ±150 GRAMS
 ACTUATOR TRAVEL: 2.3 MM (.091")
 LIFE EXPECTANCY: 10,000 CYCLES

ENVIRONMENTAL:
 OPERATING TEMPERATURE: -30°C TO +85°C (-22°F TO +185°F).

NOTES: UNLESS OTHERWISE SPECIFIED

1. INTERPRET DRAWING PER ASME Y14.5M 1994.
2. SEE AIDSHEET 91439F-1 FOR CAP PRESS FIT DETAILS.
3. BAR CODE LABELING: REFER TO AUGAT SPEC.304-09 & 304-10 FOR BAR CODE LABEL REQUIREMENTS.
4. PACKAGING: PLACE 4 BAGS OF 500 SWITCHES EACH IN ONE OUTER BOX. PLACE A CORRUGATED CARDBOARD SHEET IN BETWEEN EACH BAG AND ON TOP AND BOTTOM OF OUTER BOX BEFORE SEALING.
5. CAP SUPPLIED BY THOMAS & BETTS.

CIRCUIT DIAGRAM

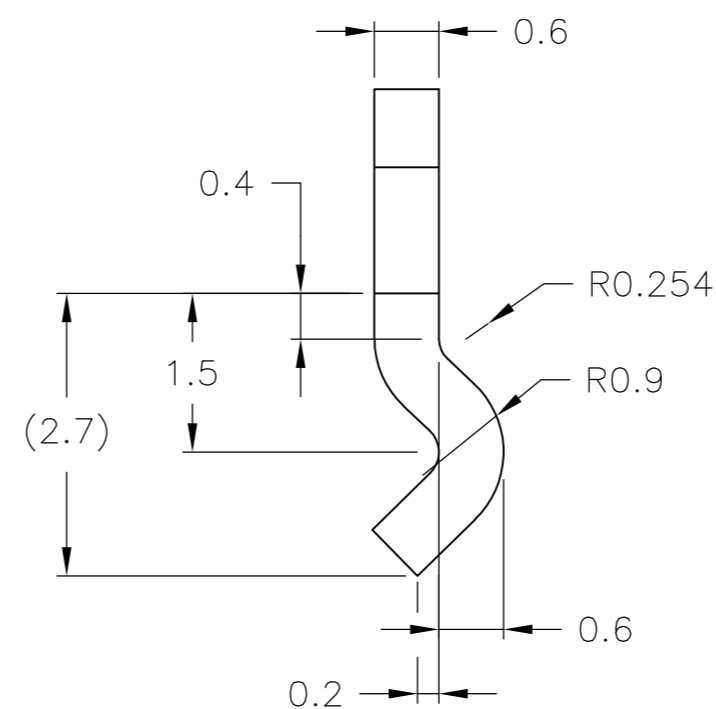
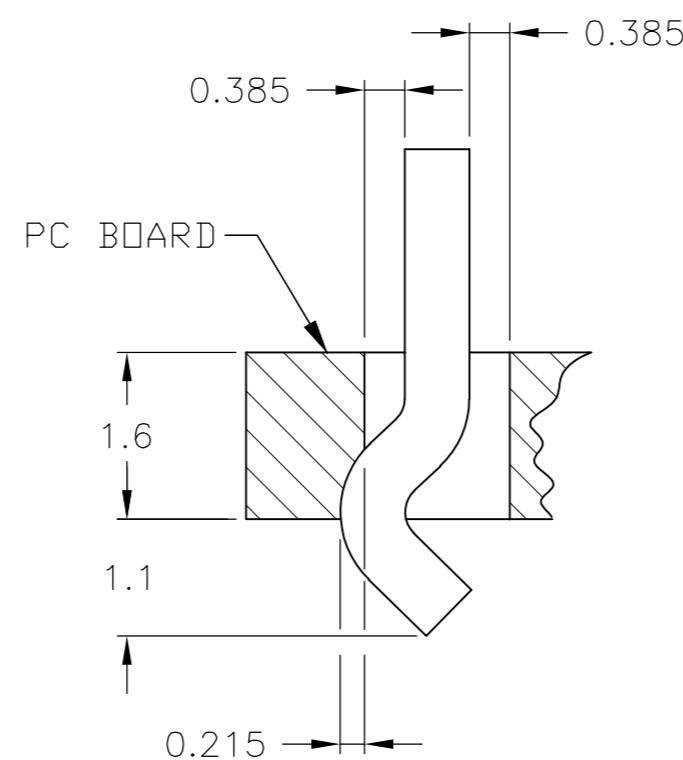
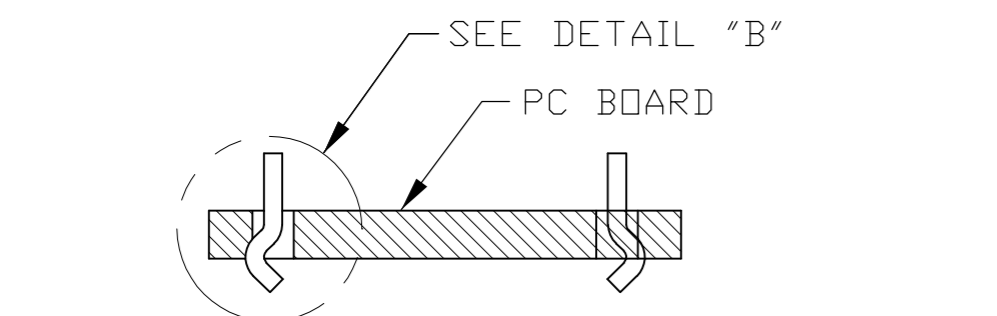
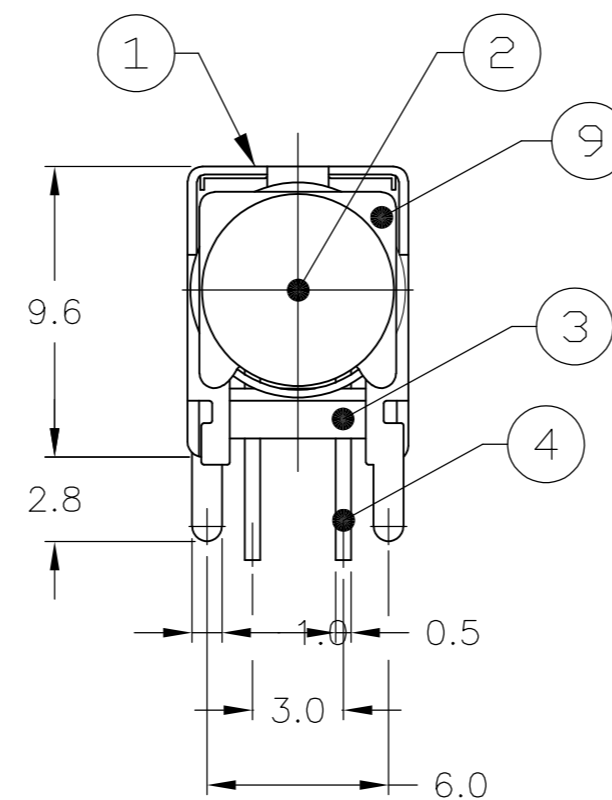
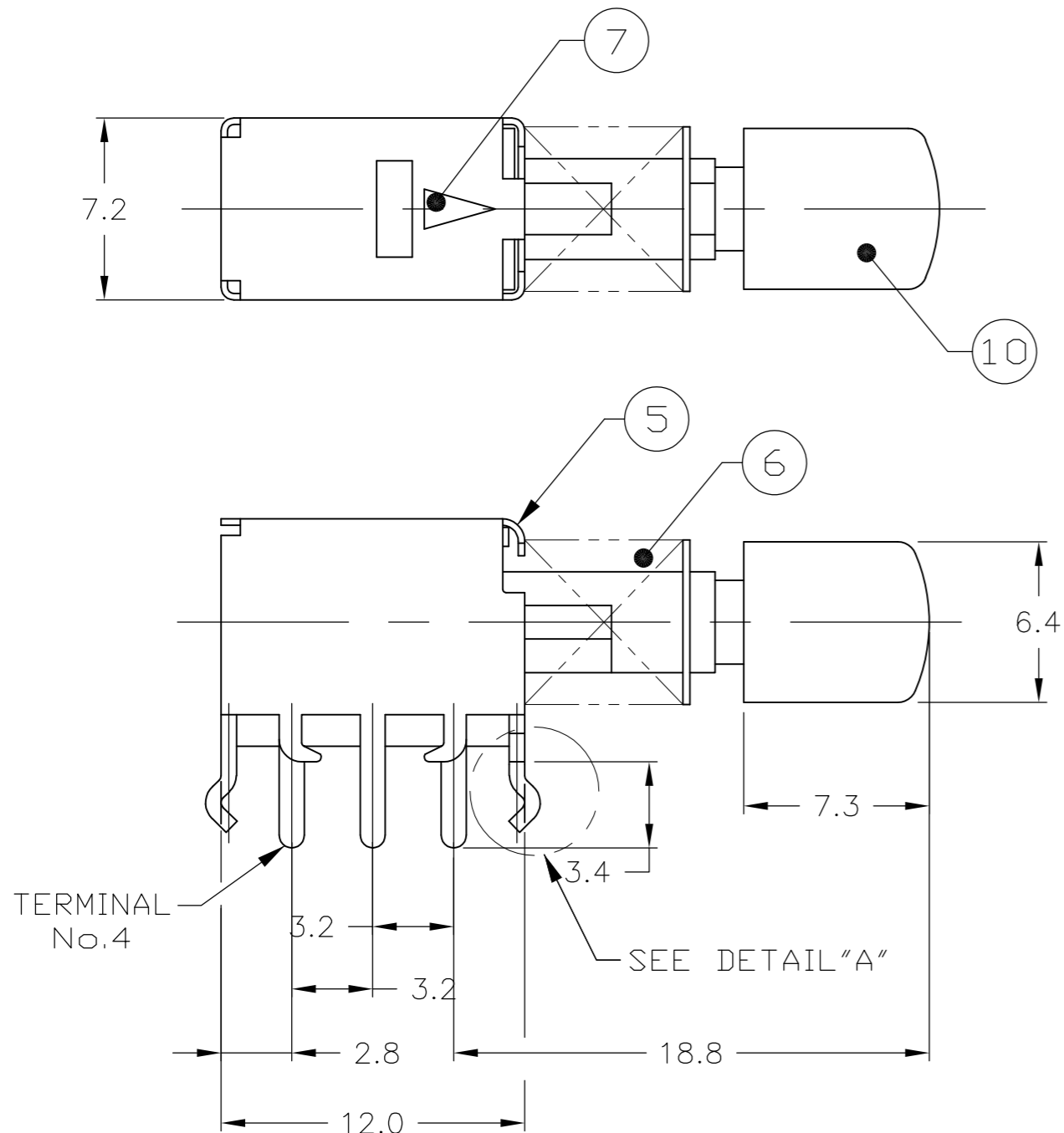
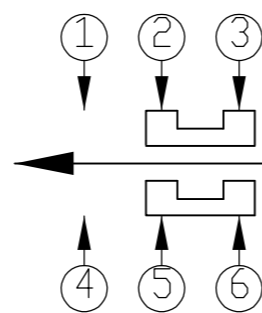

OBSLOETE

CAP PART NO.	BUTTON COLOR	CUSTOMER PART NO.	AUGAT PART NO.
USR0	BLACK	1.021.163	JLS91439FKBC
USR9	GRAY	1.021.081	JLS91439FK
USR1	WHITE	1.036.0048-00	JLS91439FWC

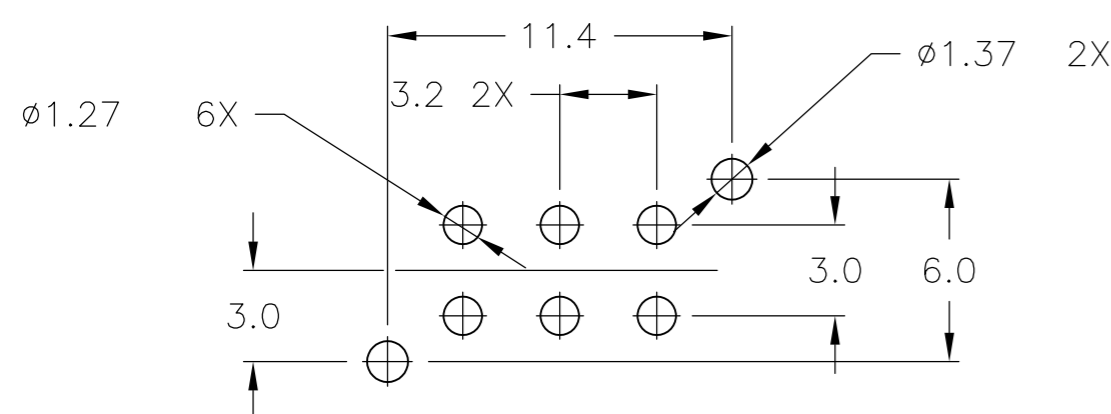

P.C.B. LAYOUT
 TOLERANCES ±0,05

DETAIL B
 SCALE 14:1

DETAIL A
 SCALE 14:1
 TOLERANCE: ±0,08

QTY.	DESCRIPTION	ITEM NO.
1	CAP	10
1	SPRING STOPPER	9
2	CLIP (NOT SHOWN)	8
1	CAM STICK	7
1	COIL SPRING	6
1	SPRING PLATE	5
1	TERMINAL	4
1	INSULATOR	3
1	ACTUATOR	2
1	FRAME	1

THIS DRAWING IS A CONTROLLED DOCUMENT.		DWN M.BINNER 18JAN2006		
DIMENSIONS: mm		CHK M.ZITTO 18JAN06		
TOLERANCES UNLESS OTHERWISE SPECIFIED:		APVD M.ZITTO 18JAN06	NAME PUSH SWITCH, JLS SERIES	
0 PLC ± -		PRODUCT SPEC	SIZE A2	
1 PLC ± -		APPLICATION SPEC	CAGE CODE 00779	
2 PLC ± 0.25			DRAWING NO C=1437566-7	
3 PLC ± -			RESTRICTED TO	
4 PLC ± -				
ANGLES ± .5°				
FINISH		WEIGHT 0.000000	SCALE 1:1	
MATERIAL		CUSTOMER DRAWING	SHEET 1 OF 1	
			REV B1	