

# Atmel LED Drivers

## MSL3167/MSL3168

16-string, White LED Drivers with Adaptive Power Control,  
Simple PWM Dimming Interface, and Fault Handling

Datasheet Brief



# Atmel LED Drivers-MSL3167/MSL3168

16-string, White LED Drivers with Adaptive Power Control, Simple PWM Dimming Interface, and Fault Handling

## General Description

The Atmel® LED Drivers-MSL3167 and MSL3168 compact, high-power, 16 parallel string LED drivers feature internal current control MOSFETs that can sink up to 30mA per LED string with better than 3% accuracy. These devices drive up to 10 white LEDs per string, for up to 160 LEDs per MSL3167/8. A single PWM input controls the PWM period and duty cycle for all strings.

**Note:** This MSL3167/8 Datasheet Brief explains direct drive PWM use of the device, including control of a single, external string power supply. The device is configured to operate this way automatically at power-up. The MSL3187/8 offer extended features not explained in this Datasheet Brief that include additional fault reporting and management, an I<sup>2</sup>C serial interface, and programmable power-up state. For information about these and other MSL3187/8 features, refer to the full MSL3187/8 Datasheet.

The MSL3167/8 includes automatic fault management of string open circuit, short circuit and over-temperature conditions. Faults are alerted on the FLT pin, and fault status is optionally available through the I<sup>2</sup>C/SMBus-compatible serial interface.

The MSL3167/8 adaptively controls the DC-DC converter that powers the LED strings using Atmel Adaptive SourcePower® technology. This Efficiency Optimizer minimizes power use while maintaining LED current accuracy.

A single, external resistor provides the global reference current for all the LED strings. The MSL3167 operates all 16 strings in phase, while the MSL3168 calculates and applies a 1/16th PWM period delay to successive strings to evenly spread the string power supply load across time.

The MSL3167/8 are offered in a wave-solderable, 32-pin SOP package (1.27mm pin pitch) and operate over a -40°C to +105°C temperature range.

## Applications

### Long Life, Efficient LED Backlighting for:

- Televisions and Desktop Monitors
- Medical and Industrial Instrumentation
- Automotive Audio-visual Displays

## Ordering Information

PART	DESCRIPTION	PACKAGE
MSL3167GU	16-Ch LED driver with in-phase strings	32-pin SOP, 1.27mm pin pitch
MSL3168GU	16-Ch LED driver with auto-phased strings	32-pin SOP, 1.27mm pin pitch

# Atmel LED Drivers-MSL3167/MSL3168

16-string, White LED Drivers with Adaptive Power Control, Simple PWM Dimming Interface, and Fault Handling

## Key Features

- Drives 16 Parallel LED Strings of 10 White LEDs Each
- Up to 30mA LED String Current
- Adaptive Power Optimizer Minimizes Power Use
- Automatic Open Circuit and Short Circuit Fault Management
- Single Resistor Sets Maximum Current for all Strings
- $\pm 3\%$  Current Accuracy and Current Balance
- Less than  $10\mu\text{A}$  String-off Leakage Current
- LED Intensity Controlled by PWM Input
- Single PWM Input Sets LED Period and Duty Cycle
- Automatic LED String Phase Delay of 1/16th PWM Period per String Spreads LED String Power Supply Load (MSL3168)
- Enable Input Allows Low-power Shutdown
- 1MHz I<sup>2</sup>C/Smbus-compatible Interface Monitors Status, but is not Required for Operation
- Wave-solderable SOP Package ( 1.27mm Pitch )
- $-40^{\circ}\text{C}$  To  $+105^{\circ}\text{C}$  Operating Temperature Range
- Over-temperature Shutdown with Automatic Wake-up

## Application Circuit

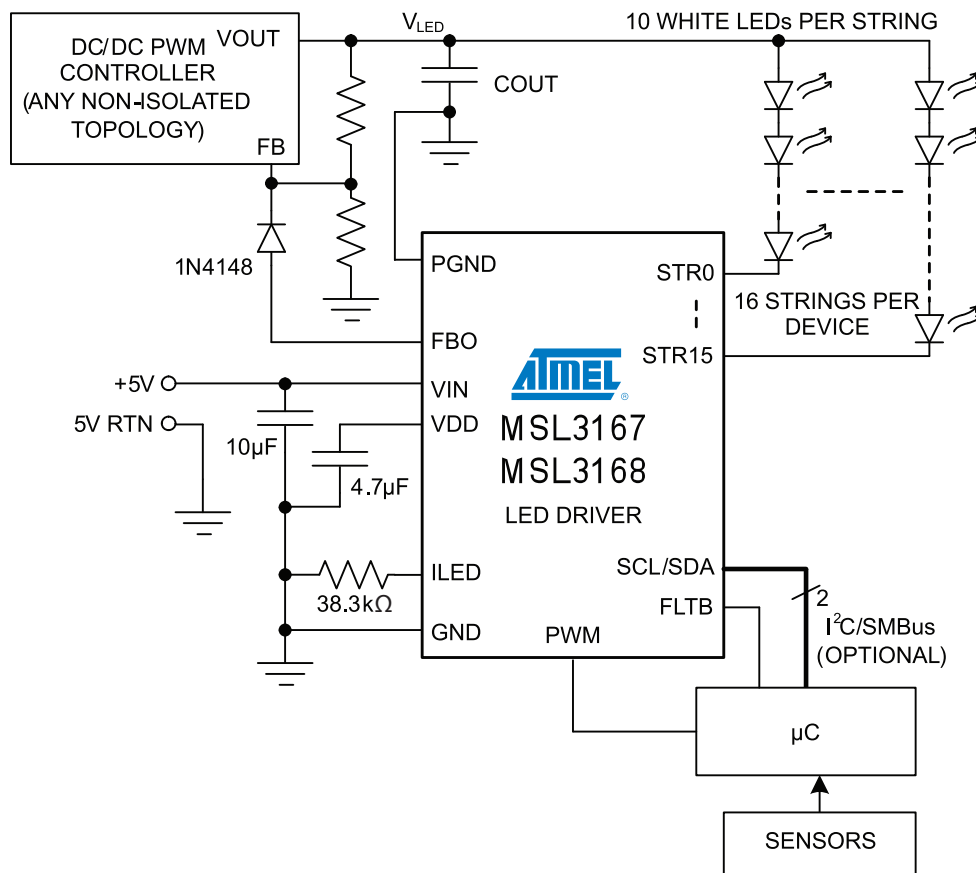



## Package Pin-outs and Dimensions

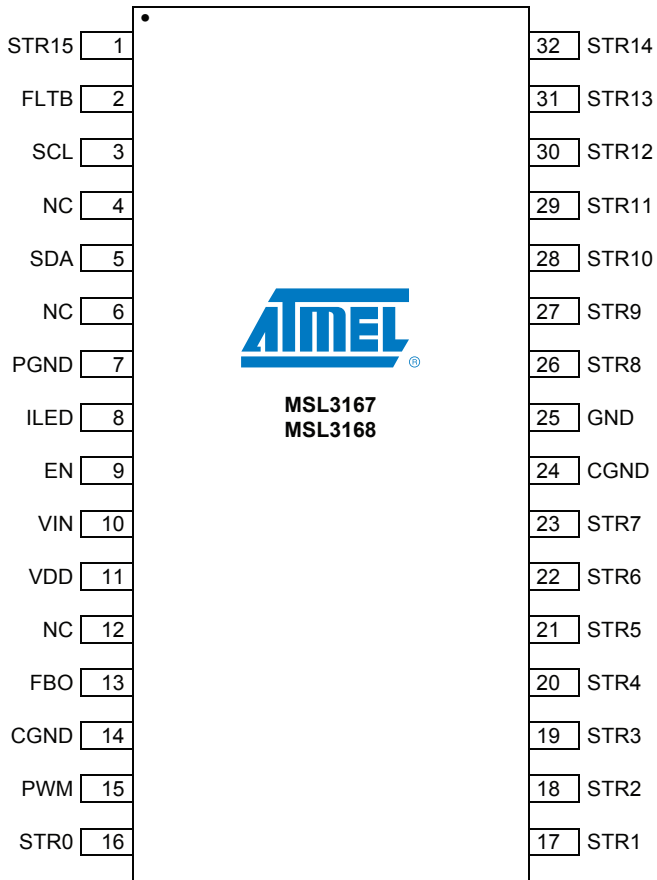

Figure 1. Atmel LED Drivers-MSL3167/8 Pin-out, 32-pin SOP.

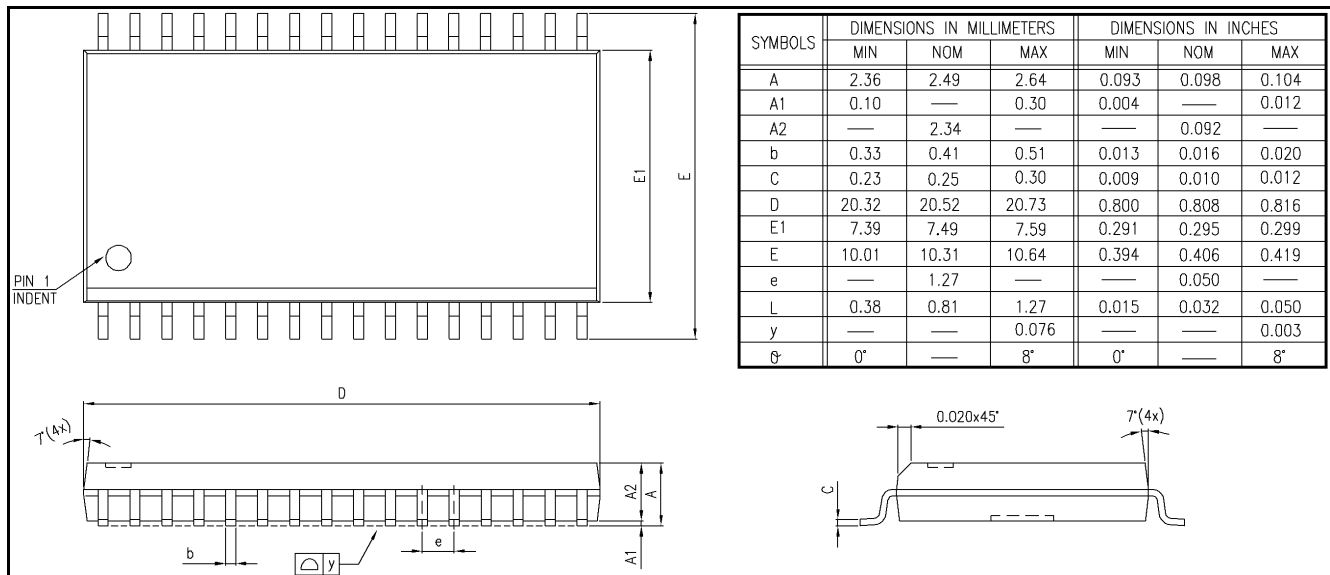

Figure 2. Package Dimensions: 32-pin, 20.52mm x 7.49mm x 2.49mm SOP (1.27mm Pin Pitch).

# Atmel LED Drivers-MSL3167/MSL3168

16-string, White LED Drivers with Adaptive Power Control,  
Simple PWM Dimming Interface, and Fault Handling

## Pin Description

Table 1. Pin Descriptions

PIN #	NAME	DESCRIPTION
1, 16 - 23, 26 - 32	STR0 thru STR15	<b>LED strings STR0 thru STR15 current sink outputs</b> Connect the cathode of the n <sup>th</sup> string's bottom LED to STRn. Connect unused STRn outputs to GND.
2	FLT B	<b>Fault indication output, active low</b> FLT B sinks current to GND whenever the MSL3167/8 detect a string fault. When active, FLT B remains low until EN is forced low or power is cycled.
3	SCL	<b>I<sup>2</sup>C serial clock input</b> SCL is the clock input for the I <sup>2</sup> C serial interface. Connect to GND if unused.
4, 6, 12	NC	<b>No connection</b> Factory test. Make no connection to NC.
5	SDA	<b>I<sup>2</sup>C serial data I/O</b> SDA is the data I/O for the I <sup>2</sup> C serial interface. Connect to GND if unused.
7	PGND	<b>Power ground</b> PGND is the path that the STRn sink currents take to ground. Connect PGND to the ground of the string power supply with wide traces. Also, connect PGND to EP for the TQFN packaged device.
8	I <sub>LED</sub>	<b>String maximum current setting input</b> Connect a resistor from I <sub>LED</sub> to GND to set the full-scale LED string current. See the section, "Setting the Maximum LED String Current with R <sub>I<sub>LED</sub></sub> " on page 11 for information about sizing the resistor.
9	EN	<b>Enable input (active high)</b> Force EN high to turn on the MSL3167/8. Force EN low to turn off the MSL3167/8 and to clear FLT B. For automatic start-up, connect EN to VIN.
10	VIN	<b>Supply voltage input</b> Connect a 5V supply to VIN. Bypass VIN to GND with a ceramic capacitor of at least 10µF placed close to VIN.
11	VDD	<b>2.5V internal LDO regulator output</b> VDD is the output of an internal linear regulator powered from VIN. VDD powers internal logic. Bypass VDD to GND with a ceramic capacitor of at least 4.7µF placed close to VDD.
13	FBO	<b>Efficiency Optimizer output</b> FBO sources current to the voltage divider of an external DC-DC converter to dynamically adjust the LED power supply for optimal efficiency.
14, 24	CGND	<b>Connect to GND</b> Connect CGND to GND.
15	PWM	<b>PWM dimming input</b> Drive PWM with a pulse-width modulated signal with duty ratio ranging from 0% to 100% and frequency from 20Hz to 50kHz to control the brightness of all LED strings.
25	GND	<b>Signal ground</b> GND is the ground reference for VDD, VIN, and the serial interface.
-	EP	<b>Exposed pad</b> Connect EP to PGND with a short, wide trace. EP provides a path to ground for the string currents, and also provides thermal relief for the die.



## Absolute Maximum Ratings

### Voltage (With Respect to GND, PGND = GND)

VIN, EN.....	-0.3V to +6V
VDD.....	-0.3V to +2.75V
SDA, SCL, FLTB.....	-0.3V to +6V
PWM, FBO.....	-0.3V to (VIN + 0.3V)
I <sub>LED</sub> .....	-0.3V to (VDD + 0.3V)
STR0 thru STR15.....	-0.3V to +40V
CGND.....	-0.3V to +0.3V

### Current (Into Pin)

VIN.....	50mA
STR0 thru STR15.....	45mA
PGND.....	-720mA
All other pins.....	20mA

### Continuous Power Dissipation

32-pin SOP (derate 28.7mW/°C above T<sub>A</sub> = +70°C) ..... 1576mW

**Ambient Operating Temperature Range T<sub>A</sub> = T<sub>MIN</sub> to T<sub>MAX</sub>** ..... **-40°C to +85°C**

**Junction Temperature** ..... **+125°C**

**Storage Temperature Range**..... **-65°C to +125°C**

**Lead Soldering Temperature, 10s** ..... **+300°C**

## Electrical Characteristics

Typical application circuit, VIN = 5V, T<sub>A</sub> = T<sub>MIN</sub> to T<sub>MAX</sub>, unless otherwise noted. Typical values are at VIN = 5V, T<sub>A</sub> = +25°C

PARAMETER	SYMBOL	CONDITIONS AND NOTES	MIN	TYP	MAX	UNIT	
<b>DC ELECTRICAL CHARACTERISTICS</b>							
VIN operating supply voltage	VIN		4.75	5	5.50	V	
VIN operating supply current	I <sub>VIN</sub>	EN = VIN, SLEEP = 0, R <sub>I<sub>LED</sub></sub> = 38.3kΩ, ISTR = 0xFF, PWMDIRECT = 1, PWMGLBLEN = 0	50% duty		15	25	mA
			100% duty		19	29	
VIN shutdown supply current	I <sub>SHDN</sub>	EN = GND, SDA, SCL and PWM = GND		10		μA	
VIN sleep current	I <sub>SLEEP</sub>	EN = 1, SLEEP = 1, SDA, SCL, PWM = GND or VDD		1.5		mA	
VDD regulation voltage	VDD		2.4	2.5	2.6	V	

# Atmel LED Drivers-MSL3 167/MSL3 168

16-string, White LED Drivers with Adaptive Power Control,  
Simple PWM Dimming Interface, and Fault Handling

PARAMETER	SYMBOL	CONDITIONS AND NOTES	MIN	TYP	MAX	UNIT
Input high voltage SDA, SCL, PWM	$V_{IH}$		0.7 x VDD			V
Input low voltage SDA, SCL, PWM	$V_{IL}$				0.3 x VDD	V
Input high voltage: EN			1.22			V
Input low voltage: EN					0.8	V
Output low voltage: SDA, FLTB	$V_{OL}$	$I_{SINK} = 5mA$			0.4	V
I <sub>LED</sub> regulation voltage		$R_{ILED} = 38.3k\Omega$		350		mV
FBO feedback output current		$V_{FBO} \leq VIN - 0.5V$	0		365	$\mu A$
FBO feedback output current step size				1.1		$\mu A$
STR0 thru STR15 sink current		$R_{ILED} = 38.3k\Omega, ISTR = 0xFF, V_{STRn} = 1V$	18	20	22	mA
STR0 to STR15 string sink current maximum		$R_{ILED} = 25.5k\Omega, ISTR = 0xFF$ (Note 1)		30		mA
STR0 to STR15 string-off leakage current					10	$\mu A$
STR0 thru STR15 current load regulation		$R_{ILED} = 38.3k\Omega, ISTR = 0xFF, FLDBKEN = 0, V_{STRn} = 1V$ to 5V		0.033		%/V
STR0 to STR15 current matching		$ISTR = 0xFF, R_{ILED} = 38.3k\Omega, V_{STRn} = 1V$	-5		5	%
STR0 to STR15 minimum headroom	$V_{STR}$	$R_{ILED} = 38.3k\Omega, ISTR = 0xFF$		150		mV
STR0 to STR15 short circuit fault detection threshold	$SC_{REF}$			8.4		V
STR0 thru STR15 current slew rate		Current rising (Note 2)		200		mA/ $\mu s$
		Current falling (Note 2)		8,000		
Thermal shutdown temperature		(Note 2)		135		$^{\circ}C$

PARAMETER	SYMBOL	CONDITIONS AND NOTES	MIN	TYP	MAX	UNIT
<b>AC ELECTRICAL CHARACTERISTICS</b>						
PWM frequency	$f_{PWM}$				50	kHz
PWM duty cycle			0		100	%
<b>I<sup>2</sup>C TIMING CHARACTERISTICS</b>						
SCL clock frequency	$1/t_{SCL}$	Bus timeout disabled (Note 3)	0		1	MHz
Bus timeout period	$t_{timeout}$	OSCCTRL = 0x04		30		ms
		$f_{OSC} = 16MHz$ to 23MHz		$600,000 / f_{OSC}$		s
STOP to START condition bus free time	$t_{BUF}$		0.5			$\mu s$
Repeated START condition hold time	$t_{HD:STA}$		0.26			$\mu s$
Repeated START condition setup time	$t_{SU:STA}$		0.26			$\mu s$
STOP condition set-up time	$t_{SU:STOP}$		0.26			$\mu s$
SDA data hold time	$t_{HD:DAT}$		0			ns
SDA data valid acknowledge time	$t_{VD:ACK}$	(Note 4)	0.05		0.45	$\mu s$
SDA data valid time	$t_{VD:DAT}$	(Note 5)	0.05		0.45	$\mu s$



PARAMETER	SYMBOL	CONDITIONS AND NOTES	MIN	TYP	MAX	UNIT
SDA data set-up time	$t_{SU:DAT}$		100			ns
SCL clock low period	$t_{LOW}$		0.5			$\mu s$
SCL clock high period	$t_{HIGH}$		0.26			$\mu s$
SDA, SCL fall time	$t_f$	(Note 6, Note 7)			120	ns
SDA, SCL rise time	$t_r$				120	ns
SDA, SCL input suppression filter period	$t_{SP}$	(Note 7)		50		ns

- Note 1. Subject to thermal dissipation characteristics of the device.
- Note 2. Guaranteed by design, and not production tested.
- Note 3. Minimum SCL clock frequency is limited by the bus timeout feature, which resets the serial bus interface if either SDA or SCL is held low for  $t_{timeout}$ . Disable bus timeout via the power control register, 0x02[6].
- Note 4.  $t_{VDACK}$  = SCL low to SDA (out) low acknowledge time.
- Note 5.  $t_{VDDAT}$  = minimum SDA output data-valid time following SCL low transition.
- Note 6. A master device must provide an SDA hold time of at least 300ns to ensure an SCL low state.
- Note 7. The maximum SDA and SCL rise and fall time specifications are influenced by the speed of operation required. The original Philips Corp. I<sup>2</sup>C specification allows slower values, but because the MSL3167/8 interface is designed to operate at speeds exceeding the original specification, these timing values have tightened up. Maximum bus speed is also influenced by bus capacitance. Lay out bus traces to minimize capacitance when high-speed operation is required.
- Note 8. MSL3167/8 include input filters on SDA and SCL inputs that suppress noise less than 50ns.

## Block Diagram

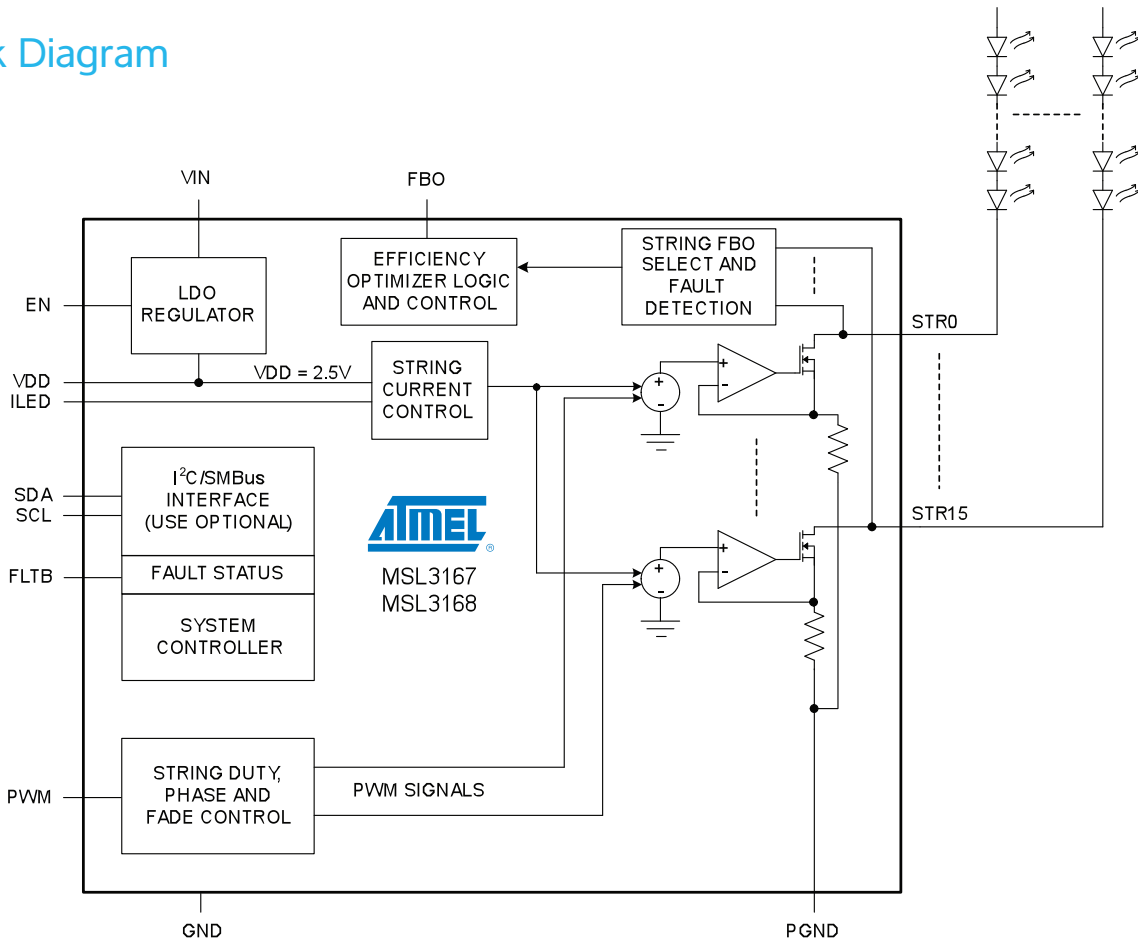



# Atmel LED Drivers-MSL3 167/MSL3 168

16-string, White LED Drivers with Adaptive Power Control,  
Simple PWM Dimming Interface, and Fault Handling

## Typical Application Circuit

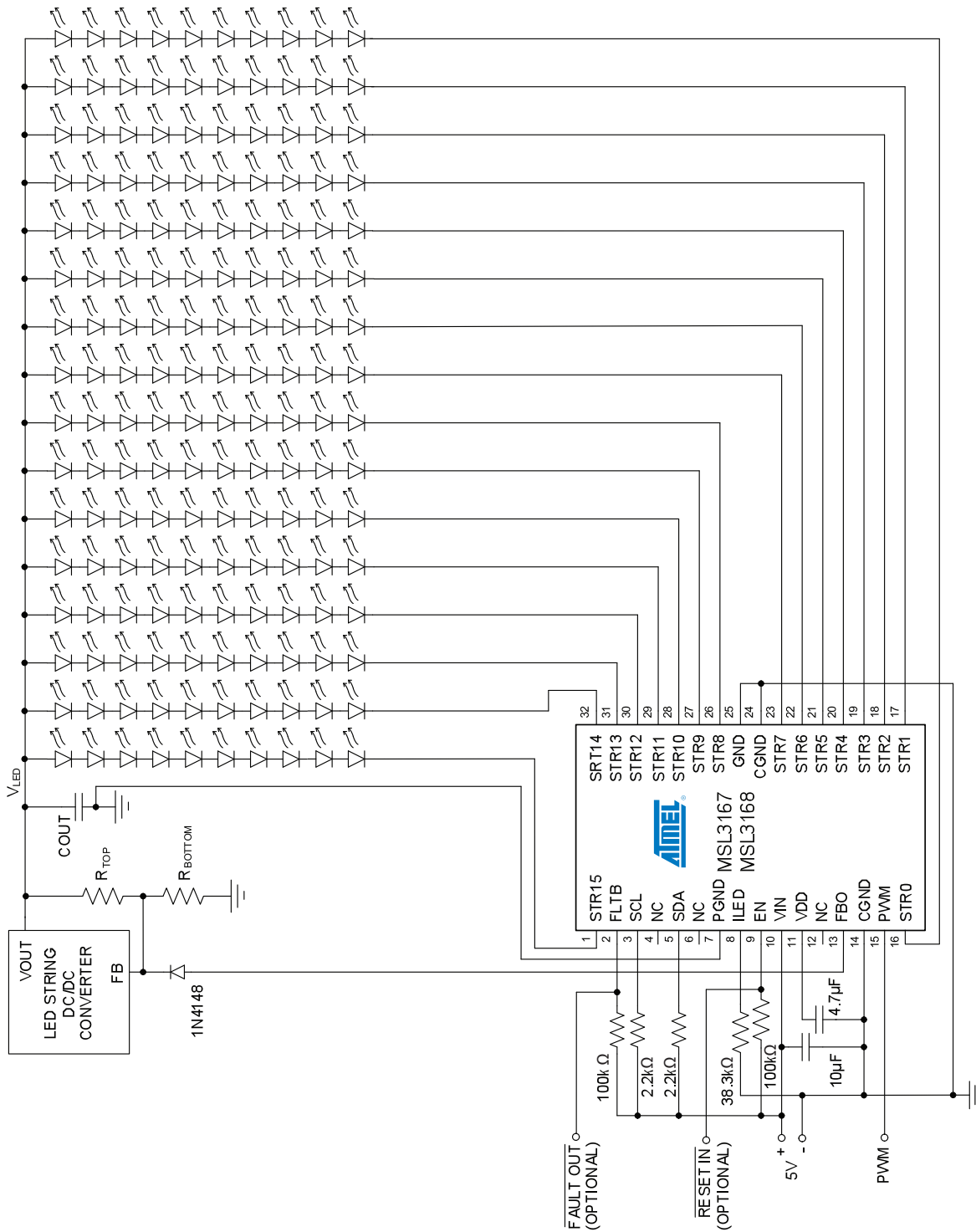

Figure 3. Atmel LED Drivers-MSL3 167/8 Driving 160 White LEDs in 16 Strings at 20mA per String.



## Detailed Description

The MSL3167/8 are multi-string LED drivers with power supply control that continually optimize system efficiency. A pulse width modulated signal applied to the PWM input sets the PWM frequency and duty cycle of all LED string drivers. The MSL3168 automatically calculates a phase delay of 1/16th of the PWM period and implements the delay successively to each string driver to reduce the transient load on the LED power supply. The MSL3167 applies the PWM input signal to all LED string outputs without phase delays.

The MSL3167/8 controls a wide range of external DC-DC and AC-DC converter architectures, and allows design of the string power supply for the worst case LED forward voltage drop ( $V_f$ ) without concern about excessive power dissipation issues. At start-up, the MSL3167/8 automatically reduces the power supply voltage to the minimum voltage required to keep the LEDs in current regulation. The MSL3167/8 then continually re-optimize the string power supply voltage to compensate for the changes in the LED strings' forward voltage drop due to temperature and aging.

The MSL3167/8 handles string and over-temperature faults automatically, and optionally interface to a host system with an I<sup>2</sup>C/SMBus-compatible interface for detailed fault monitoring and string control.

## Internal Regulators

The MSL3167/8 includes an internal 2.5V linear regulator (VDD), powered by VIN, which powers the low-voltage internal circuitry. Bypass VDD to GND with a ceramic capacitor of at least 4.7µF. Bypass VIN to GND with a ceramic capacitor of at least 10µF.

## The Enable Input

The MSL3167/8 enables input, EN, enables the device. Drive EN low to turn off all strings, to clear the fault output, FLTb, and to enter low power operation, which lowers quiescent current draw to 1.5mA (typical). With EN low, the serial interface is ignored and the FBO output current is zero. Drive EN high with a 5V logic signal to turn on the MSL3167/8. When EN changes from low to high, all bits in the control registers revert to their power-up default values, the fault registers are cleared, and the Efficiency Optimizer performs an initial calibration cycle. If unused, connect EN to VIN.

## String Phase Delay

The MSL3168 automatically calculates a phase delay of 1/16th of the PWM period and implements the delay successively to the string drive signals (Figure 4) to reduce the transient load on the LED power supply. The MSL3167 applies the PWM input signal to all LED string outputs without phase delays.

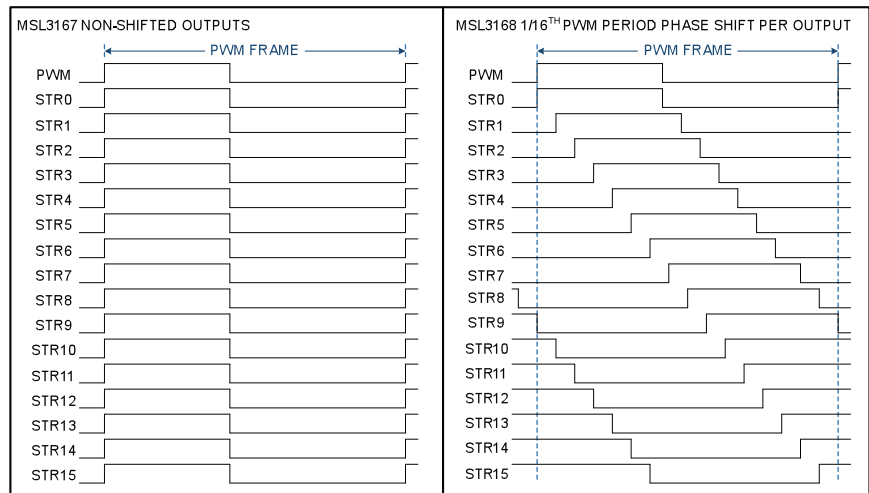

**Figure 4. Atmel LED Drivers-MSL3167/8 Examples of Non-shifted and Phase Shifted String Drive Signals.**

# Atmel LED Drivers-MSL3167/MSL3168

16-string, White LED Drivers with Adaptive Power Control,  
Simple PWM Dimming Interface, and Fault Handling

## Setting the Maximum LED String Current with $R_{ILED}$

The maximum string current,  $I_{ILED}$ , for all 16 LED strings is set by a single external resistor,  $R_{ILED}$ , placed from ILED to GND. Determine the value for  $R_{ILED}$  using:

$$R_{ILED} = \frac{762}{I_{ILED}}, \text{ where } I_{ILED} \text{ is in mA and } R_{ILED} \text{ is in k}\Omega.$$

For example, a full-scale maximum LED string current of 19.9mA returns  $R_{ILED} = 38.3\text{k}\Omega$ .

## Efficiency Optimizer

The Efficiency Optimizer (EO) improves power efficiency by injecting a current of between 0 and 255 $\mu\text{A}$  into the voltage divider of the external power supply (Figure 5), dynamically adjusting the power supply's output to the minimum voltage required by the LED strings. This ensures that there is sufficient voltage available for LED current control and good power supply noise rejection, while minimizing power dissipation. The power supply must have a nominal feedback voltage of no more than 3.5V, and the voltage setting resistor divider must be accessible (sizing the resistors is covered in the next section).

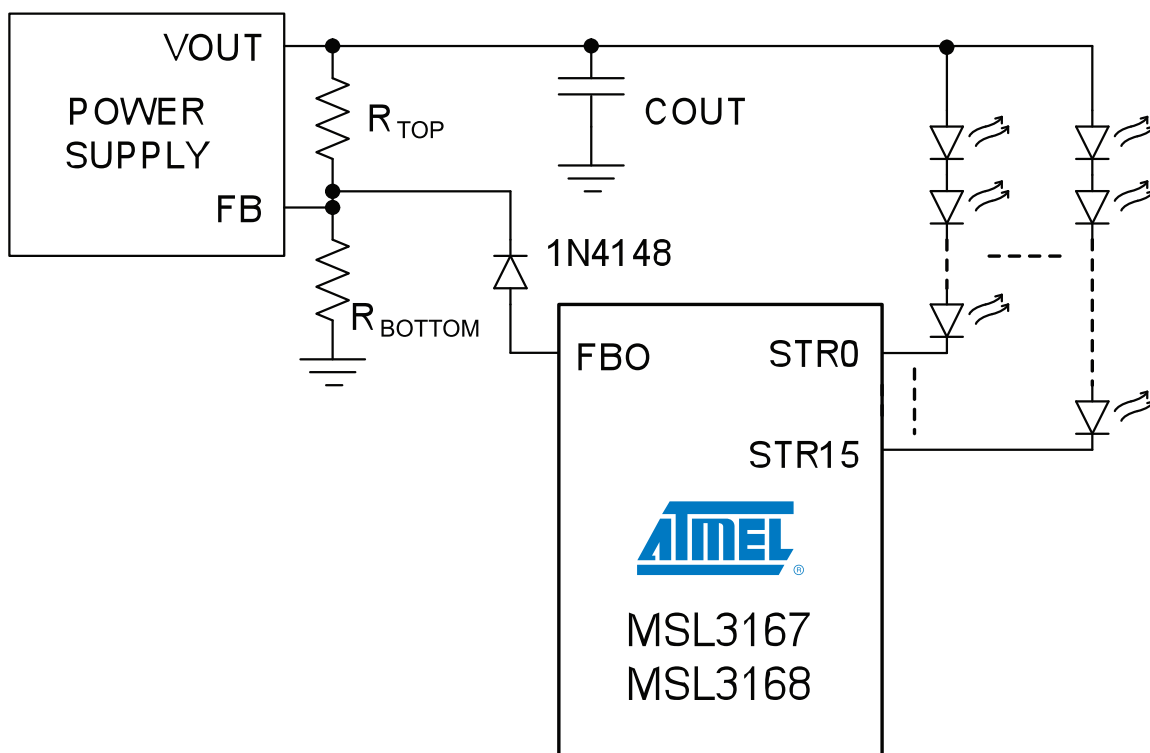

Figure 5. Atmel LED Drivers-MSL3167/8 FBO Connection to Power Supply Voltage Divider



## Determining the String Power Supply Feedback Resistors

The MSL3167/8 are designed to control LED string power supplies that use a voltage divider ( $R_{TOP}$  and  $R_{BOTTOM}$  in Figure 5) to set output voltage, and whose regulation feedback voltage is not more than 3.5V. To select the resistors, first determine  $V_{OUT(MIN)}$  and  $V_{OUT(MAX)}$ , the minimum and maximum string supply voltage limits, using:

$$V_{OUT(MIN)} = (V_{f(MIN)} * [\#ofLEDs]) + 0.5, \text{ and}$$

$$V_{OUT(MAX)} = (V_{f(MAX)} * [\#ofLEDs]) + 0.5,$$

where  $V_{f(MIN)}$  and  $V_{f(MAX)}$  are the LED's minimum and maximum forward voltage drops at the peak current set by  $R_{ILED}$  (page 9). For example, if the LED data are  $V_{f(MIN)} = 3.5V$  and  $V_{f(MAX)} = 3.8V$ , and 10 LEDs are used in a string, then the total minimum and maximum voltage drops across a string are 35V and 38V, respectively. Adding an allowance of 0.5V for the string drive MOSFET headroom brings  $V_{OUT(MIN)}$  to 35.5V and  $V_{OUT(MAX)}$  to 38.5V. Do not to exceed the 40V maximum specification of string drivers STR1 to STR15. Then, determine  $R_{TOP}$  using:

$$R_{TOP} = \frac{V_{OUT(MAX)} - V_{OUT(MIN)}}{I_{FBO(MAX)}}$$

where  $I_{FBO(MAX)}$  is the 255 $\mu$ A maximum output current of the Efficiency Optimizer output. Finally, determine  $R_{BOTTOM}$  using:

$$R_{BOTTOM} = R_{TOP} * \frac{V_{FB}}{V_{OUT(MAX)} - V_{FB}}$$

where  $V_{FB}$  is the regulation feedback voltage of the power supply. Place a diode (1N4148 or similar) between FBO and the supply's feedback node to protect the MSL3167/8 against current flow into FBO (Figure 5).

## Register Map and the EEPROM

### Register Map Summary

The MSL3167/8 are controlled using the 96 registers in the range 0x00 - 0x5F. It may be convenient, and it is allowed, to read and write to unused bits in this range when accessing registers, but do not change the default values of unused bits. Three additional registers, 0x90, 0x91, and 0x93, allow access to the EEPROM and provide Efficiency Optimizer status. The power-up default values for all control registers are stored within the on-chip EEPROM, and any of these EEPROM values may be changed through the serial interface, as detailed in the full MSL3187/8 datasheet.

**Table 2. Atmel LED Drivers-MSL3167/8 Register Map**

ADDRESS AND REGISTER NAME		FUNCTION	REGISTER DATA							
			D7	D6	D5	D4	D3	D2	D1	D0
0x00	CONTROL0	LED string enables	STR7EN	STR6EN	STR5EN	STR4EN	STR3EN	STR2EN	STR1EN	STR0EN
0x01	CONTROL1		STR15EN	STR14EN	STR13EN	STR12EN	STR11EN	STR10EN	STR9EN	STR8EN

# Atmel LED Drivers-MSL3 167/MSL3 168

16-string, White LED Drivers with Adaptive Power Control,  
Simple PWM Dimming Interface, and Fault Handling

ADDRESS AND REGISTER NAME		FUNCTION	REGISTER DATA							
			D7	D6	D5	D4	D3	D2	D1	D0
0x02	POWERCTRL	Fault configuration	SLEEP	I <sup>2</sup> CTOEN	PHIMINFEN	GSCMAXFEN	STRSCFEN	STROCFEN	FBOOCEN	FBOEN
0x03	FLTSTATUS	Fault status, global	-	-	PHIMINFLT	GSCMAXFLT	STRSCDET	STROCDDET	FBOOC	FLTDET
0x04	OCSTAT0	String open circuit fault status	OC7	OC6	OC5	OC4	OC3	OC2	OC1	OC0
0x05	OCSTAT1		OC15	OC14	OC13	OC12	OC11	OC10	OC9	OC8
0x06	SCSTAT0	String short circuit fault status	SC7	SC6	SC5	SC4	SC3	SC2	SC1	SC0
0x07	SCSTAT1		SC15	SC14	SC13	SC12	SC11	SC10	SC9	SC8
0x08	FLTMASK0	String fault masks	FLTEN7	FLTEN6	FLTEN5	FLTEN4	FLTEN3	FLTEN2	FLTEN1	FLTEN0
0x09	FLTMASK1		FLTEN15	FLTEN14	FLTEN13	FLTEN12	FLTEN11	FLTEN10	FLTEN9	FLTEN8
0x0A	FBOCTRL0	Efficiency Optimizer control	HDRMSTEP[1:0]		FBCLDLY[1:0]		FBSLDLY[1:0]		FBCFDLY[1:0]	
0x0B	FBOCTRL1		SCCDLY[1:0]		DECRSTEP[1:0]		INITPWM	ACAL100	ACALEN	ICHKDIS
0x0C	FBODAC	Efficiency Optimizer DAC readback	FBODAC[7:0]							
0x0D– 0x0E		UNUSED	UNUSED							
0x0F	ISTR	8-bit global string current	ISTR[7:0]							
0x10	OSCCTRL	Oscillator frequency	-	-	-	-	-	OSCCTRL[2:0]		
0x11	GSCCTRL	GSC processing control	GSCCHK-SEL	-	-	-	GSCMAXEN	-	-	-
0x12	GSCGEN	GSC clock generator	GSCGEN[7:0]							
0x13			GSCGEN[15:8]							
0x14	GSCMUL	GSC multiplier	-	-	-	GSCMUL[4:0]				
0x15	GSCDIV	GSC divider	-	-	-	-	GSCDIV[3:0]			
0x16	GSCMAX	Max oscillator cycles between GSC pulses	GSCMAX[7:0]							
0x17			GSCMAX[15:8]							
0x18	PHICTRL	PHI processing control	-	-	-	-	-	PHIMINEN	-	-
0x19	PHIGEN	PHI clock generator	PHIGEN[7:0]							
0x1A			PHIGEN[15:8]							
0x1B		UNUSED	UNUSED							
0x1C	PHIMIN	Min GSC pulses over PHI period	PHIMIN[7:0]							
0x1D			PHIMIN[11:8]							
0x1E	PWMCTRL	PWM control	FLDBKEN	-	GINTEN	PWM-OFLOWEN	PWMGLBLEN	PHADLYEN	PWM-DIRECT	PWMEN
0x1F	GINT	Global PWM scaling	GINT[7:0]							



ADDRESS AND REGISTER NAME		FUNCTION	REGISTER DATA							
			D7	D6	D5	D4	D3	D2	D1	D0
0x20	STR0SET	Phase delay and EO assignment for string 0	PHDLY0[7:0]							
0x21			COLSTR0[1:0]	-	-	PHDLY[11:8]				
↓	↓	↓	↓							
0x3E	STR15SET	Phase delay and EO assignment for string 15	PHDLY15[7:0]							
0x3F			COLSTR15[1:0]	-	-	PHDLY[11:8]				
0x40	PWM0	12-bit PWM setting for string 0	PWM0[7:0]							
0x41			-	-	-	-	PWM0[11:8]			
↓	↓	↓	↓							
0x5E	PWM15	12-bit PWM setting for string 15	PWM15[7:0]							
0x5F			-	-	-	-	PWM15[11:8]			
- DO NOT ACCESS ADDRESS RANGE 0X60 THRU 0X8F -										
0x90	E2ADDR	EEPROM read/write access	-	E2ADDR[6:0]						
0x91	E2CTRLSTA		E2BUSY	BLDACT	E2ERR	-	-	RWCTRL[2:0]		
0x93	FBOSTATUS	FBO status	-	-	FBOOPEN	-	-	FBOACTIVE	FBOCAL	FBOINITCAL

## Register Power-up Defaults

Register power-up default values are shown in Table 3.

**Table 3. Atmel LED Drivers-MSL3167/8 Register Power-up Defaults**

REGISTER NAME AND ADDRESS		POWER-UP CONDITION	REGISTER DATA								
			HEX	D7	D6	D5	D4	D3	D2	D1	D0
<b>REGISTERS INITIALIZED FROM E<sup>2</sup>PROM</b>											
0x00	CONTROL0	LED strings STR0 thru STR7 enabled	FF	1	1	1	1	1	1	1	1
0x01	CONTROL1	LED strings STR8 thru STR15 enabled	FF	1	1	1	1	1	1	1	1
0x02	POWERCTRL	Efficiency Optimizer output enabled FBO open circuit detection disabled String open circuit detection enabled LED short circuit detection enabled GSC maximum fault detection disabled PHI minimum fault detection disabled I <sup>2</sup> C bus timeout detection enabled Device awake	4D	0	1	0	0	1	1	0	1
0x08	FLTMASK0	Fault detection enabled on all strings	FF	1	1	1	1	1	1	1	1
0x09	FLTMASK1		FF	1	1	1	1	1	1	1	1

# Atmel LED Drivers-MSL3 167/MSL3 168

16-string, White LED Drivers with Adaptive Power Control,  
Simple PWM Dimming Interface, and Fault Handling

REGISTER NAME AND ADDRESS		POWER-UP CONDITION	REGISTER DATA								
			HEX	D7	D6	D5	D4	D3	D2	D1	D0
0x0A	FBOCTRL0	Current sink error confirmation delay = 4 $\mu$ S FBO power supply correction delay = 1ms Efficiency Optimizer recalibration delay = 1s Efficiency Optimizer correction steps = 3	44	0	1	0	0	0	1	0	0
0x0B	FBOCTRL1	Current sink error detection not disabled Auto recalibration enabled Auto recalibration does not force strings to 100% duty cycle Initial calibration does not force strings to 100% duty cycle Efficiency Optimizer operates using 1 $\mu$ A steps LED short circuit confirmation delay = 4 $\mu$ s	4A	0	0	0	1	1	0	1	0
0x0F	ISTR	Strings current set to 50% of R <sub>ILED</sub> setting	7F	0	1	1	1	1	1	1	1
0x10	OSCCTRL	f <sub>OSC</sub> = 20MHz	04	0	0	0	0	0	1	0	0
0x11	GSCCTRL	Although disabled, GSC max monitors pGSC	01	0	0	0	0	0	0	0	1
0x12	GSCGEN	Internal GSC frequency = 20MHz / (19 + 1) = 1MHz	23	0	0	0	1	0	0	1	1
0x13			00	0	0	0	0	0	0	0	0
0x14	GSCMUL	GSC multiplied by 4	03	0	0	0	0	0	0	1	1
0x15	GSCDIV	GSC not divided	00	0	0	0	0	0	0	0	0
0x16	GSCMAX	Although disabled, GSC max count is set to 19 clock cycles	13	0	0	0	1	0	0	1	1
0x17			00	0	0	0	0	0	0	0	0
0x18	PHICTRL	PHI minimum pulse count detect is disabled	01	0	0	0	0	0	0	0	1
0x19	PHIGEN	Internal PHI frequency = 20MHz / (8 * (10416 + 1)) = 240Hz	B0	1	0	1	1	0	0	0	0
0x1A			28	0	0	1	0	1	0	0	0
0x1C	PHIMIN	Although PHI min check is disabled, PHI min = 0	00	0	0	0	0	0	0	0	0
0x1D			00	0	0	0	0	0	0	0	0
0x1E	PWMCTRL	PWM operation enabled External signal at PWM Determines t <sub>ON</sub> and t <sub>OFF</sub> Phase delay enabled PWM input not used as gate for PWM engine output String on times allowed to extend beyond PWM frame GINT ignored String short circuit fault current foldback enabled	97	1	0	0	1	0	1	1	1
0x1F	GINT	Although disabled, global intensity is set to (127 + 1) / 255 = 50.2%	7F	0	1	1	1	1	1	1	1
0x20	STR0SET	All strings set to zero phase delay	00	0	0	0	0	0	0	0	0
0x21			40	0	1	0	0	0	0	0	0
↓	↓										
0x3E	STR15SET		00	0	0	0	0	0	0	0	0
0x3F			40	0	1	0	0	0	0	0	0



REGISTER NAME AND ADDRESS		POWER-UP CONDITION	REGISTER DATA								
			HEX	D7	D6	D5	D4	D3	D2	D1	D0
0x40	PWM0	Although disabled, all strings have PWM value = 512 GSC cycles	00	0	0	0	0	0	0	0	0
0x41			02	0	0	0	0	0	0	1	0
↓	↓		↓								
0x5E	PWM15		00	0	0	0	0	0	0	0	0
0x5F			02	0	0	0	0	0	0	1	0
REGISTERS WITH FIXED INITIAL VALUES											
0x90	E2ADDR	EEPROM 7-bit address = 0x00	00	0	0	0	0	0	0	0	0
0x91	E2CTRLSTA	EEPROM read/write disabled	00	0	0	0	0	0	0	0	0
0x93	FBOSTATUS	Feedback output status	00	0	0	0	0	0	0	0	0

**Atmel Corporation**

2325 Orchard Parkway  
 San Jose, CA 95131  
 USA  
**Tel:** (+1)(408) 441-0311  
**Fax:** (+1)(408) 487-2600  
 www.atmel.com

**Atmel Asia Limited**

Unit 01-5 & 16, 19F  
 BEA Tower, Millennium City 5  
 418 Kwun Tong Road  
 Kwun Tong, Kowloon  
 HONG KONG  
**Tel:** (+852) 2245-6100  
**Fax:** (+852) 2722-1369

**Atmel Munich GmbH**

Business Campus  
 Parkring 4  
 D-85748 Garching b. Munich  
 GERMANY  
**Tel:** (+49) 89-31970-0  
**Fax:** (+49) 89-3194621

**Atmel Japan**

9F, Tonetsu Shinkawa Bldg.  
 1-24-8 Shinkawa  
 Chuo-ku, Tokyo 104-0033  
 JAPAN  
**Tel:** (+81)(3) 3523-3551  
**Fax:** (+81)(3) 3523-7581