

Data Sheet

LL01CR-AYMxxR35-P



CXA25xx



■ Features & Typical Applications

- High efficiency
- Available with 3 beam angles
- Optimized Uniformity
- Reflectors with Holder
- Spotlight
- Highbay
- Downlight

■ Table of Contents

General Information & Product Nomenclature.....	P.2
Optical Specifications	P.3
Mechanical Specifications.....	P.4
Package Specifications.....	P.5

LL01CR-AYMxxR35-P

General Information

- Reflector Material : PC LEV1700.
- Plastic reflector metalized aluminum.
- Operating Temperature range -40°C~+110°C(upper limit +120°C).
- Storage Temperature range -40°C~+110°C(upper limit +120°C).
 * Average transmittance in visible spectrum 400nm~700nm>90%.
- Usage and Maintenance:
 1. If necessary, clean lenses with mild soap, water and soft cloth.
 2. Never use any commercial cleaning solvents on lenses, like alcohol.
 3. Please handle or install lenses with wearing gloves, skin oils may damage lens or its optical characteristic.

Product Nomenclature

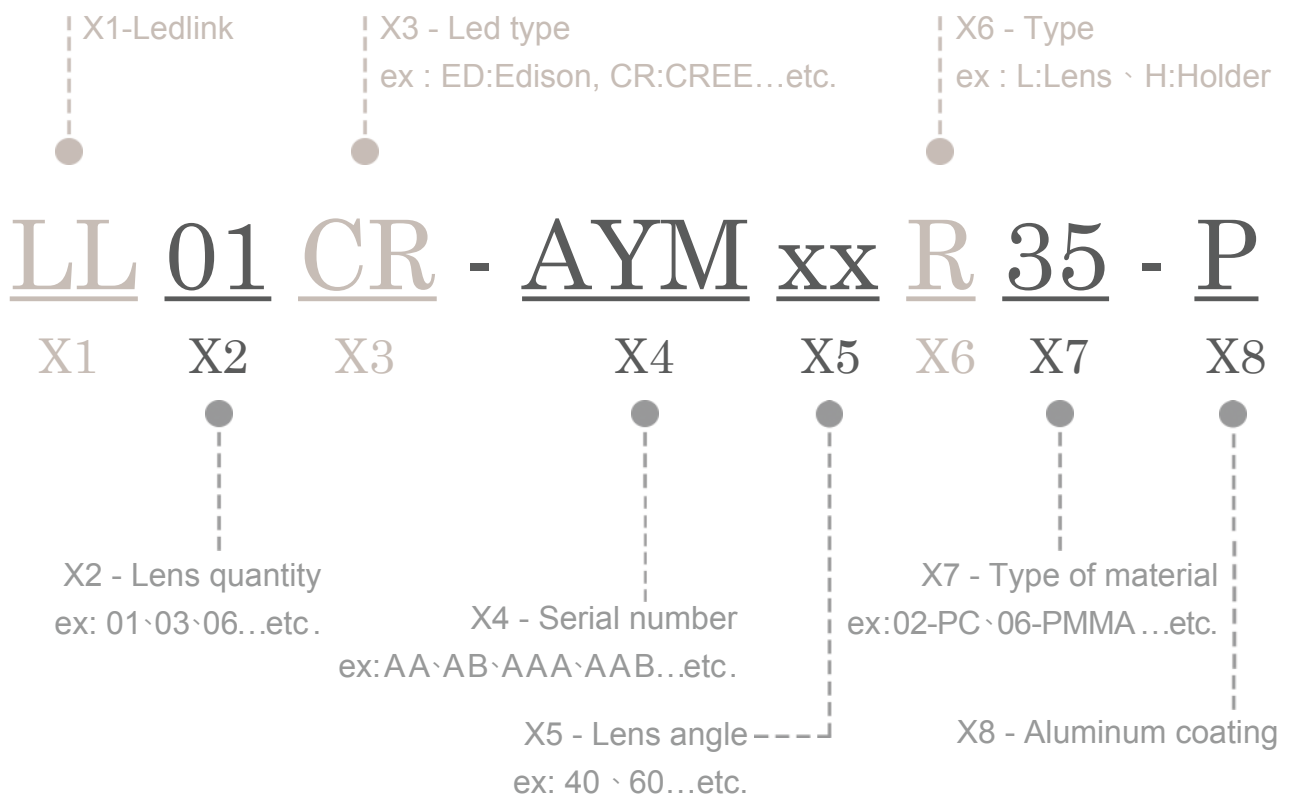

LL01CR-AYMxxR35-P

Optical Specifications

CXA2520

Note: (1) All the results of analysis are based on 0 degrees of elevation.
 (2) Tolerance: $\pm 10\%$.
 (3) Led Luminous Flux(lm): 2499($\pm 5\%$).

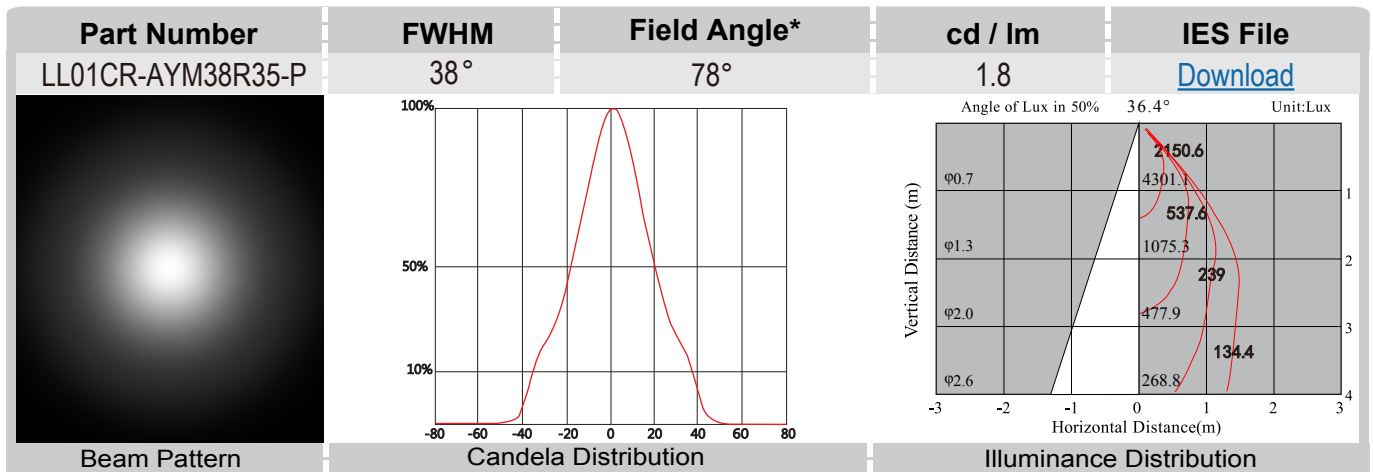
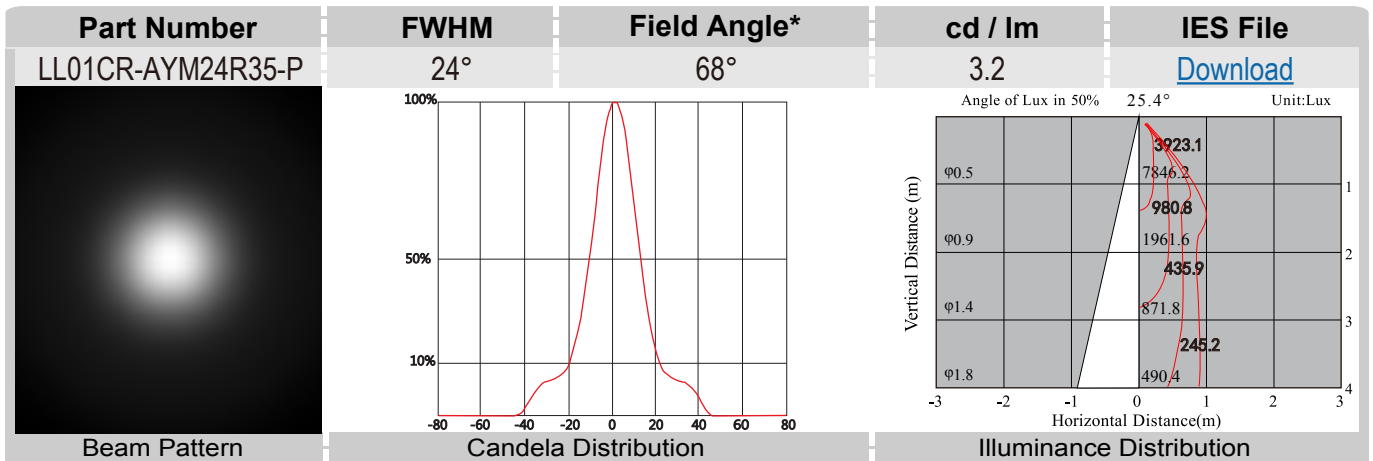
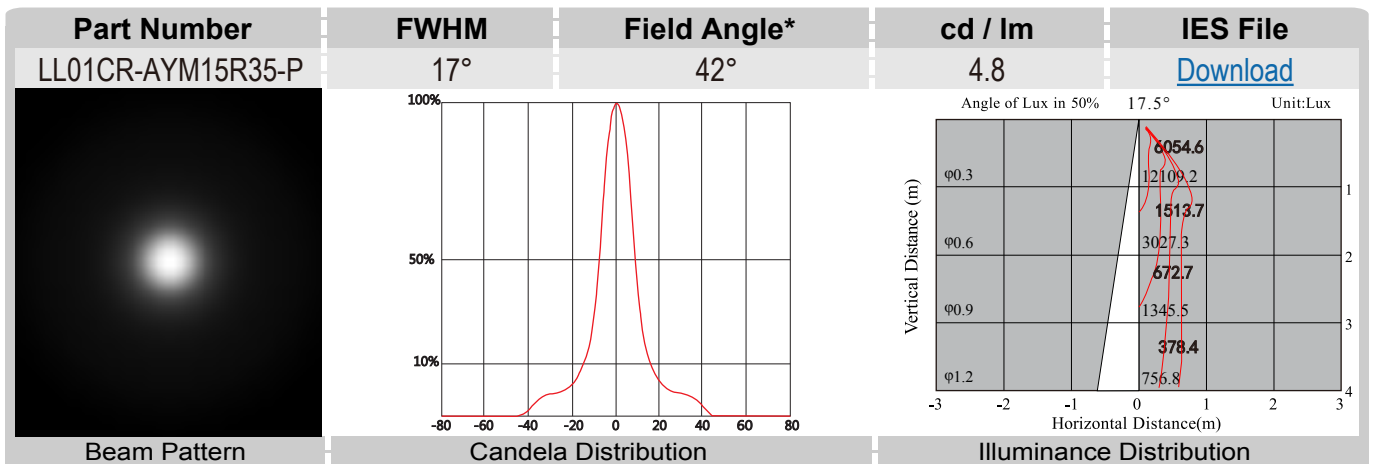

*The Field Angle is the angle between the two directions opposed to each other over the beam axis for which the luminous intensity is 10% that of the maximum luminous intensity.
 *This testing result is obtained through testing the popular rank LED samples which provided by the original manufacturer. Hence, the testing results would be varied as the users choose same LED model but different rank.

LL01CR-AYMxxR35-P

Mechanical Specification

1. Fixing method

- Glue
 Screw
 Tape
 Fixing-ring
 Frame

Note: (1) All dimensions are in mm.
 (2) All tolerance are ± 0.15 mm unless otherwise specified.

2. Reflector dimension

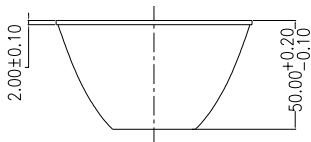
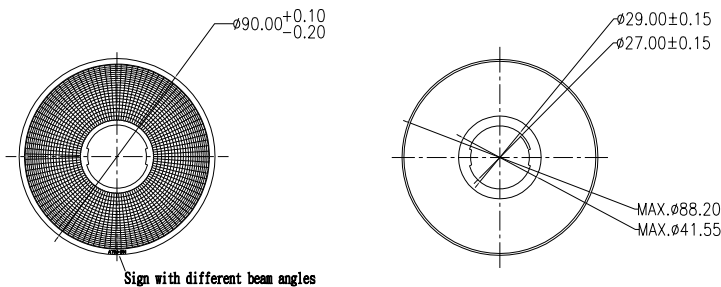

3. Reflector + Connector + Leds assembly instruction



4. Connector dimension

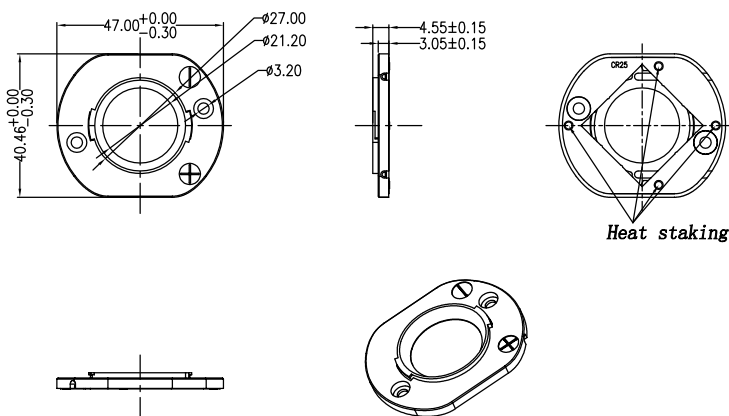

5. View assembly Reflector with LED:

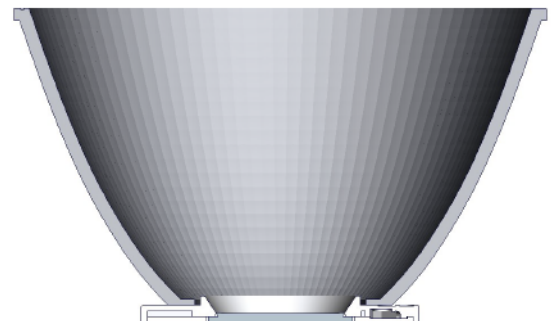

LL38A00SUUB2-M2