

REVISIONS				
REV. SYM.	E.C.D. NUMBER	DESCRIPTION	BY DATE	APP'D DATE
1		ORIGINAL RELEASE	JMC 4-10-00	JWJ 4-10-00

**UNCONTROLLED DOCUMENT
WILL NOT BE UPDATED**

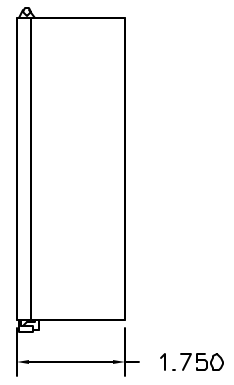
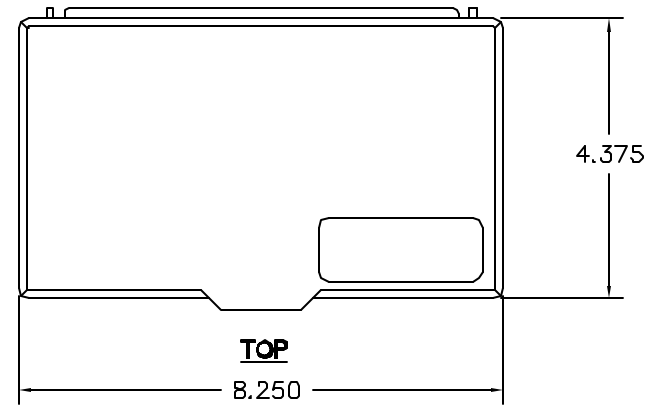

INSPECTION INSTRUCTIONS

"TO-UP" GAUGE
 Operate tool in the fully closed position. Maintain firm hand pressure on the tool handle. Insert the "TO-UP" plug into the gauge. The gauge must pass freely through the opening.

"TO-DOWN" GAUGE
 Operate tool in the fully closed position. Maintain firm hand pressure on the tool handle. Insert the "TO-DOWN" plug into the gauge. The gauge must pass completely through the opening.

CAUTION: Do not crimp gauge.

RELATION	GAUGE	PLUG	PLUG NO.
1	G213	G219	G223
2	G214	G219	G223
3	G215	G219	G223
4	G216	G219	G223
5	G213	G218	G217
6	G214	G218	G217
7	G215	G218	G217
8	G216	G218	G217

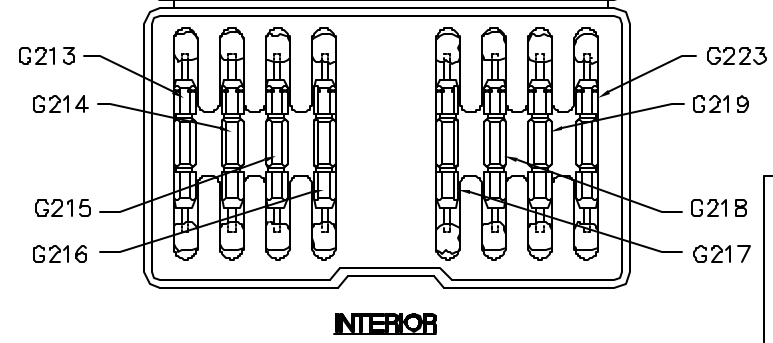

RESTRICTED & CONFIDENTIAL CONFIDENTIAL PROPERTY OF DANIELS MANUFACTURING CORP. NOT TO BE DISCLOSED TO OTHERS. REPRODUCED OR USED FOR ANY OTHER PURPOSE, EXCEPT AS AUTHORIZED IN WRITING BY DANIELS MANUFACTURING. MUST BE RETURNED TO DANIELS MANUFACTURING CORP. ON COMPLETION OF ORDER OR OTHER PURPOSE FOR WHICH LENT.	MATERIAL	ITEM	PART NO.	QTY.	DESCRIPTION/REMARKS	
	HEAT TREAT	DRN	JMC	DATE 4-10-00	DMC DANIELS MANUFACTURING CORP. ORLANDO, FLORIDA CAGE 11857	
		CHK'D.	JWJ	DATE 4-10-00		
	FINISH	APP'D.		DATE	TITLE INSPECTION GAGE SET ENVELOPE DRAWING	
APP'D.			DATE			
DO NOT SCALE DRAWING	WHERE USED:		SIZE	SCALE	CAD P/N	SHEET OF
			B	NTS	88-200-ENV	1 1
			POSTING	P/N	88-200-ENV	REV.