

REVISIONS				
REV. SYM.	E.C.D. NUMBER	DESCRIPTION	BY DATE	APP'D DATE
1		ORIGINAL RELEASE	JMC 4-10-00	JWJ 4-10-00

**UNCONTROLLED DOCUMENT
WILL NOT BE UPDATED**

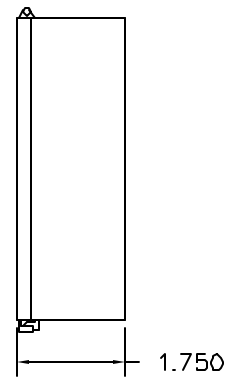
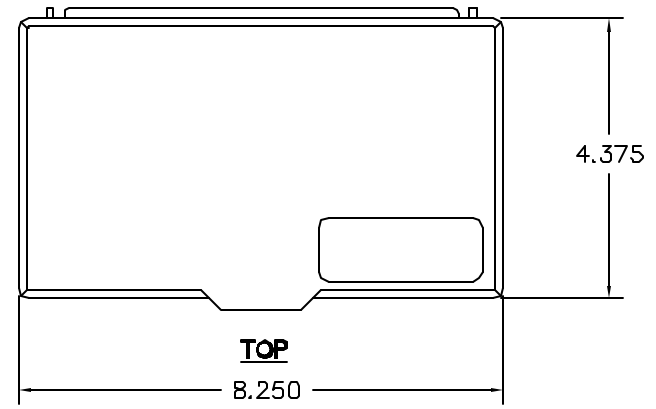

INSPECTION INSTRUCTIONS

"TO" GAUGE
 Square lead to the fully closed position. Maintain the normal pressure on the lead handle. Insert "TO" gauge and slip. The gauge must pass freely through the opening.

"TO-OF" GAUGE
 Square lead to the fully closed position. Maintain the hand pressure on the lead handle. Insert the "TO-OF" gauge and slip. The "TO-OF" gauge may enter the indicator opening, but must not pass completely through the opening.

CAUTION: Do not crimp gauge.

RELATION	A	B	C	D	E	F	G	H	I	J	K	L	M	N	O	P	Q	R	S	T	U	V	W	X	Y	Z	
1																											
2																											
3																											
4																											
5																											
6																											
7																											
8																											

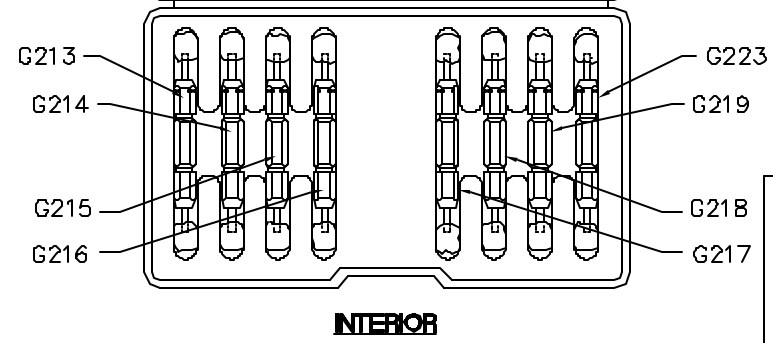

RESTRICTED & CONFIDENTIAL CONFIDENTIAL PROPERTY OF DANIELS MANUFACTURING CORP. NOT TO BE DISCLOSED TO OTHERS. REPRODUCED OR USED FOR ANY OTHER PURPOSE, EXCEPT AS AUTHORIZED IN WRITING BY DANIELS MANUFACTURING. MUST BE RETURNED TO DANIELS MANUFACTURING CORP. ON COMPLETION OF ORDER OR OTHER PURPOSE FOR WHICH LENT.	MATERIAL	ITEM	PART NO.	QTY.	DESCRIPTION/REMARKS		
	HEAT TREAT	DRN	JMC	DATE 4-10-00	DMC DANIELS MANUFACTURING CORP. ORLANDO, FLORIDA CAGE 11857		
		CHK'D.	JWJ	DATE 4-10-00			
	FINISH	APP'D.		DATE	TITLE INSPECTION GAGE SET ENVELOPE DRAWING		
APP'D.			DATE				
DO NOT SCALE DRAWING	WHERE USED:		SIZE	SCALE	CAD P/N	SHEET	OF
			B	NTS	88-200-ENV	1	1
			POSTING	P/N	88-200-ENV	REV.	1