

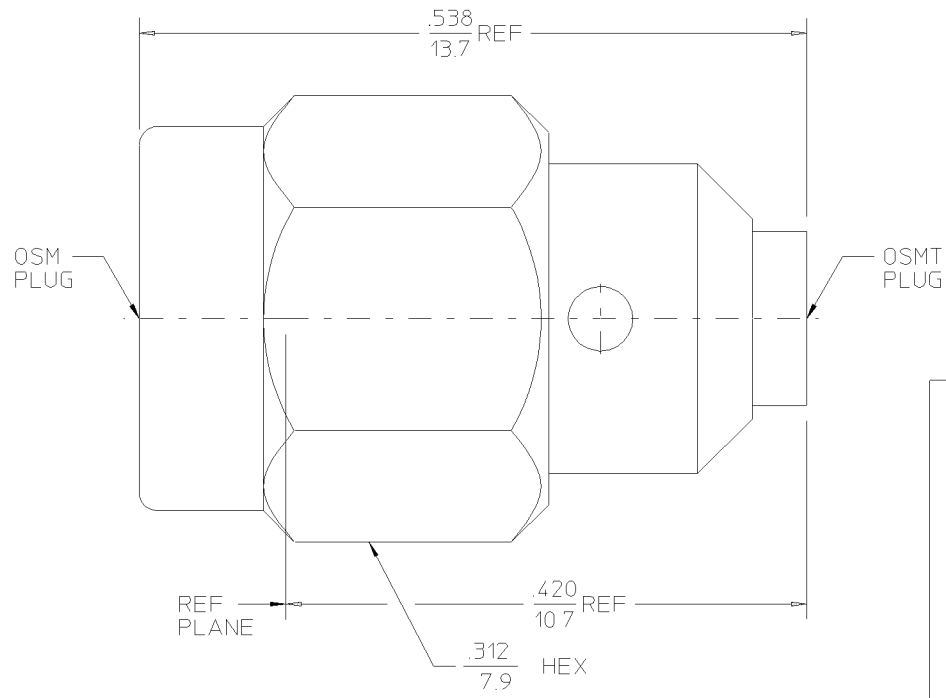

REVISIONS			
REV	DESCRIPTION	DATE	APPROVED
03 <sub>0</sub>	REVISED	10/27/96	TCom 10/22/96



1055695-1  
PART NUMBER

COMPONENT	MATERIAL	FINISH
COUPLING NUT	STAINLESS STEEL PER ASTM-A484 AND ASTM-A582, TYPE 303	GOLD PLATE PER MIL-G-45204
HOUSING	BRASS PER ASTM-B-16 HALF HARD	GOLD PLATE PER MIL-G-45204
DIELECTRIC	TFE FLUOROCARBON PER ASTM-D-1457	N/A
CENTER CONTACT	BERYLLIUM COPPER PER ASTM B 196 OR ASTM B 197, ALLOY C17300, CONDITION H	GOLD PLATE PER MIL-G-45204
RETAINING RING	BERYLLIUM COPPER PER ASTM B 194, ALLOY C17200, CONDITION H	N/A
GASKET	SILICONE RUBBER PER ZZ-R-765	N/A

NOTES:  
1. CAPTURED CENTER CONTACT

UNLESS OTHERWISE SPECIFIED DIMENSIONS ARE IN INCHES TOLERANCE ON FRAC DEC. ANGLES ± 1/64 ±.005 ± 1°	DRAWN BY: <i>B.W.</i> DATE: 4/17/92	 M/A-COM, Inc. Waltham, MA 02254 <i>an AMP company</i>
	CHECKED BY: <i>M.H.</i> 07/23/92	
These drawings and specifications are the property of M/A-COM incorporated and shall not be reproduced or copied or used in whole or in part as the basis for the manufacture or sale of item(s) without written permission.	APPD BY: <i>J.M.</i> 04/17/92	TITLE OSMT PLUG TO OSM PLUG ADAPTER
	USE ASSY PROCEDURE	NO. AP. N/A
	SCALE 10 : 1	SHEET 1 OF 1