

MARCH 2018

256Kx8 LOW VOLTAGE, ULTRA LOW POWER CMOS STATIC RAM

KEY FEATURES

- High-speed access time: 45ns, 55ns
- CMOS low power operation
 - Operating Current: 26 mA (max) at 125°C
 - CMOS Standby Current: 3.0 uA (typ) at 25°C
- TTL compatible interface levels
- Single power supply
 - 1.65V-2.2V V_{DD} (IS62/65WV2568FALL)
 - 2.2V-3.6V V_{DD} (IS62/65WV2568FBLL)
- Three state outputs
- Industrial and Automotive temperature support
- Lead-free available

DESCRIPTION

The ISSI IS62/65WV2568FALL/BLL are high-speed, 2M bit static RAMs organized as 256K words by 8 bits. It is fabricated using ISSI's high-performance CMOS technology. This highly reliable process coupled with innovative circuit design techniques, yields high-performance and low power consumption devices.

When CS1# is HIGH (deselected) or when CS2 is LOW (deselected), the device assumes a standby mode at which the power dissipation can be reduced down with CMOS input levels.

Easy memory expansion is provided by using Chip Enable and Output Enable inputs. The active LOW Write Enable (WE#) controls both writing and reading of the memory.

The IS62/65WV2568FALL/BLL are packaged in the JEDEC standard 32-pin TSOP (TYPE I), sTSOP (TYPE I), and 36-pin mini BGA.

FUNCTIONAL BLOCK DIAGRAM

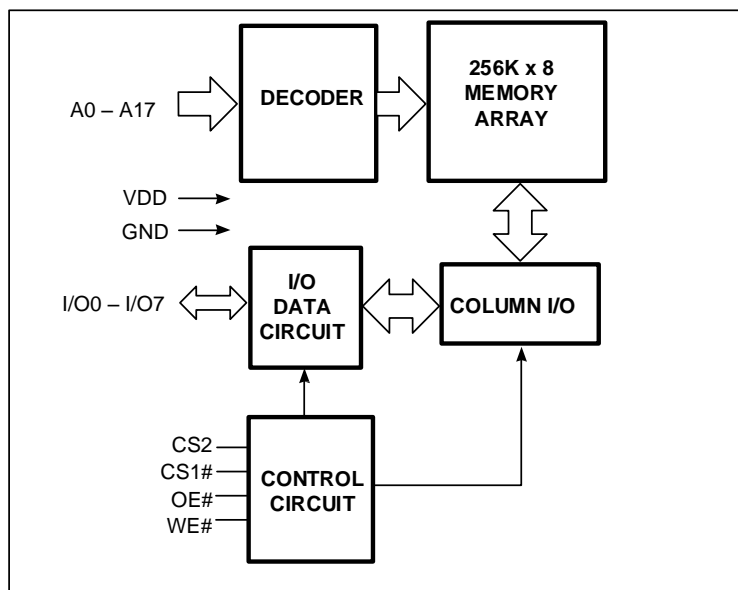

Copyright © 2018 Integrated Silicon Solution, Inc. All rights reserved. ISSI reserves the right to make changes to this specification and its products at any time without notice. ISSI assumes no liability arising out of the application or use of any information, products or services described herein. Customers are advised to obtain the latest version of this device specification before relying on any published information and before placing orders for products.

Integrated Silicon Solution, Inc. does not recommend the use of any of its products in life support applications where the failure or malfunction of the product can reasonably be expected to cause failure of the life support system or to significantly affect its safety or effectiveness. Products are not authorized for use in such applications unless Integrated Silicon Solution, Inc. receives written assurance to its satisfaction, that:

- a.) the risk of injury or damage has been minimized;
- b.) the user assume all such risks; and
- c.) potential liability of Integrated Silicon Solution, Inc is adequately protected under the circumstances

PIN CONFIGURATIONS

36-Pin mini BGA (6mm x 8mm)

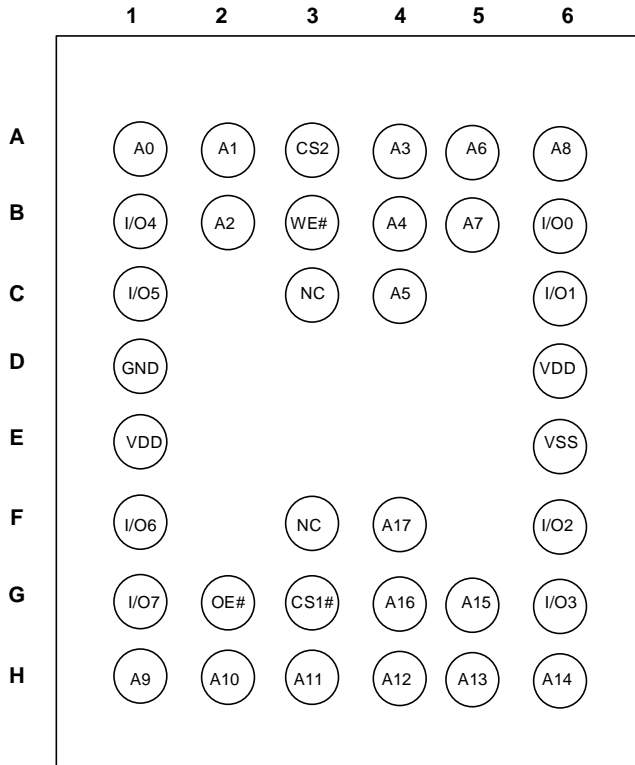

32-Pin TSOP (Type I), STSOP (Type I)

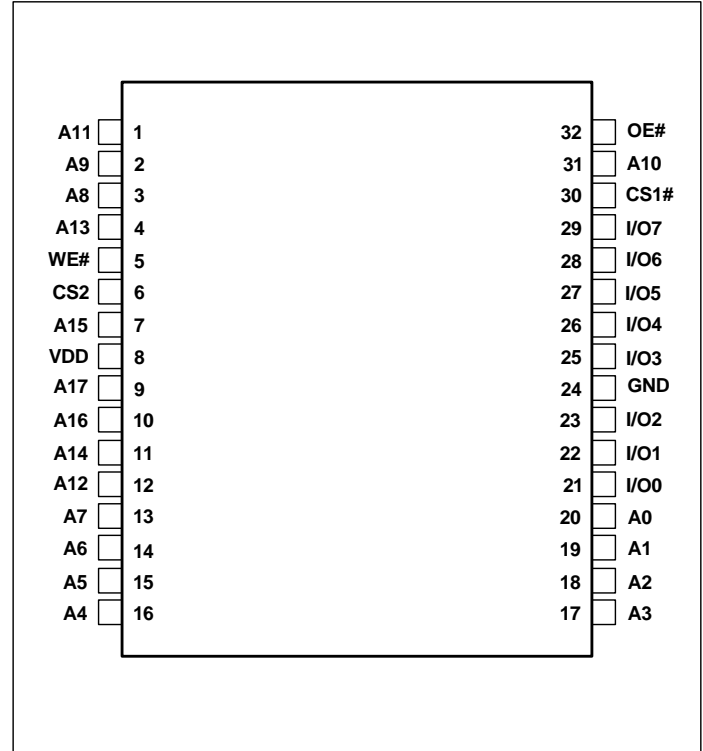

PIN DESCRIPTIONS

A0-A17	Address Inputs
I/O0-I/O7	Data Inputs/Outputs
CS1#, CS2	Chip Enable Input
OE#	Output Enable Input
WE#	Write Enable Input
NC	No Connection
VDD	Power
GND	Ground

FUNCTION DESCRIPTION

SRAM is one of random access memories. SRAM has three different modes supported. Each function is described below with Truth Table.

STANDBY MODE

Device enters standby mode when deselected (CS1# HIGH or CS2 LOW). The input and output pins (I/O0-7) are placed in a high impedance state. CMOS input in this mode will maximize saving power.

WRITE MODE

Write operation issues with Chip selected (CS1# LOW and CS2 HIGH) and Write Enable (WE#) input LOW. The input and output pins (I/O0-7) are in data input mode. Output buffers are closed during this time even if OE# is LOW.

READ MODE

Read operation issues with Chip selected (CS1# LOW and CS2 HIGH) and Write Enable (WE#) input HIGH. When OE# is LOW, output buffer turns on to make data output. Any input to I/O pins during READ mode is not permitted.

In the READ mode, output buffers can be turned off by pulling OE# HIGH. In this mode, internal device operates as READ but I/Os are in a high impedance state. Since device is in READ mode, active current is used.

TRUTH TABLE

Mode	CS1#	CS2	WE#	OE#	I/O0-I/O7	VDD Current
Not Selected	H	X	X	X	High-Z	ISB2
	X	L	X	X	High-Z	
Output Disabled	L	H	H	H	High-Z	ICC
Read	L	H	H	L	D _{OUT}	ICC
Write	L	H	L	X	D _{IN}	ICC

ABSOLUTE MAXIMUM RATINGS AND OPERATING RANGE

ABSOLUTE MAXIMUM RATINGS ⁽¹⁾

Symbol	Parameter	Value	Unit
V _{term}	Terminal Voltage with Respect to GND	-0.2 to +3.9 (V _{DD} +0.3V)	V
tBIAS	Temperature Under Bias	-55 to +125	°C
V _{DD}	V _{DD} Related to GND	-0.2 to +3.9 (V _{DD} +0.3V)	V
tStg	Storage Temperature	-65 to +150	°C
I _{OUT} ⁽²⁾	DC Output Current (LOW)	20	mA

Notes:

Stress greater than those listed under ABSOLUTE MAXIMUM RATINGS may cause permanent damage to the device. This is a stress rating only and functional operation of the device at these or any other conditions above those indicated in the operational sections of this specification is not implied. Exposure to absolute maximum rating conditions for extended periods may affect reliability. This condition is not per pin. Total current of all pins must meet this value.

OPERATING RANGE ⁽¹⁾

Range	Ambient Temperature	Device Marking	V _{DD}
Commercial	0°C to +70°C	IS62WV2568FALL	1.65V-2.2V
Industrial	-40°C to +85°C	IS62WV2568FALL	1.65V-2.2V
Commercial	0°C to +70°C	IS62WV2568FBLL	2.2V-3.6V
Industrial	-40°C to +85°C	IS62WV2568FBLL	2.2V-3.6V
Automotive	-40°C to +125°C	IS65WV2568FBLL	2.2V-3.6V

Note:

1. Full device AC operation assumes a 100 μs ramp time from 0 to V_{CC}(min) and 200 μs wait time after V_{CC} stabilization.

PIN CAPACITANCE ⁽¹⁾

Parameter	Symbol	Test Condition	Max	Units
Input capacitance	C _{IN}	T _A = 25°C, f = 1 MHz, V _{DD} = V _{DD} (typ)	10	pF
DQ capacitance (IO0–IO7)	C _{I/O}		10	pF

Note:

1. These parameters are guaranteed by design and tested by a sample basis only.

THERMAL CHARACTERISTICS ⁽¹⁾

Parameter	Symbol	Rating	Units
Thermal resistance from junction to ambient (airflow = 1m/s)	R _{θJA}	TBD	°C/W
Thermal resistance from junction to pins	R _{θJB}	TBD	°C/W
Thermal resistance from junction to case	R _{θJC}	TBD	°C/W

Note:

1. These parameters are guaranteed by design and tested by a sample basis only.

ELECTRICAL CHARACTERISTICS

IS62WV2568FALL DC ELECTRICAL CHARACTERISTICS-I (OVER THE OPERATING RANGE)

VDD=1.65V~2.2V

Symbol	Parameter	Test Conditions	Min.	Max.	Unit
V _{OH}	Output HIGH Voltage	I _{OH} = -0.1 mA	1.4	—	V
V _{OL}	Output LOW Voltage	I _{OL} = 0.1 mA	—	0.2	V
V _{IH} ⁽¹⁾	Input HIGH Voltage		1.4	V _{DD} + 0.2	V
V _{IL} ⁽¹⁾	Input LOW Voltage		-0.2	0.4	V
I _{LI}	Input Leakage	GND < V _{IN} < V _{DD}	-1	1	μA
I _{LO}	Output Leakage	GND < V _{IN} < V _{DD} , Output Disabled	-1	1	μA

Notes:

- V_{ILL}(min) = -1.0V AC (pulse width < 10ns). Not 100% tested.
V_{IHH} (max) = V_{DD} + 1.0V AC (pulse width < 10ns). Not 100% tested.

IS62 (5) WV2568FBLL DC ELECTRICAL CHARACTERISTICS-I (OVER THE OPERATING RANGE)

VDD=2.2V~3.6V

Symbol	Parameter	Test Conditions	Min.	Max.	Unit
V _{OH}	Output HIGH Voltage	2.2 ≤ V _{DD} < 2.7, I _{OH} = -0.1 mA	2.0	—	V
		2.7 ≤ V _{DD} ≤ 3.6, I _{OH} = -1.0 mA	2.4	—	V
V _{OL}	Output LOW Voltage	2.2 ≤ V _{DD} < 2.7, I _{OL} = 0.1 mA	—	0.4	V
		2.7 ≤ V _{DD} ≤ 3.6, I _{OL} = 2.1 mA	—	0.4	V
V _{IH} ⁽¹⁾	Input HIGH Voltage	2.2 ≤ V _{DD} < 2.7	1.8	V _{DD} + 0.3	V
		2.7 ≤ V _{DD} ≤ 3.6	2.2	V _{DD} + 0.3	V
V _{IL} ⁽¹⁾	Input LOW Voltage	2.2 ≤ V _{DD} < 2.7	-0.3	0.6	V
		2.7 ≤ V _{DD} ≤ 3.6	-0.3	0.8	V
I _{LI}	Input Leakage	GND < V _{IN} < V _{DD}	-1	1	μA
I _{LO}	Output Leakage	GND < V _{IN} < V _{DD} , Output Disabled	-1	1	μA

Notes:

- V_{ILL}(min) = -2.0V AC (pulse width < 10ns). Not 100% tested.
V_{IHH} (max) = V_{DD} + 2.0V AC (pulse width < 10ns). Not 100% tested.

IS62WV2568FALL DC ELECTRICAL CHARACTERISTICS-II FOR POWER
(OVER THE OPERATING RANGE)

Symbol	Parameter	Test Conditions	Grade	Typ ⁽¹⁾	Max	Unit	
ICC	V _{DD} Dynamic Operating Supply Current	V _{DD} = V _{DD(max)} , I _{OUT} = 0mA, f = f _{max} CS1# = V _{IL} , CS2 = V _{IH}	Com.	-	26	mA	
			Ind.		26		
ICC1	V _{DD} Static Operating Supply Current	V _{DD} = V _{DD(max)} , I _{OUT} = 0mA, f = 0 CS1# = V _{IL} , CS2 = V _{IH}	Com.	-	5	mA	
			Ind.		5		
ISB2	CMOS Standby Current (CMOS Inputs)	V _{DD} = V _{DD(max)} , f = 0, CS1# ≥ V _{DD} - 0.2V or CS2 ≤ 0.2V, VIN ≤ 0.2V or CS2 ≥ V _{DD} - 0.2V	Com.	25°C	3.0	-	µA
				45°C	3.5	-	
				70°C	4.0	5	
			Ind.	85°C	4.1	6	

Note:
 1. Typical values are measured at V_{DD} = 1.8V, and not 100% tested.

IS62(5)WV2568FBLL DC ELECTRICAL CHARACTERISTICS-II FOR POWER
(OVER THE OPERATING RANGE)

Symbol	Parameter	Test Conditions	Grade	Typ ⁽¹⁾	Max	Unit	
ICC	V _{DD} Dynamic Operating Supply Current	V _{DD} = V _{DD(max)} , I _{OUT} = 0mA, f = f _{max} CS1# = V _{IL} , CS2 = V _{IH}	Com.	-	26	mA	
			Ind.		26		
			Auto.		26		
ICC1	V _{DD} Static Operating Supply Current	V _{DD} = V _{DD(max)} , I _{OUT} = 0mA, f = 0 CS1# = V _{IL} , CS2 = V _{IH}	Com.	-	5	mA	
			Ind.		5		
			Auto.		5		
ISB2	CMOS Standby Current (CMOS Inputs)	V _{DD} = V _{DD(max)} , f = 0, CS1# ≥ V _{DD} - 0.2V or CS2 ≤ 0.2V, VIN ≤ 0.2V or CS2 ≥ V _{DD} - 0.2V	Com.	25°C	3.0	-	µA
				45°C	3.5	-	
				70°C	4.0	5	
			Ind.	85°C	4.1	6	
			Auto.	125°C	9.0	18	

Note:
 1. Typical values are measured at V_{DD} = 3.0V, and not 100% tested.

AC CHARACTERISTICS ⁽⁶⁾ (OVER OPERATING RANGE)

READ CYCLE AC CHARACTERISTICS

Parameter	Symbol	45ns		55ns		unit	notes
		Min	Max	Min	Max		
Read Cycle Time	tRC	45	-	55	-	ns	1,5
Address Access Time	tAA	-	45	-	55	ns	1
Output Hold Time	tOHA	10	-	10	-	ns	1
CS1#, CS2 Access Time	tACS1/ACS2	-	45	-	55	ns	1
OE# Access Time	tDOE	-	20	-	25	ns	1
OE# to High-Z Output	tHZOE	-	18	-	20	ns	2
OE# to Low-Z Output	tLZOE	5	-	5	-	ns	2
CS1#, CS2 to High-Z Output	tHZCS1/HZCS2	-	18	-	20	ns	2
CS1#, CS2 to Low-Z Output	tLZCS/LZCS2	10	-	10	-	ns	2

WRITE CYCLE AC CHARACTERISTICS

Parameter	Symbol	45ns		55ns		unit	notes
		Min	Max	Min	Max		
Write Cycle Time	tWC	45	-	55	-	ns	1,3,5
CS1#, CS2 to Write End	tSCS1/tSCS2	35	-	40	-	ns	1,3
Address Setup Time to Write End	tAW	35	-	40	-	ns	1,3
Address Hold from Write End	tHA	0	-	0	-	ns	1,3
Address Setup Time	tSA	0	-	0	-	ns	1,3
WE# Pulse Width	tPWE	35	-	40	-	ns	1,3,4
Data Setup to Write End	tSD	25	-	25	-	ns	1,3
Data Hold from Write End	tHD	0	-	0	-	ns	1,3
WE# LOW to High-Z Output	tHZWE	-	18	-	20	ns	2,3
WE# HIGH to Low-Z Output	tLZWE	10	-	10	-	ns	2,3

Notes:

1. Tested with the load in Figure 1.
2. Tested with the load in Figure 2. Transition is measured ± 500 mV from steady-state voltage. tHZOE, tHZCS, tHZB, and tHZWE transitions are measured when the output enters a high impedance state. Not 100% tested.
3. The internal write time is defined by the overlap of CS1# = LOW, CS2=HIGH, and WE# = LOW. All four conditions must be in valid states to initiate a Write, but any condition can go inactive to terminate the Write. The Data Input Setup and Hold timing are referenced to the rising or falling edge of the signal that terminates the write.
4. tPWE > tHZWE + tSD when OE# is LOW.
5. Address inputs must meet V_{IH} and V_{IL} SPEC during this period. Any glitch or unknown inputs are not permitted. Unknown input with standby mode is acceptable.
6. Data retention characteristics are defined later in DATA RETENTION CHARACTERISTICS.

AC TEST CONDITIONS (OVER THE OPERATING RANGE)

Parameter	Unit (1.65V~2.2V)	Unit (2.2V~3.6V)
Input Pulse Level	0V to V_{DD}	0V to V_{DD}
Input Rise and Fall Time	1V/ns	1V/ns
Output Timing Reference Level	0.9V	$\frac{1}{2} V_{DD}$
R1	13500	1005
R2	10800	820
V_{TM}	1.8V	V_{DD}
Output Load Conditions	Refer to Figure 1 and 2	

OUTPUT LOAD CONDITIONS FIGURES

Figure1

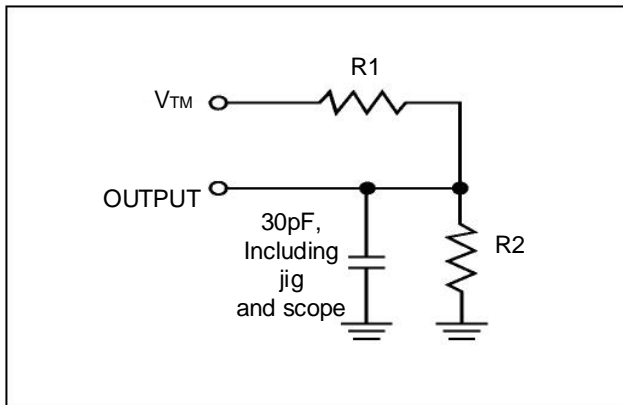
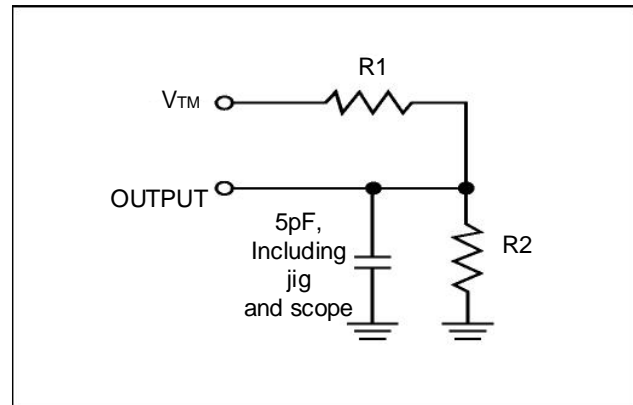
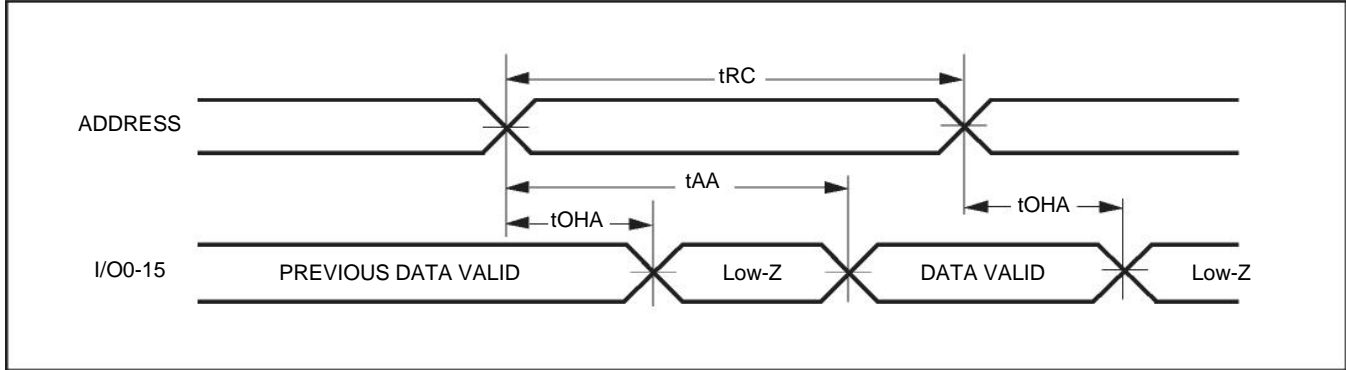

Figure2



TIMING DIAGRAM

READ CYCLE NO. 1⁽¹⁾ (ADDRESS CONTROLLED) (CS1# = OE# = LOW, CS2 = WE# = HIGH)



Notes:

1. The device is continuously selected.

READ CYCLE NO. 2⁽¹⁾ (OE# CONTROLLED)

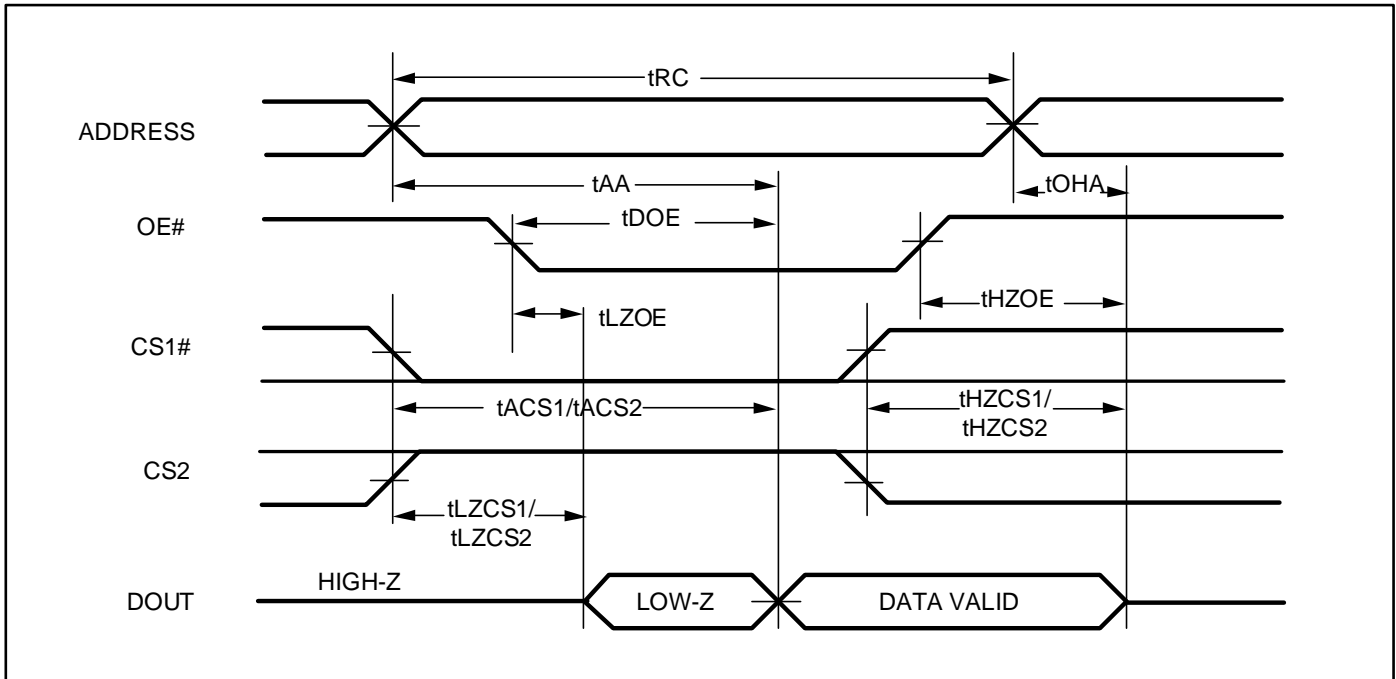

Notes:

1. Address is valid prior to or coincident with CS1# LOW and CS2 HIGH transition.

WRITE CYCLE 1^(1,2) (CS1#, CS2 Controlled, OE# = HIGH or LOW)

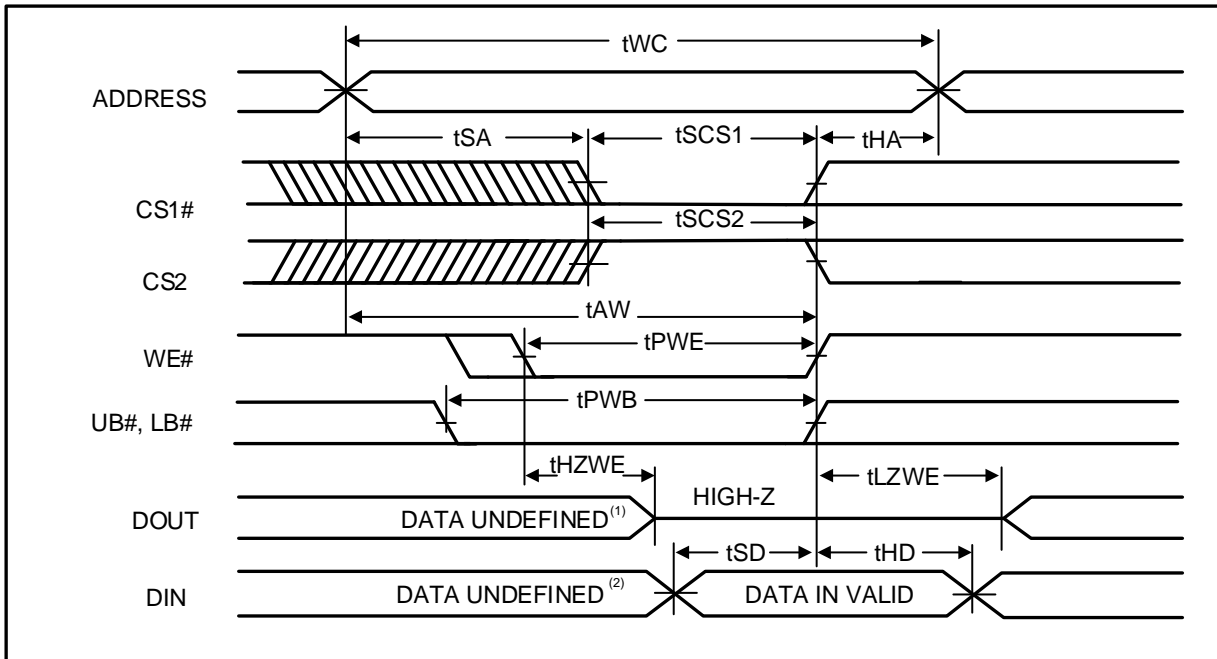

Notes:

1. tHZWE is based on the assumption when tSA=0nS after READ operation. Actual DOUT for tHZWE may not appear if OE# goes high before Write Cycle. tHZOE is the time DOUT goes to High-Z after OE# goes high
2. During this period the I/Os are in output state. Do not apply input signals.

WRITE CYCLE NO. 2^(1,2) (WE# Controlled: OE# is HIGH During Write Cycle)

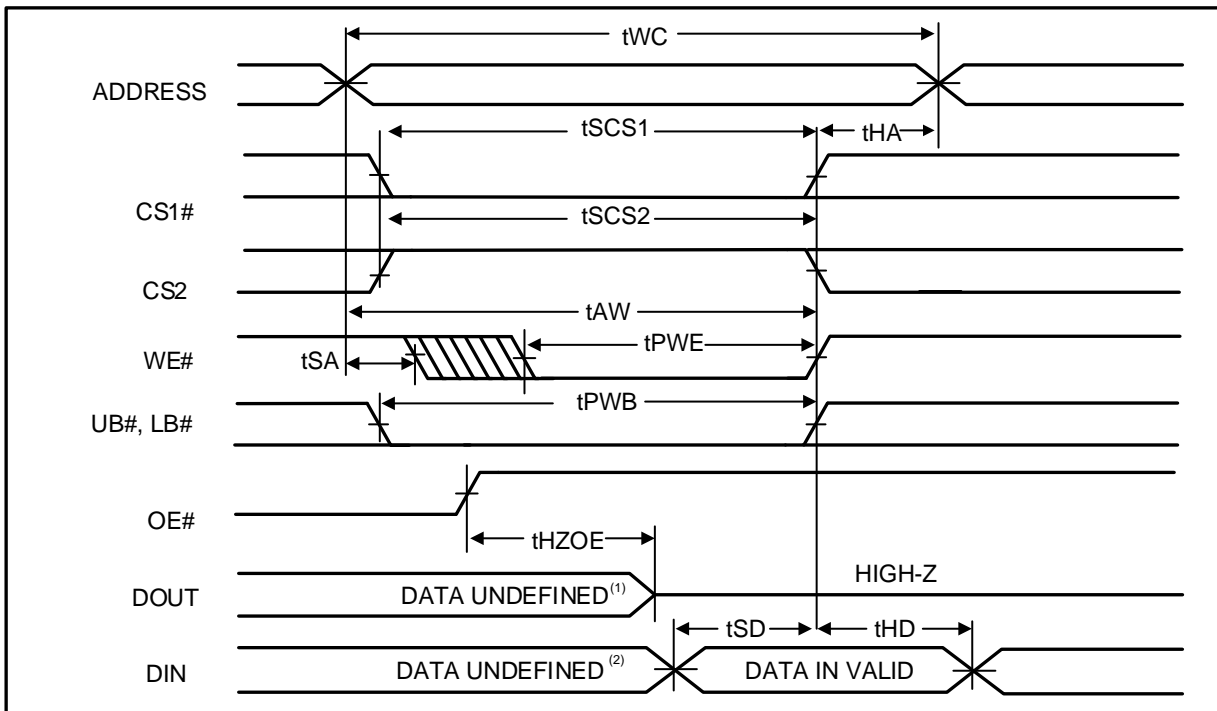

Notes:

1. tHZOE is the time DOUT goes to High-Z after OE# goes high.
2. During this period the I/Os are in output state. Do not apply input signals.

WRITE CYCLE NO. 3⁽¹⁾ (WE# CONTROLLED: OE# IS LOW DURING WRITE CYCLE)

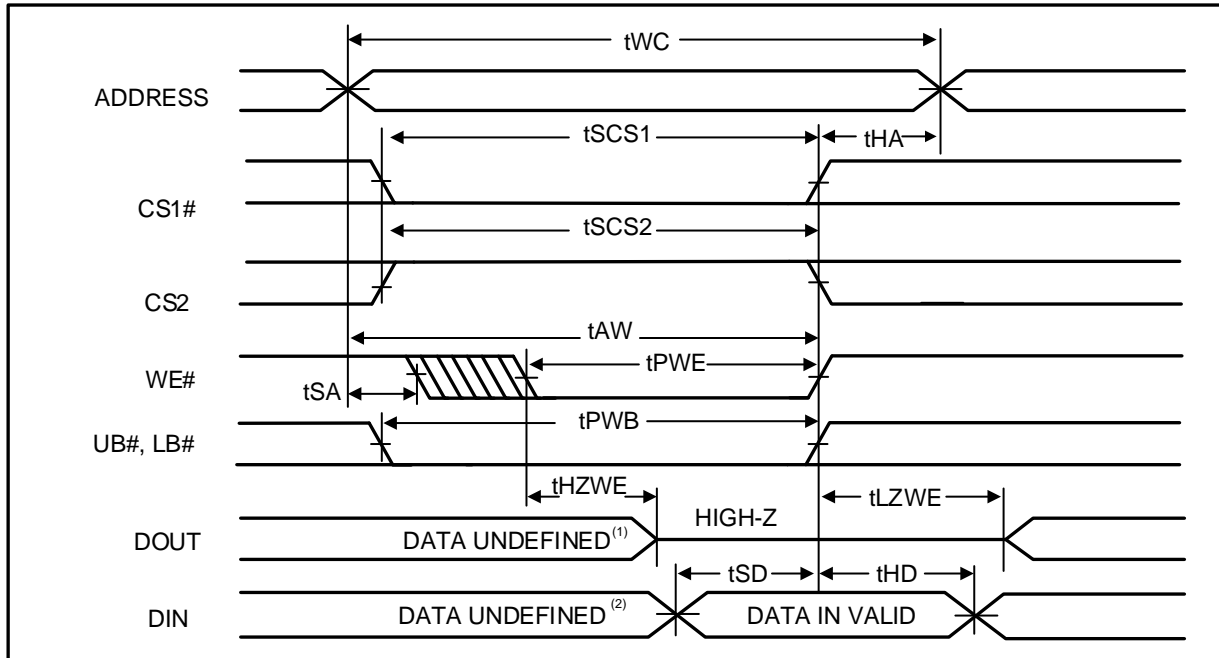

Note:

1. If OE# is low during write cycle, tHZWE must be met in the application. Do not apply input signal during this period. Data output from the previous READ operation will drive IO BUS.

DATA RETENTION CHARACTERISTICS

Symbol	Parameter	Test Condition	Min.	Typ. ⁽¹⁾	Max.	Unit	
V _{DR}	V _{DD} for Data Retention	See Data Retention Waveform	1.5	-	-	V	
I _{DR}	Data Retention Current	V _{DD} = V _{DR} (min), CS1# ≥ V _{DD} - 0.2V or CS2 ≤ 0.2V VIN ≤ 0.2V or VIN ≥ V _{DD} - 0.2V	25°C	-	3.0	5	uA
			85°C	-	-	6	
			125°C	-	-	18	
t _{SDR} ⁽²⁾	Data Retention Setup Time	See Data Retention Waveform	-	0	-	-	ns
t _{RDR}	Recovery Time	See Data Retention Waveform	-	t _{RC}	-	-	ns

Notes:

1. Typical values are measured at 25°C, V_{DD} = V_{DR} (min.), and not 100% tested.
2. V_{DD} power down slope must be longer than 100 us/volt when enter into Data Retention Mode.

DATA RETENTION WAVEFORM (CS1# CONTROLLED)

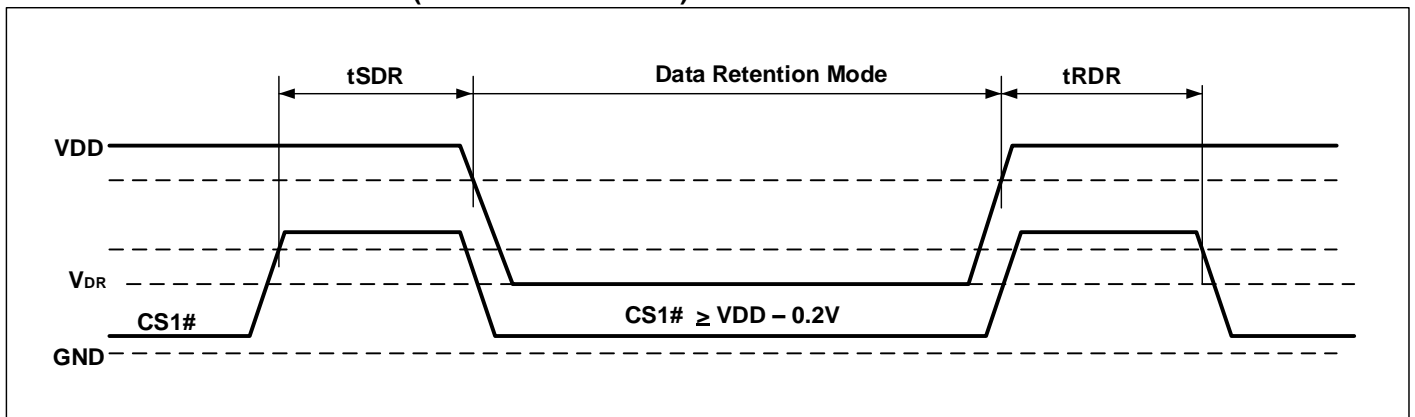

DATA RETENTION WAVEFORM (CS2 CONTROLLED)

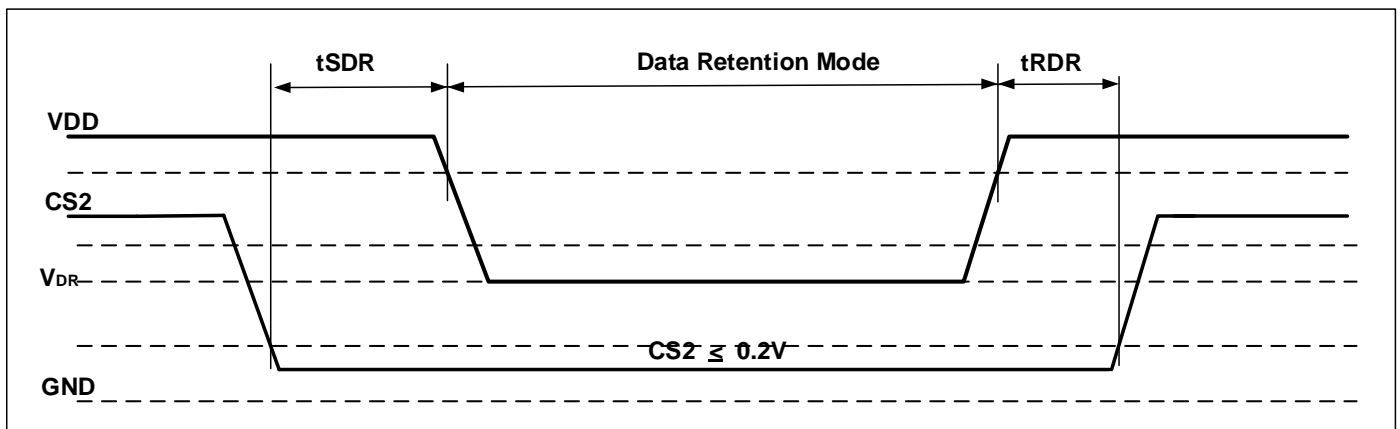

ORDERING INFORMATION

IS62WV2568FALL (1.65V - 2.2V)

Industrial Range: -40°C to $+85^{\circ}\text{C}$

Speed (ns)	Order Part No.	Package
55	IS62WV2568FALL-55TLI	TSOP (Type I, 8x20mm), Lead-free
55	IS62WV2568FALL-55BI	mini BGA (6mm x 8mm)
55	IS62WV2568FALL-55BLI	mini BGA (6mm x 8mm), Lead-free
55	IS62WV2568FALL-55HLI	sTSOP (Type I, 8x13.4mm), Lead-free

IS62WV2568FBLL (2.2V - 3.6V)

Industrial Range: -40°C to $+85^{\circ}\text{C}$

Speed (ns)	Order Part No.	Package
45	IS62WV2568FBLL-45TLI	TSOP (Type I, 8x20mm), Lead-free
45	IS62WV2568FBLL-45BI	mini BGA (6mm x 8mm)
45	IS62WV2568FBLL-45BLI	mini BGA (6mm x 8mm), Lead-free
45	IS62WV2568FBLL-45HLI	sTSOP (Type I, 8x13.4mm), Lead-free

Automotive Range (A3): -40°C to $+125^{\circ}\text{C}$

Speed (ns)	Order Part No.	Package
55	IS65WV2568FBLL-55CTLA3	TSOP (Type I, 8x20mm), Lead-free, Copper Leadframe
55	IS65WV2568FBLL-55BLA3	mini BGA (6mm x 8mm), Lead-free

PACKAGE INFORMATION

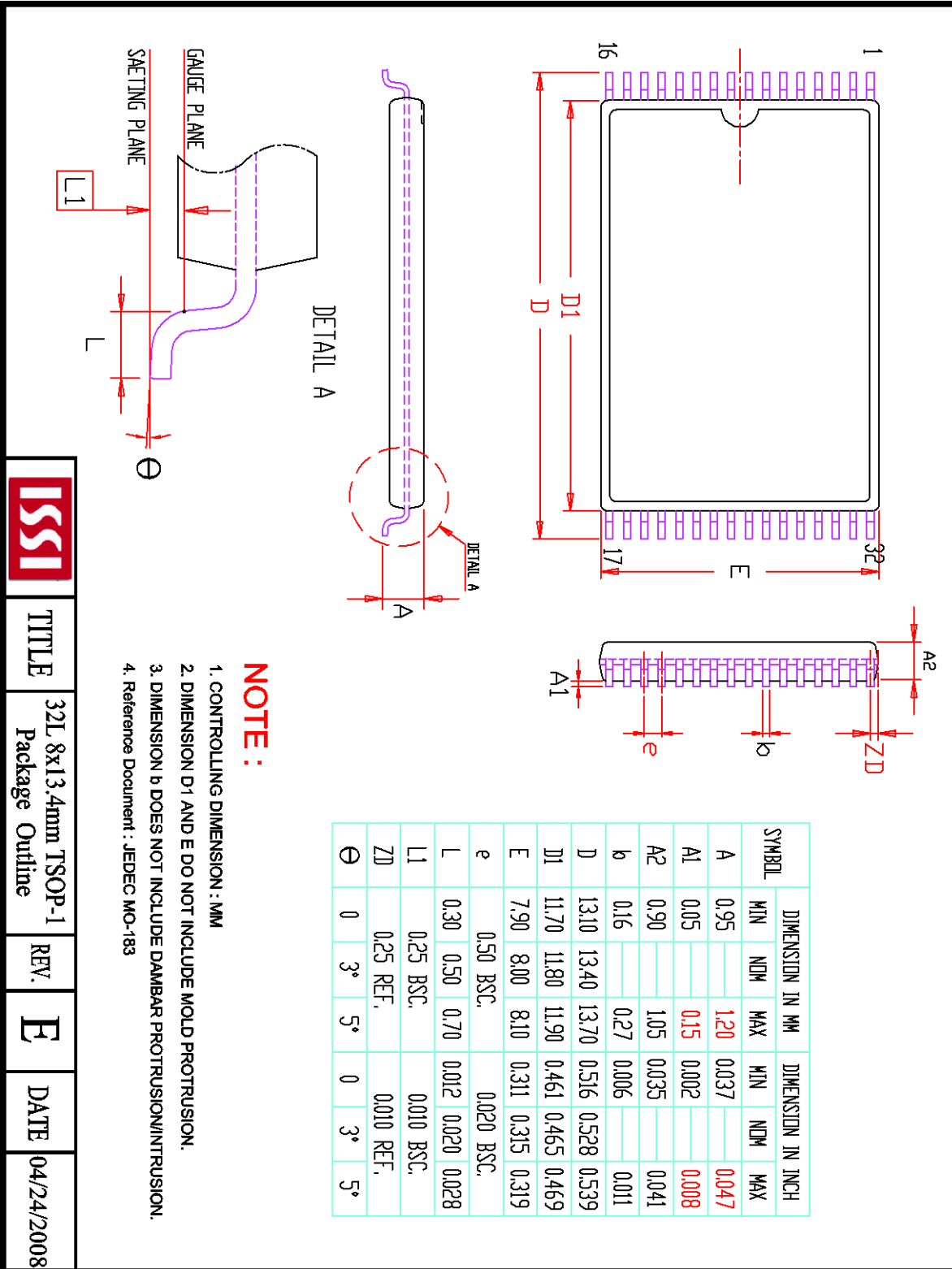

	TITLE	32L 8x13.4mm TSOP-1 Package Outline	REV.	E	DATE	04/24/2008
--	-------	----------------------------------------	------	---	------	------------

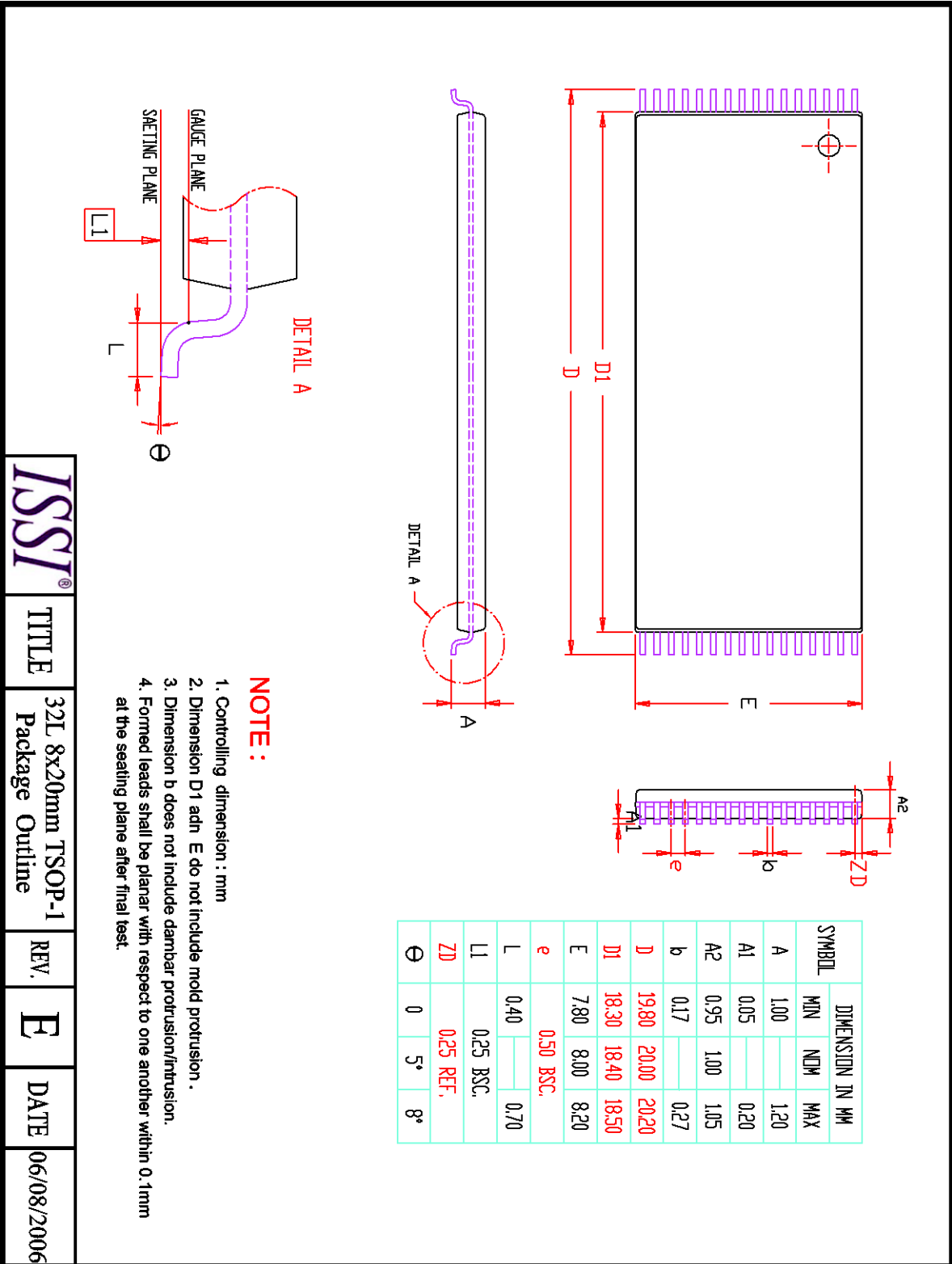

SYMBOL	DIMENSION IN MM		
	MIN	NOM	MAX
A	1.00		1.20
A1	0.05		0.20
A2	0.95	1.00	1.05
b	0.17		0.27
D	19.80	20.00	20.20
D1	18.30	18.40	18.50
E	7.80	8.00	8.20
e		0.50 BSC.	
L	0.40		0.70
L1		0.25 BSC.	
ZD		0.25 REF.	
\ominus	0	5°	8°

NOTE :

1. Controlling dimension : mm
2. Dimension D1 adn E do not include mold protrusion .
3. Dimension b does not include dambar protrusion/intrusion.
4. Formed leads shall be planar with respect to one another within 0.1mm at the seating plane after final test.

ISSI®	TITLE	REV.	E	DATE	06/08/2006
	32L 8x20mm TSOP-1 Package Outline				

