

AVERY DENNISON MARKETING SPECIFICATION

HISTORY		
REV.	DATE	DESCRIPTION
B	3.10.15	ADDED MIN INSTALL TEMP; UL LOGO AND 5000 PER CASE CHG LOOP TENSILE TO NEWTONS

THE SUBJECT MATTER DISCLOSED HEREIN EMBODIES PROPRIETARY INFORMATION WHICH IS THE CONFIDENTIAL PROPERTY OF THE AVERY DENNISON CO. NONE OF WHICH SHALL BE COPIED, REPRODUCED, DISCLOSED TO OTHERS, PUBLISHED OR USED IN WHOLE OR IN PART, FOR ANY PURPOSE OTHER THAN THAT FOR WHICH IT IS BEING MADE AVAILABLE WITHOUT THE EXPRESS ADVANCE WRITTEN PERMISSION OF A DULY AUTHORIZED AGENT OF THE COMPANY. THIS DOCUMENT IS THE PROPERTY OF THE AVERY DENNISON CO. AND IS TO BE RETURNED TO THE COMPANY ON DEMAND.

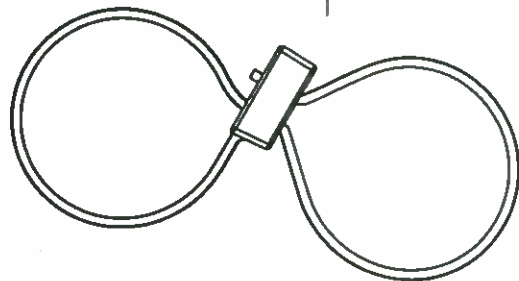
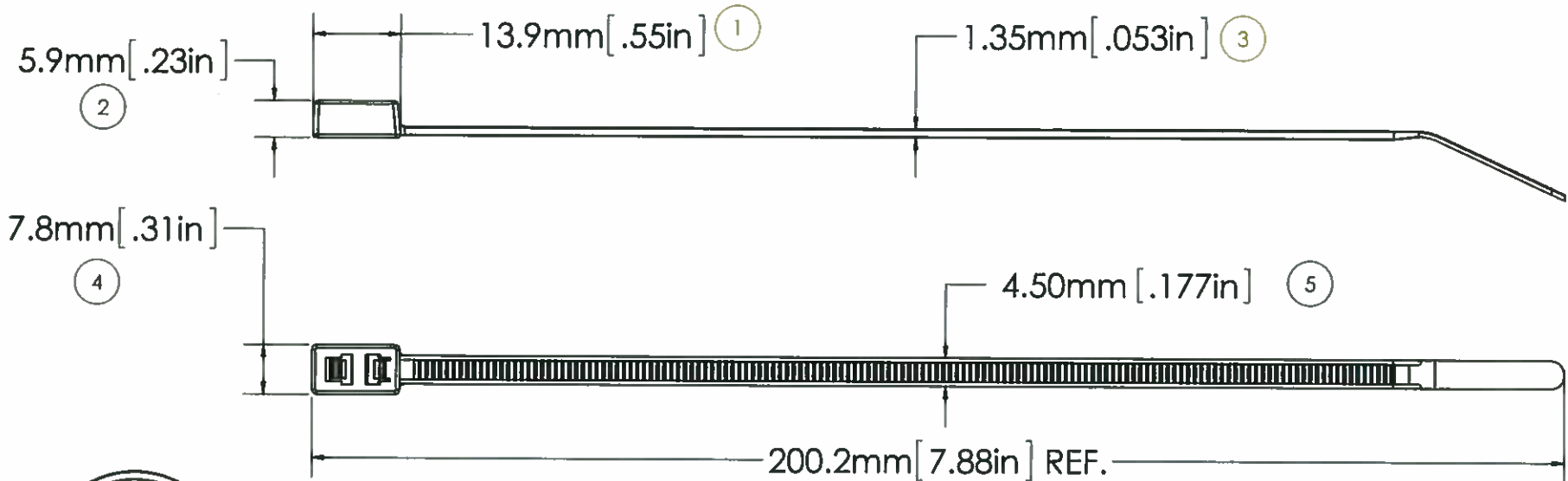

ASSEMBLED VIEW



LOOP TENSILE STRENGTH:	50 LBF / 220N MIN. PER AS-23190
OPERATING TEMP RANGE:	-40°F (-40°C) TO 221°F (105°C)
MIN. INSTALLATION TEMP.:	32°F(0°C)
WEIGHT:	0.04864 OZ./1.43 GRAMS
BUNDLE DIAMETER:	Ø.63" MIN TO: ONE LOOP UP TO Ø 1.5" OR TWO LOOPS UP TO Ø 0.75" EACH
TOOL:	12001 - HAND INSTALLATION TOOL 12500 - PNEUM. INSTALLATION TOOL
TOOL TENSION SETTING:	6 - 8
PACKAGING:	100/BAG 5000/CASE

NOTE: THESE CABLE TIES ARE PLENUM RATED AND HAVE A FLAMMABILITY RATING OF V-2

APPROVALS:	ENG. APPR. <i>[Signature]</i> 3-13-15
	Q.A. APPR. <i>[Signature]</i> 3-13-15

SPECIFIED TOLERANCES ARE:	
.XX ± .03 IN.	.X ± .7 MM
.XXX ± .01 IN.	.XX ± .25 MM
ANGULAR: ± 2°	

MATERIAL	NYLON 6/6
COLOR	BLACK, HEAT STABILIZED

AVERY DENNISON <small>FASTENER DIVISION FITCHBURG, MA 01420 U.S.A. TEL. 1-800-225-5913 FAX. 978-353-8157</small>	DESCRIPTION	7.5" CABLE TIE, STD, DOUBLE HEADED
	STOCK NO.	10428-0
REV.	B	