

SSD

Solid State Drive

ADLINK SSD Products



ADLINK industrial grade solid state drives (SSDs) are designed to provide high performance, low power consumption, high reliability and high capacity in 2.5" and 1.8" form factors. Optimized for high-throughput data transfers, ADLINK ASD SSDs are ideal for telecom server, defense, transportation and industrial applications.

Built on high speed SLC/MLC NAND flash and advanced controller technology, ADLINK ASD SATA SSDs deliver high speed sustained sequential read/write performance of up to 480MB/s and 410MB/s, respectively, at 512 GB capacity. By utilizing single level cell (SLC) NAND technology, the ADLINK SLC line of SSDs provides increased reliability and longer life cycle for mission critical applications.

Designed to industrial grade specifications, ADLINK ASD SSDs are available in both commercial (0°C to +70°C) and industrial (-40°C to +85°C) operating temperature ranges. Strict shock and vibration tests are performed to ensure that ADLINK ASD SSDs meet the needs of the most demanding applications.

Features

- SATA 6 Gb/s interface, backward compatible with SATA 3 Gb/s and 1.5 Gb/s
- SATA 3 Gb/s interface, backward compatible with SATA 1.5 Gb/s
- High performance: Up to 480//410 MB/s sustained sequential read/write speed
- Toshiba 32nm/ 24nm SLC and 24nm/ 19nm MLC
- From 32 GB to 512 GB, capacity in 2.5", 1.8" and mSATA form factor
- Real Performance – designed for and tested with realistic data sets resulting in consistent performance
- Clean Sweep Technology – junk data is continuously removed to ensure "clean state" read/write speeds
- High IOPS – selected models feature >60,000 IOPS
- High reliability for demanding environments; withstands extreme shock and vibration
- Compatible with most operating systems and platforms
- Long product life cycle

Target Applications

- Telecom and datacenter servers
- Military
- Transportation
- Robotic systems
- ATM and kiosk
- Medical
- Industrial automation

ASD SATA SSD

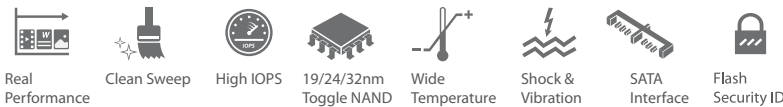

Selection Guide



Model	ASD26-MLC	ASD26-HA2	ASD26-MA2	ASD25-SLC
Form Factor	2.5"	2.5"	2.5"	2.5"
Connector	7+15 Pin male	7+15 Pin male	7+15 Pin male	7+15 Pin male
Interface	SATA 6.0Gb/s (SATA 3.0Gb/s & SATA 1.5Gb/s compatible)	SATA 3.0Gb/s (SATA 1.5Gb/s compatible)		SATA 6.0Gb/s (SATA 3.0Gb/s & SATA 1.5Gb/s compatible)
Flash Memory	MLC 24nm	SLC* 24nm	MLC 24nm	SLC 32nm
Capacity	32/64/128/256/512GB	16/32 GB	32/64 GB	32/64/128GB
Controller	Marvell 88SS9174	ADLINK AMSS1	ADLINK AMSS1	Marvell 88SS9174
Cache	256MB -512MB DDR3	64KB SRAM	64KB SRAM	128MB DDR3
Max. Sustained R /W Performance*	Read: 480MB/s Write: 410MB/s.	Read: 190MB/s Write: 100MB/s.	Read: 190MB/s Write: 75MB/s.	Read: 420MB/s Write: 380MB/s.
IPOS 4K Random	68,000/63,000	4,000/700	3,400/460	17,000/10,000
MTBF	>1.5M hours	>2M hours	>1.5M hours	>2M hours
Operating Temp.	Commercial: 0°C~ +70°C	Industrial: -40°C~ +85 °C		Commercial: 0°C~ +70°C Industrial: -40°C~ +85 °C
Dimensions (W xL xH)	69.85 x100 x9.5mm	69.85 x100 x9.5mm	69.85 x100 x9.5mm	69.85 x100 x9.5mm
Weight	80g (max.)	80g (max.)	80g (max.)	80g (max.)
Page Number	9-3	9-3	9-3	9-4

*SLC mode



Model	ASD19-SLC	ASD19-MLC	ASD18-MLC C2	ASDMS-MLC	ASDHS-MLC C2
Form Factor	1.8" enclosure	1.8" enclosure	1.8" openframe	mSATA	Half-Slim
Connector	7+9 Pin male	7+9 Pin male	7+9 Pin male	mSATA	7+15 Pin male
Interface	SATA 3.0Gb/s (SATA 1.5Gb/s compatible)	SATA 6.0Gb/s (SATA 3.0Gb/s & SATA 1.5Gb/s compatible)			
Flash Memory	SLC 25nm	MLC 24nm	MLC 24nm	MLC 19/ 24nm	MLC 24nm
Capacity	32/64/128GB	64/128/256GB	64/128GB	32/64/128/256GB	64GB
Controller	JMF616	Marvell 88SS9174	Marvell 88SS9174	Marvell 88SS9187	Marvell 88SS9174
Cache	64MB DDR	256MB DDR3	128MB DDR3	128MB DDR3	128MB DDR3
Max. Sustained R /W Performance*	Read: 260MB/s Write: 215MB/s.	Read: 480MB/s Write: 340MB/s.	Read: up to 480MB/s Write: up to 190MB/s.	Read: 480MB/s Write: 390MB/s.	Read: 350MB/s Write: 170MB/s.
IPOS 4K Random	4,500/10,000	60,000/55,000	65,000/43,000	60,000/61,000	48,000/38,000
MTBF	>2M hours	>1.5M hours	>1.5M hours	>1.5M hours	>1.5M hours
Operating Temp.	Industrial: -40°C~ +85 °C	Commercial: 0°C~ +70°C	Commercial: 0°C~ +70°C	Commercial: 0°C~ +70°C	Commercial: 0°C~ +70°C
Dimensions (W xL xH)	54 x 78.5 x 5 mm	54 x 78.3 x 5 mm	53.5 x 77.7 x 3.4 mm	29.9 x 50.8 x 3.4 mm	39.0 x 54.0 x 4 mm
Weight	36g (max.)	36g (max.)	19g (max.)	10g (max.)	10g (max.)
Page Number	9-5	9-5	9-6	9-7	9-8

*Performance index by ATTO Disk and CrystalDiskMark Benchmark. Speeds listed are for largest capacity of each model. (Actual performance dependent on specific application platform)

ASD26-MLC/MA2/HA2 Series 2.5" SATA SSD with MLC NAND Flash

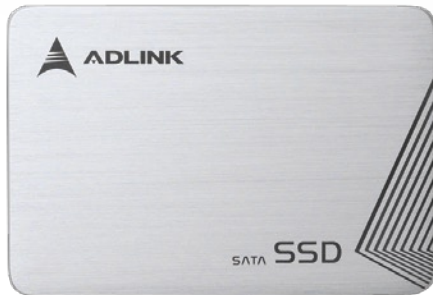

Features

- Sustained read up to 480 MB/s
- Sustained write up to 410 MB/s
- Capacity: 32, 64, 128, 256, 512 GB
- SATA 6 Gb/s interface (ASD26-MLC)
SATA 3 Gb/s interface (ASD26-MA2/ HA2)
- Toshiba 24nm MLC/ SLC model Toggle NAND Flash
- High IOPS (ASD26-MLC)
- Shock and vibration resistant

Specifications

Physical

Capacity	MLC 32, 64, 128, 256, 512GB SLC mode 16,32GB
Flash Components	Multi-Level Cell (MLC) NAND
Interface	SATA 6 Gb/s & SATA 3 Gb/s
Form Factor	2.5" form factor
Dimensions	100 x 68.85 x 9.5mm (L x W x H)
Weight	80 g

Performance

Bandwidth	ASD26-MLC
	32 GB: Sustained read/write up to 300/70 MB/s
	64 GB: Sustained read/write up to 440/160 MB/s
	128 GB: Sustained read/write up to 480/200 MB/s
	256 GB: Sustained read/write up to 480/340 MB/s
	512 GB: Sustained read/write up to 480/410 MB/s
	ASD26-MA2
	32 GB: Sustained read/write up to 190/40 MB/s
	64 GB: Sustained read/write up to 190/75 MB/s
	ASD26-HA2
	16/32 GB: Sustained read/write up to 190/100 MB/s
	Read and Write IOPS
32 GB: Random 4KB read/write up to 40,000/19,000	
64 GB: Random 4KB read/write up to 54,000/41,000	
128 GB: Random 4KB read/write up to 68,000/47,000	
256 GB: Random 4KB read/write up to 68,000/63,000	
512 GB: Random 4KB read/write up to 51,000/26,000	
ASD26-MA2	
32/64 GB: Random 4KB read/write up to 3,400/420	
ASD26-HA2	
16/32 GB: Random 4KB read/write up to 3,900/660	

Environmental

Operating Temperature	Industrial: -40°C~ +85 °C Commercial: 0°C to 70°C
Storage Temperature	Industrial: -40°C~ +85 °C
Shock	1,500 G, 0.5 ms
Vibration	Operating: 7~800 Hz, 2.17 Grms Non-operating: 7~800 Hz, 3.08 Grms
Certifications	UL, CE , RoHS, BSMI, Microsoft WHQL

Compatibility

SATA	SATA Revision 3.0 compliant: compatible with SATA 1.5 Gb/s, 3 Gb/s & 6 Gb/s interface (ASD26-MLC) SATA Revision 2.0 compliant: compatible with SATA 1.5 Gb/s, 3 Gb/s interface (ASD26-MA2/ HA2) ATA/ATAPI- 8 compliant SSD enhanced SMART ATA feature set Native Command Queuing (NCQ) command set TRIM supported
------	--

Power Requirements

Management	5V SATA SATA interface power management OS-aware hot plug/removal
Connector	15-pin SATA connector for DC 5V input

Reliability

MTBF	SLC mode 2M hours, MLC 1.5M hours
Long Life Support	Minimum of 3 years useful life

Ordering Information

Model Number	Description/Configuration
ASD26-MLC32G-CT	2.5" SATA 6 Gb/s SSD 32 GB , MLC type, (0°C~70°C)
ASD26-MLC64G-CT	2.5" SATA 6 Gb/s SSD 64 GB , MLC type, (0°C~70°C)
ASD26-MLC128G-CT	2.5" SATA 6 Gb/s SSD 128 GB , MLC type, (0°C~70°C)
ASD26-MLC256G-CT	2.5" SATA 6 Gb/s SSD 256 GB, MLC type, (0°C ~70°C)
ASD26-MLC512G-CT	2.5" SATA 6 Gb/s SSD 512 GB, MLC type, (0°C ~70°C)
ASD26-MA2032-ET	2.5" SATA 3 Gb/s SSD, 32GB, 24nm MLC, (-40°C~+85°C)
ASD26-MA2064-ET	2.5" SATA 3 Gb/s SSD, 64GB, 24nm MLC(-40°C~+85°C)
ASD26-HA2016-ET	2.5" SATA 3 Gb/s SSD, 16GB, 24nm SLC mode, (-40°C~+85°C)
ASD26-HA2032-ET	2.5" SATA 3 Gb/s SSD, 32GB, 24nm SLC mode, -40°C~+85°C)

Dimensions

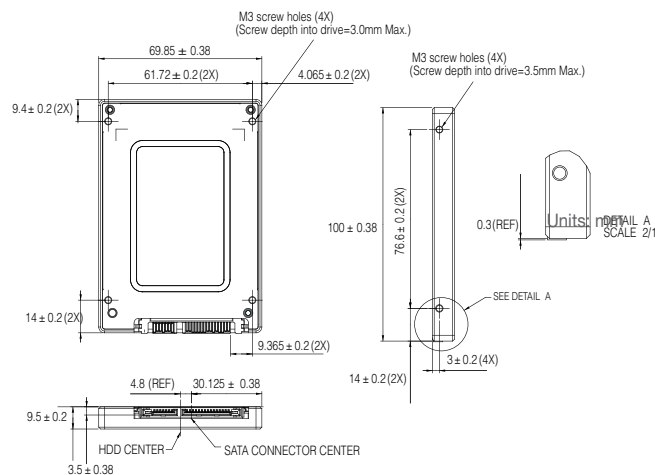

ASD25-SLC Series

2.5" SATA 6 Gb/s SSD with SLC NAND Flash

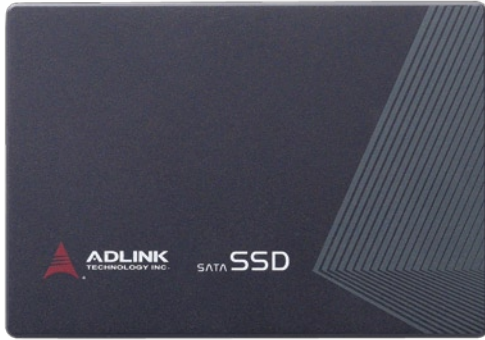

Features

- Sustained read up to 420 MB/s
- Sustained write up to 380 MB/s
- Capacity: 32, 64, 128 GB
- SATA 6 Gb/s interface
- Single-Level Cell NAND Flash for longer life
- Industrial Temperatures: -40°C~85°C
- Shock and vibration resistant

Specifications

Physical

Capacity	32, 64, 128 GB
Flash Components	Single-Level Cell (SLC) NAND
Interface	SATA 6 Gb/s
Form Factor	2.5" form factor
Dimensions	100 x 68.85 x 9.5mm (L x W x H)
Weight	80 g

Performance

Bandwidth	32 GB: Sustained read/write up to 360/170 MB/s
	64 GB: Sustained read/write up to 400/275 MB/s
	128 GB: Sustained read/write up to 420/380 MB/s
Read and Write IOPS	32 GB: Random 4KB read/write up to 17,000/8,500 IOPS
	64 GB: Random 4KB read/write up to 17,500/11,000 IOPS
	128 GB: Random 4KB read/write up to 17,000/10,000 IOPS
Power On to Ready	<1.0 sec

Environmental

Operating Temperature	Commercial: 0°C to 70°C
	Industrial: -40°C to 85°C
Storage Temperature	-40°C to 85°C
Shock	1,500 G, 0.5 ms
Vibration	Operating: 7~800Hz, 2.17 Grms
	Non-operating: 7~800Hz, 3.08 Grms
Certifications	UL, CE, RoHS, Microsoft WHQL

Compatibility

SATA	SATA Revision 3.0 compliant: compatible with SATA 1.5 Gb/s, 3 Gb/s & 6 Gb/s interface
	ATA/ATAPI- 8 compliant
	SSD enhanced SMART ATA feature set
	Native Command Queuing (NCQ) command set
	TRIM supported

Power Requirements

Management	5V SATA SATA interface power management OS-aware hot plug/removal
Connector	15-pin SATA connector for DC 5V input

Reliability

MTBF	> 2,000,000 hours
Life Cycle	Minimum of 5 years useful life

Ordering Information

Model Number	Description/Configuration
ASD25-SLC32G-ET	2.5" SATA 6 Gb/s SSD 32 GB, SLC type, (-40°C~85°C)
ASD25-SLC64G-ET	2.5" SATA 6 Gb/s SSD 64 GB, SLC type, (-40°C~85°C)
ASD25-SLC128G-ET	2.5" SATA 6 Gb/s SSD 128 GB, SLC type, (-40°C~85°C)
ASD25-SLC32G-CT	2.5" SATA 6 Gb/s SSD 32 GB, SLC type, (0°C~70°C)
ASD25-SLC64G-CT	2.5" SATA 6 Gb/s SSD 64 GB, SLC type, (0°C~70°C)
ASD25-SLC128G-CT	2.5" SATA 6 Gb/s SSD 128 GB, SLC type, (0°C~70°C)

Dimensions

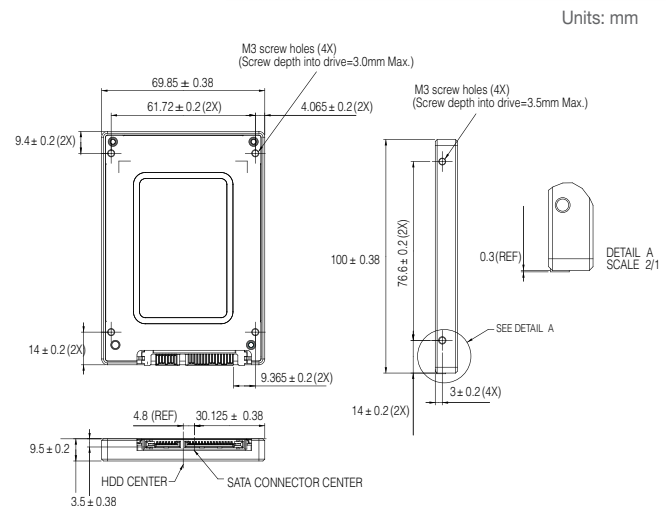

ASD19-SLC/ MLC Series

1.8" SATA SSD with SLC/MLC NAND Flash



Features

- Sustained read up to 480 MB/s
- Sustained write up to 400 MB/s
- Capacity:
 - SLC: 32, 64, 128 GB
 - MLC: 128, 256, 512 GB
- SATA 6 Gb/s interface
- Toshiba 24nm MLC/ Micron 25nm SLC NAND Flash
- Shock and vibration resistant
- High IOPS (ASD19-MLC)

Specifications

Physical

Capacity	SLC: 32, 64, 128 GB MLC: 128, 256 GB
Flash Components	Single-Level Cell NAND (ASD19-SLC) Multi-Level Cell NAND (ASD19-MLC)
Interface	SATA 6 Gb/s (ASD19-MLC) SATA 3 Gb/s (ASD19-SLC)
Form Factor	1.8" form factor
Dimensions	78.5 x 54 x 5 mm (L x W x H)
Weight	36 g (without case)

Performance

Bandwidth	SLC
	32 GB: Sustained read/write up to 260/190 MB/s 64 GB: Sustained read/write up to 260/215 MB/s 128 GB: Sustained read/write up to 250/170 MB/s
	MLC
	128 GB: Sustained read/write up to 480/170 MB/s 256 GB: Sustained read/write up to 480/340 MB/s
Read and Write IOPS	SLC
	32 GB: Random 4KB read/write up to 4,500/10,000 IOPS 64 GB: Random 4KB read/write up to 4,500/10,000 IOPS 128 GB: Random 4KB read/write up to 4,500/10,000 IOPS
	MLC
	128 GB: Random 4KB read/write up to 68,000/45,000 IOPS 256 GB: Random 4KB read/write up to 44,000/20,000 IOPS
Power on to ready	<1.0 sec

Environmental

Operating Temperature	Commercial: 0°C to 70°C Industrial: -40°C to 85°C (SLC only)
Storage Temperature	-40°C to 85°C
Shock	1,500 G, 0.5 ms
Vibration	Operating: 7-800 Hz, 2.17 Grms Non-operating: 7-800 Hz, 3.08 Grms
Certifications	UL, CE, RoHS

Compatibility

SATA	SATA Revision 3.0 compliant: compatible with SATA 1.5 Gb/s, 3 Gb/s & 6 Gb/s interface SATA Revision 2.0 compliant: compatible with SATA 1.5 Gb/s, 3 Gb/s interface (ASD19-SLC) ATA/ATAPI- 8 compliant SSD enhanced SMART ATA feature set Native Command Queuing (NCQ) command set TRIM supported
------	---

Power Requirements

Management	3.3V micro SATA SATA interface power management OS-aware hot plug/removal
Connector	9-pin SATA connector for DC 3.3V input

Reliability

MTBF	SLC 2M hours, MLC 1.5M hours
Long Life Support	Minimum of 3 years useful life

Ordering Information

Model Number	Description/Configuration
ASD19-SLC32G-ET	1.8" Micro SATA 3 Gb/s SSD 32 GB, SLC type, (-40°C~85°C)
ASD19-SLC64G-ET	1.8" Micro SATA 3 Gb/s SSD 64 GB, SLC type, (-40°C~85°C)
ASD19-SLC128G-ET	1.8" Micro SATA 3 Gb/s SSD 128 GB, SLC type, (-40°C~85°C)
ASD19-MLC128G-CT	1.8" Micro SATA 6 Gb/s SSD 128 GB, MLC type, (0°C~70°C)
ASD19-MLC256G-CT	1.8" Micro SATA 6 Gb/s SSD 256 GB, MLC type, (0°C~70°C)

Dimensions

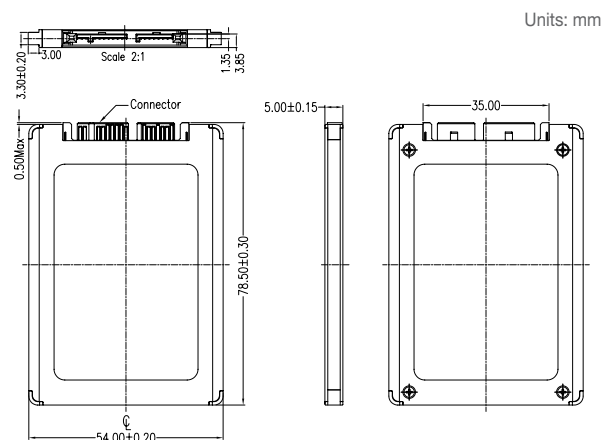

ASD18-MLC Series

1.8" SATA 6 Gb/s SSD with MLC NAND Flash

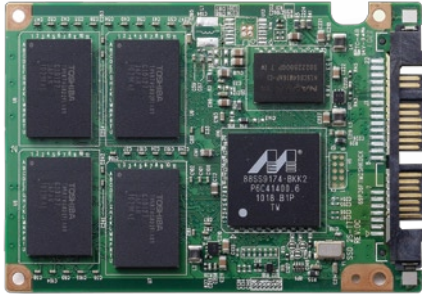

Features

- Sustained read up to 480 MB/s
- Sustained write up to 190 MB/s
- Capacity: 64, 128, 256 GB
- SATA 6 Gb/s interface
- Toshiba 24nm MLC Toggle NAND Flash
- Shock and vibration resistant

Specifications

Physical

Capacity	64, 128 GB
Flash Components	Multi-Level Cell (MLC) NAND
Interface	SATA 6 Gb/s
Form Factor	1.8" form factor
Dimensions	77.7 x 53.5 x 3.4 mm (L x W x H)
Weight	19 g (without case)

Performance

Bandwidth	64 GB: Sustained read/write up to 380/100 MB/s 128 GB: Sustained read/write up to 480/190 MB/s
Read and Write IOPS	64 GB: Random 4KB read/write up to 50,000/24,000 IOPS 128 GB: Random 4KB read/write up to 65,000/43,000 IOPS
Power On to Ready	<1.0 sec

Environmental

Operating Temperature	0°C to 70°C
Storage Temperature	-40°C to 85°C
Shock	1,500 G, 0.5 ms
Vibration	Operating: 7~800 Hz, 2.17 Grms Non-operating: 7~800 Hz, 3.08 Grms
Certifications	UL, CE, RoHS, Microsoft WHQL

Compatibility

SATA	SATA Revision 3.0 compliant: compatible with SATA 1.5 Gb/s, 3 Gb/s & 6 Gb/s interface ATA/ATAPI-8 compliant SSD enhanced SMART ATA feature set Native Command Queuing (NCQ) command set TRIM supported
------	--

Power Requirements

Management	3.3V micro SATA SATA interface power management OS-aware hot plug/removal
Connector	9-pin SATA connector for DC 3.3V input

Reliability

MTBF	> 1,500,000 hours
Long Life Support	Minimum of 3 years useful life

Ordering Information

Model Number	Description/Configuration
ASD18-MLC64G-C2	1.8" Micro SATA 6 Gb/s SSD 64 GB, MLC type, (0°C~70°C)
ASD18-MLC128G-C2	1.8" Micro SATA 6 Gb/s SSD 128 GB, MLC type, (0°C~70°C)

Dimensions

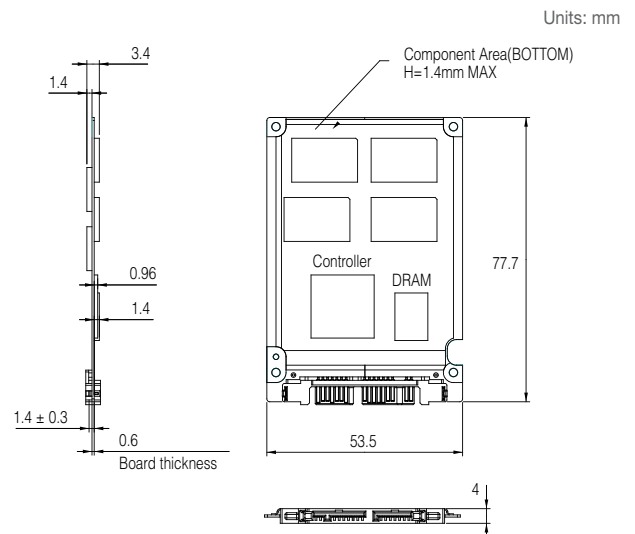

ASDMS-MLC Series

mSATA SATA 6 Gb/s SSD with MLC NAND Flash

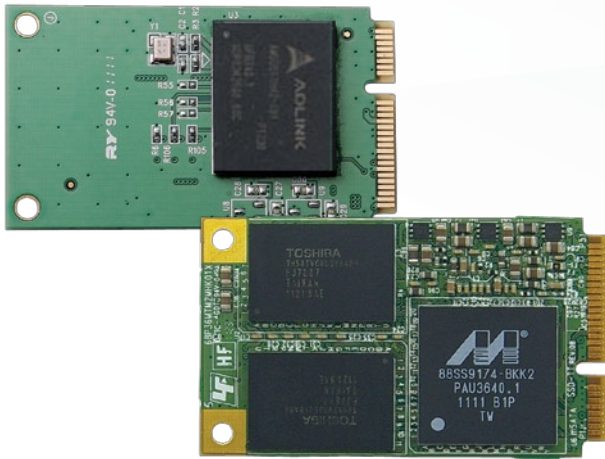

Features

- Sustained read up to 480 MB/s
- Sustained write up to 390 MB/s
- Capacity: 32, 64, 128, 256GB
- SATA 6 Gb/s interface
- Toshiba 19/ 24nm MLC Toggle NAND Flash
- Shock and vibration resistant
- High IOPS

Specifications

Physical

Capacity	32, 64, 128, 256GB
Flash Components	Multi-Level Cell (MLC) NAND
Interface	SATA 6Gb/s
Form Factor	mSATA (MO-300) form factor
Dimensions	50.8 (L) x 29.8 (W) x 3.40 mm (H)
Weight	10 g (Max.)

Performance

Bandwidth	32 GB: Sustained read/write up to 300/70 MB/s 64 GB: Sustained read/write up to 440/150 MB/s 128 GB: Sustained read/write up to 480/300 MB/s 256 GB: Sustained read/write up to 480/390 MB/s
Read and Write IOPS	32 GB: Random 4KB read/write up to 40,000/19,000 IOPS 64 GB: Random 4KB read/write up to 61,000/34,000 IOPS 128 GB: Random 4KB read/write up to 65,000/61,000 IOPS 256 GB: Random 4KB read/write up to 46,000/26,000 IOPS
Power on to ready	<1.0 sec

Environmental

Operating Temperature	Commercial: 0°C to 70°C
Storage Temperature	-40°C to 85°C
Shock	1,500G/0.5msec
Vibration	Operation: 7~800Hz, 2.17G (RMS) Non-operation: 7~800Hz, 3.08G (RMS)
Certifications	UL, CE, RoHS, Microsoft WHQL

Compatibility

SATA	SATA Revision 3.0 compliant: compatible with SATA 1.5 Gb/s, 3 Gb/s & 6 Gb/s interface
	ATA/ATAPI- 8 compliant
	SSD enhanced SMART ATA feature set
	Native Command Queuing (NCQ) command set
	TRIM supported

Power Requirements

Management	3.3V mSATA SATA interface power management OS-aware hot plug/removal
------------	--

Reliability

MTBF	1,500,000 hours
Life Cycle	Minimum of 3 years of useful life

Ordering Information

Model Number	Description/Configuration
ASDMS-MLC32G-CT	mSATA SATA 6 Gb/s SSD 32 GB, MLC type, (0°C~+70°C)
ASDMS-MLC64G-CT	mSATA SATA 6 Gb/s SSD 64 GB, MLC type, (0°C~+70°C)
ASDMS-MLC128G-CT	mSATA SATA 6 Gb/s SSD 128 GB, MLC type, (0°C~+70°C)
ASDMS-MLC256G-CT	mSATA SATA 6 Gb/s SSD 256 GB, MLC type, (0°C~+70°C)

Dimensions

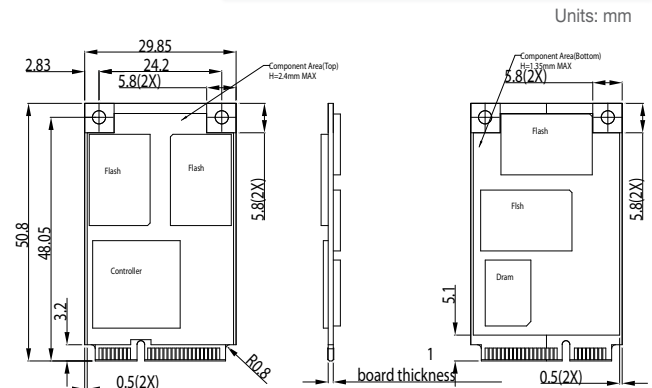

ASDHS-MLC/MA2/HA2 Series Half-Slim SATA SSD with MLC NAND Flash

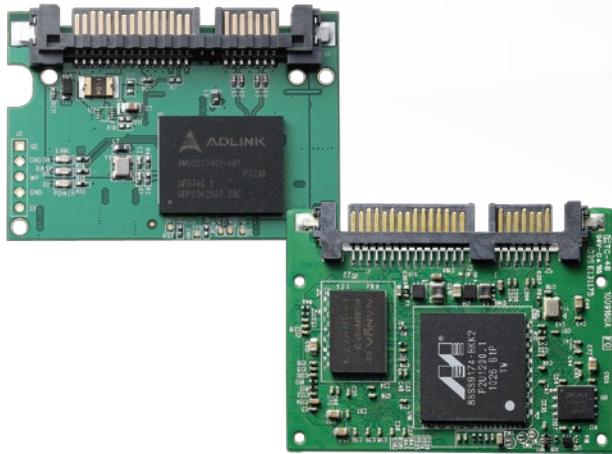

Features

- JEDEC mechanical specification MO-297
- Sustained read up to 350 MB/s
- Sustained write up to 170 MB/s
- 16, 32, 64GB capacity
- Toshiba 24nm MLC Toggle NAND Flash
- Shock and vibration resistant

Specifications

Physical

Capacity	MLC : 32, 64GB SLC mode : 16, 32GB
Flash Components	Multi-Level Cell (MLC) NAND/ SLC mode NAND
Interface	SATA 6Gb/s (ASDHS-MLC) SATA 3Gb/s (ASDHS-MA2/ HA2)
Form Factor	Half-Slim (JEDEC MO-297) form factor
Dimensions	39 x 54 x 4 mm (L x W x H)
Weight:	10 g (max.)

Performance

Bandwidth	SATA 6 Gb/s (ASDHS-MLC64G-C2) - Sustained read up to 350 MB/s - Sustained write up to 170 MB/s
Read and Write IOPS	SATA 6 Gb/s (ASDHS-MLC64G-C2) - Random 4KB Reads: up to 48,000 IOPS - Random 4KB Writes: up to 38,000 IOPS
Power On to Ready	<1.0 sec

Environmental

Operating Temperature	Commercial: 0°C to 70°C Industrial: -40°C to 85°C
Storage Temperature	-40°C to 85°C
Shock	1,500 G, 0.5 ms
Vibration	- Operating: 7~800Hz, 2.17 Grms - Non-operating: 7~800Hz, 3.08 Grms
Certifications	UL, CE , RoHS

Compatibility

SATA	- SATA Revision 3.0 compliant: compatible with SATA 1.5 Gb/s, 3 Gb/s & 6 Gb/s interface (ASDHS-MLC) - SATA Revision 2.0 compliant: compatible with SATA 1.5 Gb/s, 3 Gb/s interface (ASDHS-MA2/HA2) - ATA/ATAPI- 8 compliant - SSD enhanced S.M.A.R.T. ATA feature set - Native Command Queuing (NCQ) command set - TRIM supported
------	--

Power Requirements

Management	- 5V SATA - SATA interface power management - OS-aware hot plug/removal
Connector	15-pin SATA connector for DC 5V input

Reliability

MTBF	SLC mode 2M hours, MLC 1.5M hours
Long Life Support	Minimum of 3 years of useful life

Ordering Information

Model Number	Description/Configuration
ASDHS-MLC64G-C2	Half-Slim 64GB SATA 6Gb/s SSD series, MLC type, CT(0°C~+70°C)
ASDHS-MA2032-ET	Half-Slim 32GB, 24nm MLC, ET (-40°C~+85°C)
ASDHS-MA2064-ET	Half-Slim 64GB, 24nm MLC, ET (-40°C~+85°C)
ASDHS-HA2016-ET	Half-Slim 16GB, 24nm SLC mode, ET (-40°C~+85°C)
ASDHS-HA2032-ET	Half-Slim 32GB, 24nm SLC mode, ET (-40°C~+85°C)

Dimensions

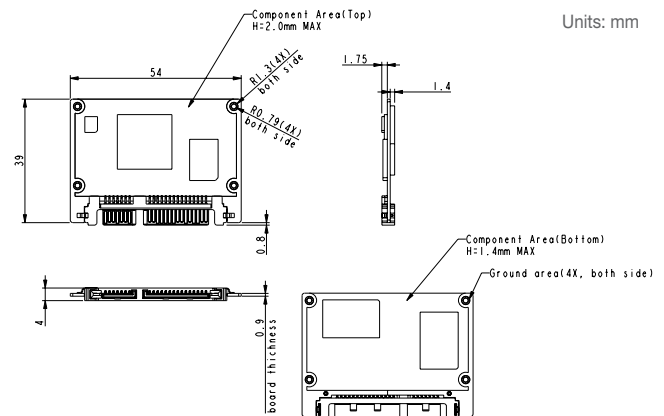

Model Index

A

AMC-1000	1-29
AMC-7000	1-31
ASD18-MLC	9-6
ASD19-SLC	9-5
ASD19-MLC	9-5
ASD25-SLC	9-4
ASD26-MLC	9-3
ASD26-MA2	9-3
ASD26-HA2	9-3
ASDHS-HA2	9-8
ASDHS-MA2	9-8
ASDHS-MLC	9-8
ASDMS-MLC	9-7
aTCA-3150	1-17
aTCA-3420	1-19
aTCA-6105A	1-13
aTCA-6155A	1-13
aTCA-6200A	1-11
aTCA-6250	1-9
aTCA-6900	1-15
aTCA-8202	1-27
aTCA-8214	1-21
aTCA-8505	1-25
aTCA-9300	1-5
aTCA-9700	1-3
aTCA-H8606	1-23
aTCA-N700	1-7
aTCA-R6155	1-32
aTCA-R6270	1-32
aTCA-R6905	1-32

C

cBP-306X	5-8
cBP-320X[R]	5-8
cBP-3213[R]	5-8
cBP-6103R	3-21
cBP-6104R	3-21

cBP-6105R	3-20
cBP-6402	3-19
cBP-6402R	3-19
cBP-6403R	3-21
cBP-6405R	3-20
cBP-6408R	3-20
cBP-6413DR	3-23
cBP-6415U	3-21
cBP-6418U	3-23
cBP-6609A	3-22
cBP-6614A	3-22
cPCI-3615	4-9
cPCI-3970	4-7
cPCI-3971	4-5
cPCI-6210	2-11
cPCI-6510	2-15
cPCI-6520	2-7
cPCI-6615	2-13
cPCI-6620	2-6
cPCI-6625	2-5
cPCI-6880	2-17
cPCI-6930	2-9
cPCI-R6500	2-21
cPCI-R6700	2-20
cPCIS-1100A	5-5
cPCIS-1202	5-6
cPCIS-2500	5-7
cPCIS-2600	5-2
cPCIS-2630	5-3
cPCIS-2632	5-3
cPCIS-2633	5-4
cPCIS-2642	5-5
cPCIS-2800	5-2
cPCIS-2830	5-3
cPCIS-2832	5-3
cPCIS-2833	5-4
cPCIS-2842	5-5
cPCIS-3300BLS	3-3

cPCIS-3320	3-7
cPCIS-3330	3-5
cPCIS-6130R	3-18
cPCIS-6230R	3-15
cPCIS-6235R	3-17
cPCIS-6240R	3-15
cPCIS-6400U	3-9
cPCIS-6400X	3-11
cPCIS-6418U	3-13
cPCIS-ET1102	5-6
cPCIS-ET2632	5-4
cPS-H325/24	5-9
cPS-H325/48	5-9
cPS-H325/AC	5-9
cPS-H640/48	3-24
cPS-H640/AC	3-24
cPS-P325/AC	5-10
CT-31	4-11
CT-61	2-19

E

EBP-10E5	7-22
EBP-13E2	7-22
EBP-13E4	7-22
EBP-16Q8	7-22
EBP-1UX4	7-22
EBP-5E1	7-21
EBP-7E2	7-21
EBP-9E2	7-21
EBP-D3E1	7-21
EBP-D3S1	7-21
EBP-D5E2	7-22

H

HPCI-13S4LU	7-24
HPCI-14S/ATX	7-24

HPCI-14S12U	7-24
HPCI-14S7U	7-24
HPCI-15S	7-24
HPCI-15S10	7-24
HPCI-19S18A	7-24
HPCI-6S4	7-23
HPCI-8S4	7-23
HPCI-9S7U	7-23
HPCI-D3S2	7-23
HPCI-D6S4	7-23

I

IMB-M40H	6-14
IMB-S90	6-17
IMB-T40H	6-12
IMB-T10	6-13

M

M-322	6-16
M-342	6-15
MI-220	6-11
MIX-110	7-16
MIX-220	7-11
MIX-250	7-17
MK-120	7-10

N

NuPRO-935A	6-8
NuPRO-A301	6-9
NuPRO-A331	6-7
NuPRO-A40H	6-6
NuPRO-E315	6-3
NuPRO-E320	6-5
NuPRO-E330	6-4
NuPRO-E340	6-2

R

RK-110S	7-2
RK-110SE	7-2
RK-210E	7-3
RK-210S	7-3
RK-260	7-4
RK-260MB	7-4
RK-410FS	7-5
RK-440	7-6
RK-460	7-7
RK-460MB	7-7
RK-606UC	7-12
RK-607B	7-13
RK-608B-E	7-14
RK-608MB-C	7-15
RK-610A	7-8
RK-610AM	7-8
RK-615FB	7-9

T

TRL-40	7-18
--------------	------

V

VPX-3000	4-12
----------------	------

X

XMC-E540	4-14
XMC-G640	4-14

