

THIS DOCUMENT IS THE PROPERTY OF APDM COMPONENTS AND SHALL NOT BE COPIED, REPRODUCED, DISCLOSED OR USED AS THE BASIS FOR MANUFACTURING OR SALE WITHOUT PERMISSION OF A DULY AUTHORIZED REPRESENTATIVE OF APDM COMPONENTS INC.

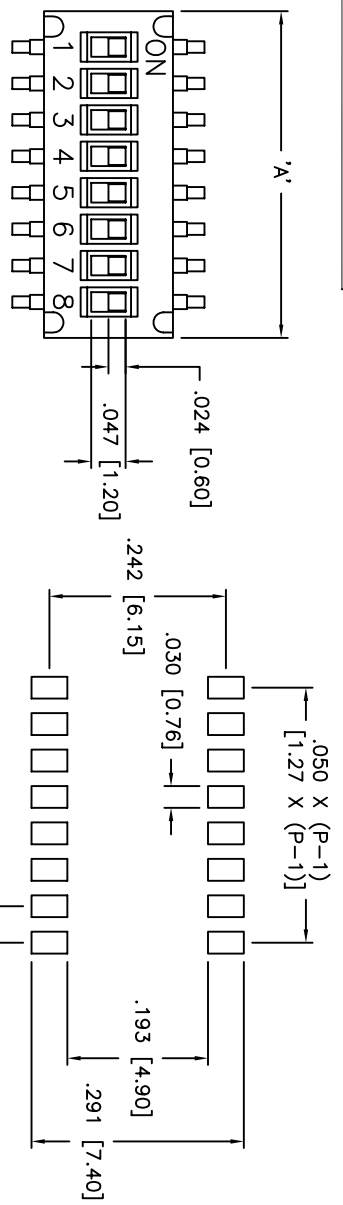

P.C. LAYOUT
UNLESS OTHERWISE SPECIFIED
P.C. TOLERANCES ARE ±.002 [0.05]

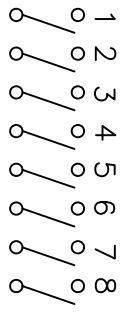
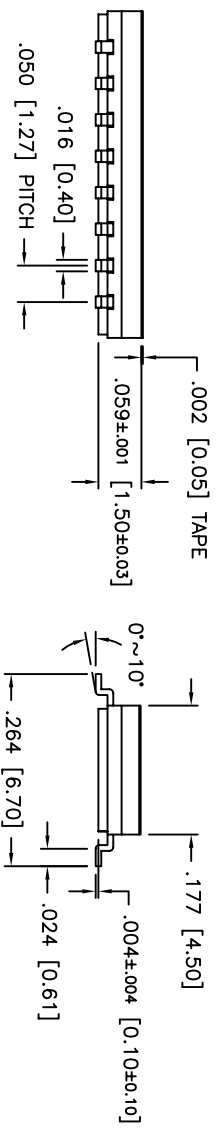

CIRCUIT DIAGRAM

MODEL NUMBER	NO. OF POSITIONS	DIMENSION 'A'
DHN02	2	.148 [3.77]
DHN04	4	.248 [6.31]
DHN06	6	.348 [8.85]
DHN08	8	.448 [11.39]
DHN10	10	.548 [13.93]

PROD. NO.: DHN*****
 PROD. SERIES: _____
 NUMBER OF POSITIONS: _____
 02 = 2
 04 = 4
 06 = 6
 08 = 8
 10 = 10

PAKAGING
 □ = TUBE
 T/R = TAPE & REEL

SEALING
 □ = REGULAR
 T = TOP TAPE SEAL
 □ = 3µ" GOLD MIM
 F = IN ON POSITION
 □ = 10µ" GOLD MIN.

DESCRIPTION: SURFACE MOUNT DIP SWITCH
 WITH TAPE SEAL OPTION.
 SPECIFICATIONS:

SWITCHING RATING: 25mA, 24VDC.
 NON-SWITCHING RATING: 100MA, 50VDC.
 CONTACT RESISTANCE: 100 MOHMS MAX
 DIELECTRIC STRENGTH: 300VAC for 1 MINUTE.
 INSULATION RESISTANCE: 100MOHMS MIN. AT 500VDC
 CAPACITANCE: 5PF AT 1MHZ±10KHZ MAX.
 OPERATING FORCE: 500 gf MAX.
 STROKE: 0.6mm

OPERATING TEMP: -40° to 85° C.
 STORAGE TEMP: -40° to 85° C.
 ELECTRICAL LIFE: 1,000 CYCLES.
 MECHANICAL LIFE: 1,000 OPERATIONS.
 CIRCUIT: 1 POLE 1 THROW.
 VIBRATION TEST: PASSES METHOD 201A. MIL-STD-202F.
 SHOCK TEST: 50g PER METHOD 213B. MIL-STD-202F.

MATERIALS:
 BASE & COVER: UL94V-0 NYLON HIGH-TEMP. THERMOPLASTIC
 COLOR, BLACK
 ACTUATOR: LCP HIGH-TEMP. THERMOPLASTIC.
 COLOR, WHITE
 CONTACT: PHOSPHOR BRONZE WITH GOLD PLATING
 TERMINAL: BRASS WITH GOLD PLATING
 TAPE: KAPTON
 SOLDERING:
 HAND SOLDERING: 350°C FOR 5 SECONDS MAX.
 REFLOW: 260°C FOR 5-10 SECONDS

DATE	SYM	REVISION RECORD	DWNL	CK
3/08	B	ECO# 785	CD	

APDM 63 Neck Rd. Hendersonville, NC 28839 (704) 233-7722 Fax: (704) 233-5554		PPN: CJD BR: _____ OR: _____ PJD
DESIGNS BY: _____ DIMENSION: _____ TOLERANCES (UNLESS OTHERWISE SPECIFIED) .XX±.02 [0.5] .XXX±.008 [0.20] .XXXX±.0008 [0.02] ANGLE = 40.5°	TITLE HALF PITCH DIP SWITCH	THIRD ANGLE PROJECTION
DO NOT SCALE DATE: 3/20/08	DRAWING NO. DHN*****	REV: B