

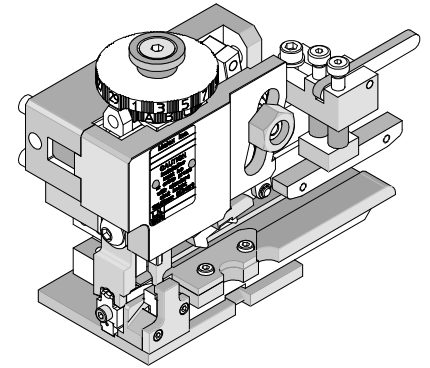

Rear Feed Mini-Mac Applicator Mechanical Feed Specification Sheet Order No. 63802-6300



FEATURES

- Directly adapts to most automatic wire processing machines
- Applicator designed to industry standard mounting and shut height 135.80mm (5.346")
- Quick set-up time; plus the crimp height, track and feed adjustments can be set without removing the applicator from the press
- Fine adjustment allows users to achieve target with little effort by adjusting in increments of .015mm (.0006") for conductor crimp height and .063mm (.0025") for insulation height
- Independent adjustment rings allow users to quickly adjust the conductor or insulation crimp height without affecting each other

SCOPE

Products: Flag Avikrimp™ Quick Disconnect Female Terminals, 14-16 AWG.

Terminal Order No.	Terminal Eng. No.	Wire Size		Tab Size		Insulation Diameter Maximum		Strip Length	
		AWG	mm ²	mm	In.	mm	In.	mm	In.
19006-0014	BB-5221Z	14-16	2.00-1.30	6.35 by 0.81	.250 by .032	4.32	.170	8.70	.344
19006-0023	BB-5224Z	14-16	2.00-1.30	4.75 by 0.51	.187 by .020	4.32	.170	8.70	.344
19006-0024	BB-5225Z	14-16	2.00-1.30	4.75 by 0.81	.187 by .032	4.32	.170	8.70	.344

DEFINITION OF TERMS

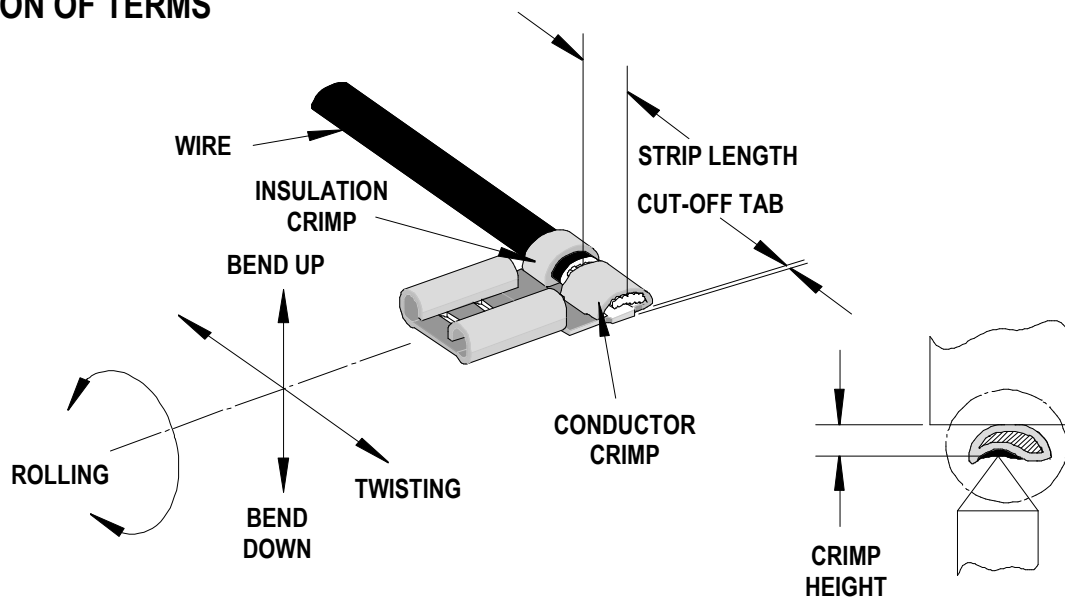

The above terminal drawing is a generic terminal representation. It is not an image of a terminal listed in the scope.

CRIMP SPECIFICATIONS

Terminal Order No.	Terminal Eng. No.	Wire Size		Conductor Crimp Height						Pull Force Minimum	
				Mean		Go		No Go			
		AWG	mm ²	mm	In.	mm	In.	mm	In.	N	Lb.
19006-0014	BB-5221Z	14	2.00	2.23	.088	2.15	.085	2.31	.091	222.6	50.0
		16	1.30							133.5	30.0
19006-0023	BB-5224Z	14	2.00	2.23	.088	2.15	.085	2.31	.091	222.6	50.0
		16	1.30							133.5	30.0
19006-0024	BB-5225Z	14	2.00	2.23	.088	2.15	.085	2.31	.091	222.6	50.0
		16	1.30							133.5	30.0

Seam
Seam shall not be open and no wire allowed out of the crimping

Pull Force should be measured with no influence from the insulation crimp. The above specifications are guidelines to an optimum crimp.

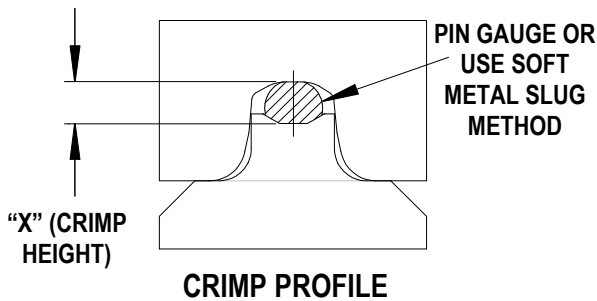

Use gauge pins or soft metal slug (solder) method to measure the "X" dimension. Verify tooling crimp height calibration by referring to the Go/No Go dimensions shown in the chart below.

Molex does not sell gauge pins contact your local industrial supplier.

PARTS LIST

Rear Feed Mini-Mac Applicator 63802-6300				
Item No.	Order No.	Engineering No.	Description	Quantity
Perishable Tooling				
	63802-6370	63802-6370	Tool Kit (All "Y" Items)	REF
1	63801-5512	63801-5512	Conductor Punch (E2 Die)	1 Y
2	19803-5281	19803-5281	Conductor Anvil (E1 Die)	1 Y
3	63801-5611	63801-5611	Insulation Punch (I2 Die)	1 Y
4	19803-5291	19803-5291	Insulation Anvil (I1 Die)	1 Y
5	19229-0120	23650-43	Cutter Housing	1 Y
6	19229-0121	23650-44	Cutter Plunger	1 Y
Other Components (REF 26350)				
7	19229-0095	23650-45	Cutter Back Plate	1
8	19230-0038	24854-08	Feed Finger	1
9	19230-0040	24854-18	Guide Rail	1
10	19230-0063	24853	Shoulder Bushing	1
11	19250-0004	24854-25	Guide and Hold Down	1
12	19250-0038	24855-23	Compression Spring	1
13	63801-2690	63801-2690	Terminal Drag Assembly	1
14	63801-7701	63801-7701	Cutter Striker	1
15	63803-5133	63803-5133	Conductor Bushing	1
Frame				
16	19230-0084	24854-05	Slide (Terminal Track)	1
17	63801-2600	63801-2600	Rear Feed Frame	1
18	63801-2603	63801-2603	Base	1
Hardware				
19	N/A	N/A	M3 by 10 Long SHCS	2**
20	N/A	N/A	M4 by 8 Long SHCS	6**
21	N/A	N/A	M4 by 8 Long BHCS	1**
22	N/A	N/A	M4 by 10 Long BHCS	1**
23	N/A	N/A	M4 by 12 Long SHCS	3**
24	N/A	N/A	M6 by 10 Long BHCS	6**
25	N/A	N/A	M8 by 20 Long BHCS	1**
26	N/A	N/A	6mm by 10 Long Dowel Pin	4**
** Available from an industrial supply company such as MSC (1-800-645-7270).				

NOTES

1. Molex recommends an extra perishable tooling kit be maintained at your facility.
2. Verify tooling alignment by manually cycling the press and Applicator before crimping under power. Check that all screws are tight.
3. Slugs, Terminals, Dirt and Oil should be kept clear of work area.
4. Wear safety glasses at all times.
5. For recommended maintenance refer to the Mini-Mac Manual.

CAUTION: This applicator should only be used in a press with a shut height of 135.80 mm (5.346"). Tooling damage could result at a lower setting.

CAUTION: To prevent injury never operate this Applicator without the guards supplied with the press or wire-processing machine in place. Reference the press or wire processing manufacturer's instruction manual.

CAUTION: Molex crimp specifications are valid only when used with Molex terminals, applicators and tooling.

Wear Safety Glasses At All Times.

Americas Headquarters
Lisle, Illinois 60532 U.S.A.
1-800-78MOLEX
amerinfo@molex.com

Far East North Headquarters
Yamato, Kanagawa, Japan
81-462-65-2324
feninfo@molex.com

Far East South Headquarters
Jurong, Singapore
65-6-268-6868
fesinfo@molex.com

European Headquarters
Munich, Germany
49-89-413092-0
eurinfo@molex.com

Corporate Headquarters
2222 Wellington Ct.
Lisle, IL 60532 U.S.A.
630-969-4550
Fax: 630-969-1352

Visit our Web site at <http://www.molex.com>