

THE INFORMATION CONTAINED IN THIS DRAWING IS THE SOLE PROPERTY OF ANDERSON POWER PRODUCTS. ANY REPRODUCTION IN PART OR WHOLE WITHOUT THE WRITTEN PERMISSION OF ANDERSON POWER PRODUCTS IS PROHIBITED.

Copyright 2015

ANDERSON POWER PRODUCTS RESERVES THE RIGHT TO ALTER PRODUCT TYPES, THEIR TECHNICAL DATA, DIMENSION, STYLE AND ACCESSORIES WITHOUT PRIOR NOTIFICATION.

INCLUDED TOOLS

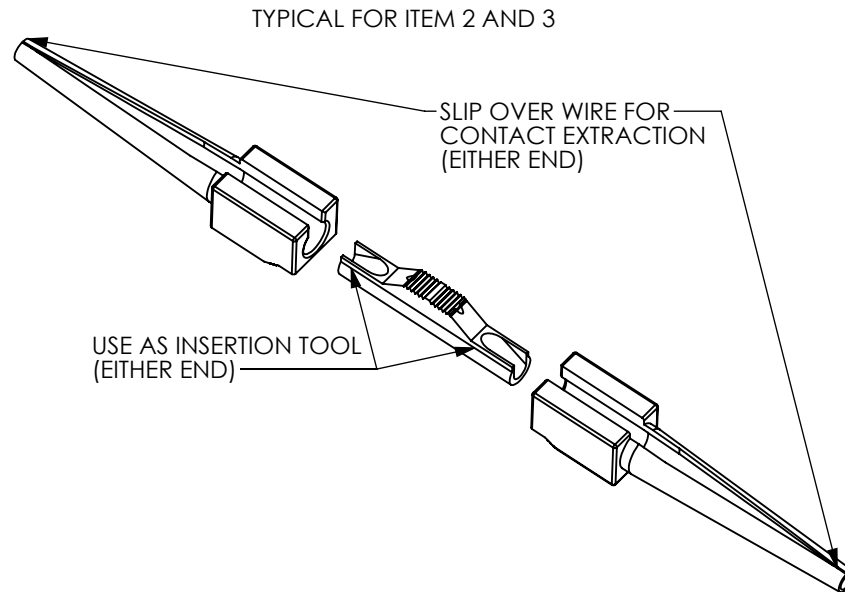
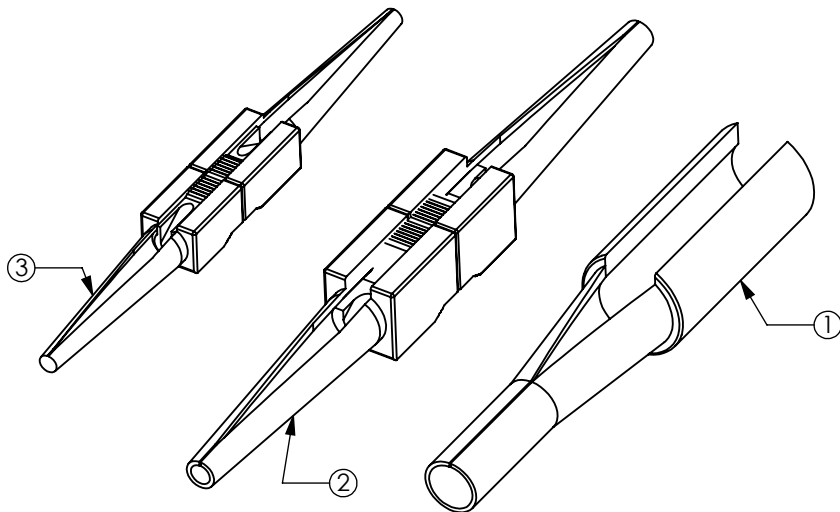

ITEM	QTY.	P/N	DESCRIPTION
1	1	M81969-14-06	#8 AWG (RED) PLASTIC EXTRACTION TOOL
2	1	M81969-14-04	#12 AWG (WH-YELLOW) PLASTIC INSERTION/EXTRACTION TOOL
3	1	M81969-14-11	#20 AWG (WH-RED) PLASTIC INSERTION/EXTRACTION TOOL

NOTES:

- TOOLS FOR USE WITH 75 AMP POWER DRAWER PIN AND SOCKET CONTACTS
- ITEMS 2 AND 3 USED FOR INSERTION AND EXTRACTION AS SHOWN IN EXPLODED VIEW
- ITEM 1 USED FOR EXTRACTION ONLY

DIMENSIONS ARE IN: MM [INCH]		APPROVALS		<p>ANDERSON POWER PRODUCTS</p> <p>TITLE</p> <p>CAT. NO. 100G2 INSERTION/EXTRACTION TOOLS FOR 75 AMP POWER DRAWER</p>
UNLESS OTHERWISE STATED		DRAWN	6/17/2015	
TOLERANCES:		CMS		
DECIMALS (INCH)	DECIMALS (MM)	CHECKED	6/24/2015	
.XX ±.02	.X ±.5	JYL		
SURFACE FINISH:		MFG APPRV	6/25/2015	
MACHINED	3.2µ [128µin]	CHB		
MOLDED	1.6µ [64µin]	QC APPRV	6/24/2015	
MATERIAL:		UFN		
FINISH:		ENG APPRV	6/24/2015	
		CLY		
SIZE	DWG NO.	REV.		
A	115449S1	0		
SCALE	CADFILE	SHEET		
NONE	04557	1 OF 1		

REV.	DESCRIPTION	APPRV	DATE
REVISIONS			