

THE INFORMATION CONTAINED HEREIN IS CONSIDERED 'PROPRIETARY' TO BEL FUSE INC. AND SHALL NOT BE COPIED, REPRODUCED OR DISCLOSED WITHOUT THE WRITTEN APPROVAL OF BEL FUSE INC.

LED1 POLARITY			LED2 POLARITY		
PIN 13	PIN 14	COLOR	PIN 15	PIN 16	COLOR
/	/	/	+	-	ORANGE
-	+	YELLOW	-	+	GREEN

RoHS
2002/95/EC

RJ45

ELECTRICAL CHARACTERISTICS @ 25°C

URNS RATIO

TP1	1CT : 1CT ±2%
TP2	1CT : 1CT ±2%
TP3	1CT : 1CT ±2%
TP4	1CT : 1CT ±2%

QCL @ 100kHz/100mVRMS

8mA DC BIAS 350µH MIN.

INS. LOSS

0.1MHz TO 1MHz	-1.1 dB MAX
1MHz TO 65MHz	-0.5 dB MAX
65MHz TO 100MHz	-0.8 dB MAX
100MHz TO 125MHz	-1.2 dB MAX

RET. LOSS (MIN) @ 100 OHMS ±15%

0.5MHz-40MHz	-18 dB
40MHz-100MHz	-12+20LOG(f/80MHz) dB

CM TO CM REJ

100kHz - 100MHz -30 dB MIN

CM TO DM REJ

100kHz - 100MHz -35 dB MIN

HIPOT (Isolation Voltage):

1500 Vrms
100% OF PRODUCTION TESTED TO COMPLY WITH
IEEE 802.3 ISOLATION REQUIREMENTS.

LED 1

VF (FORWARD VOLTAGE)	IF=20mA	YELLOW	2.1V TYP.
λ D (DOMINANT WAVELENGTH)	IF=20mA	YELLOW	590nm TYP.

LED 2

VF (FORWARD VOLTAGE)	IF=20mA	GREEN	2.2V TYP.
		ORANGE	2.0V TYP.
λ D (DOMINANT WAVELENGTH)	IF=20mA	GREEN	565nm TYP.
		ORANGE	610nm TYP.

SCHEMATIC

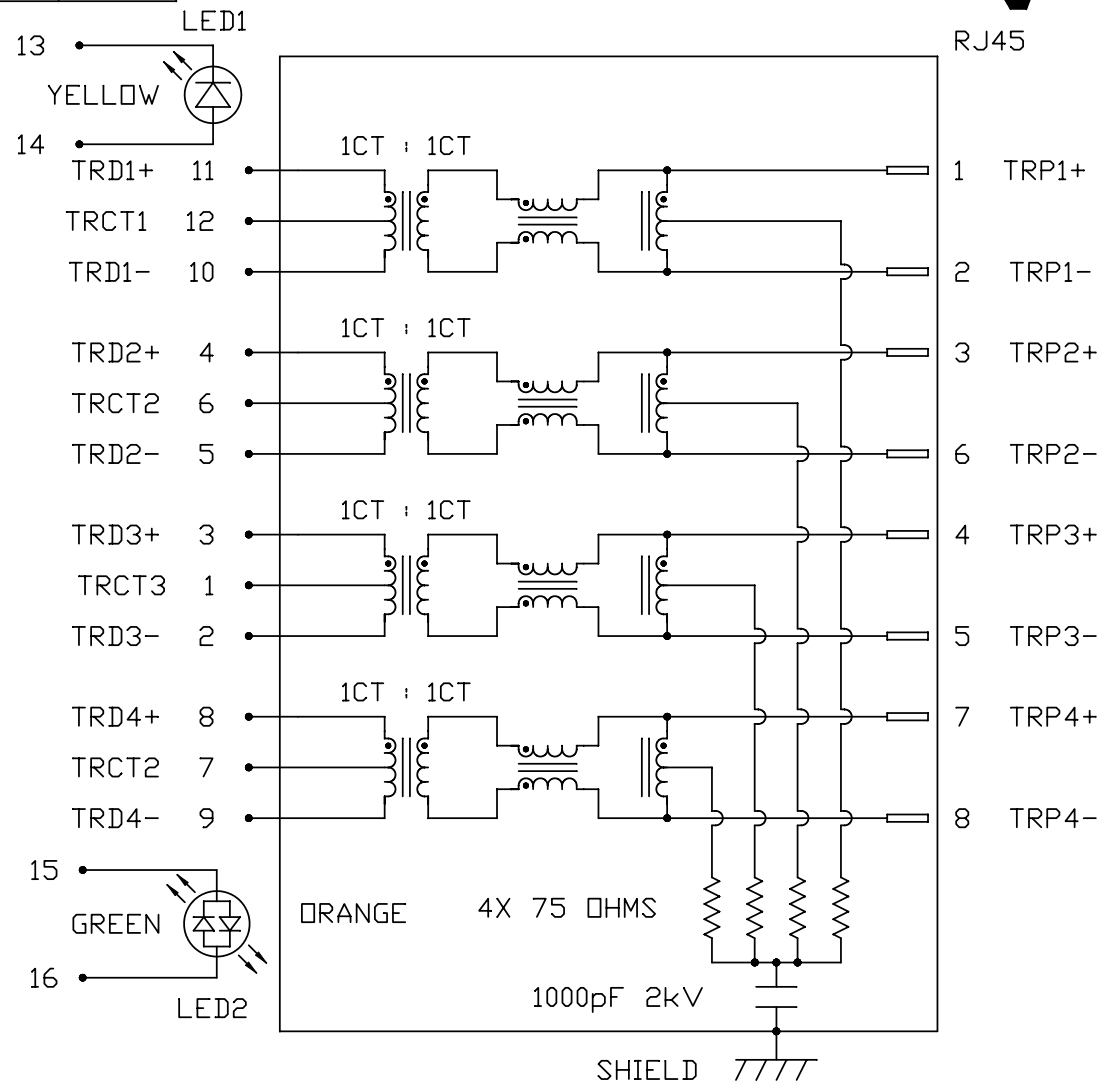

ORIGINATED BY	DATE	TITLE 1X4 gigabit MagJack® (12 cores, Tab Up)
CHOW WANGCHUNG	06-16-09	
DRAWN BY	DATE	
LI YONGFENG	06-16-09	0826-1X4T-23-F PATENTED

PART NO. / DRAWING NO.	STANDARD DIM.	[] METRIC DIM. AS REFERENCE
08261X4T23-F	TOL. IN INCH	UNIT : INCH [mm] REV. : F
FILE NAME	.X	SCALE : N/A SIZE : A4
08261X4T23-F_F.DWG	.XX	PAGE : 2
	.XXX	

08261X4T23-F
08261X4T23-F_F.DWG

UNIT : INCH [mm]	REV. : F
SCALE : N/A	SIZE : A4
PAGE : 2	



THE INFORMATION CONTAINED HEREIN IS CONSIDERED "PROPRIETARY" TO BEL FUSE INC. AND SHALL NOT BE COPIED, REPRODUCED OR DISCLOSED WITHOUT THE WRITTEN APPROVAL OF BEL FUSE INC.

RoHS
2002/95/EC

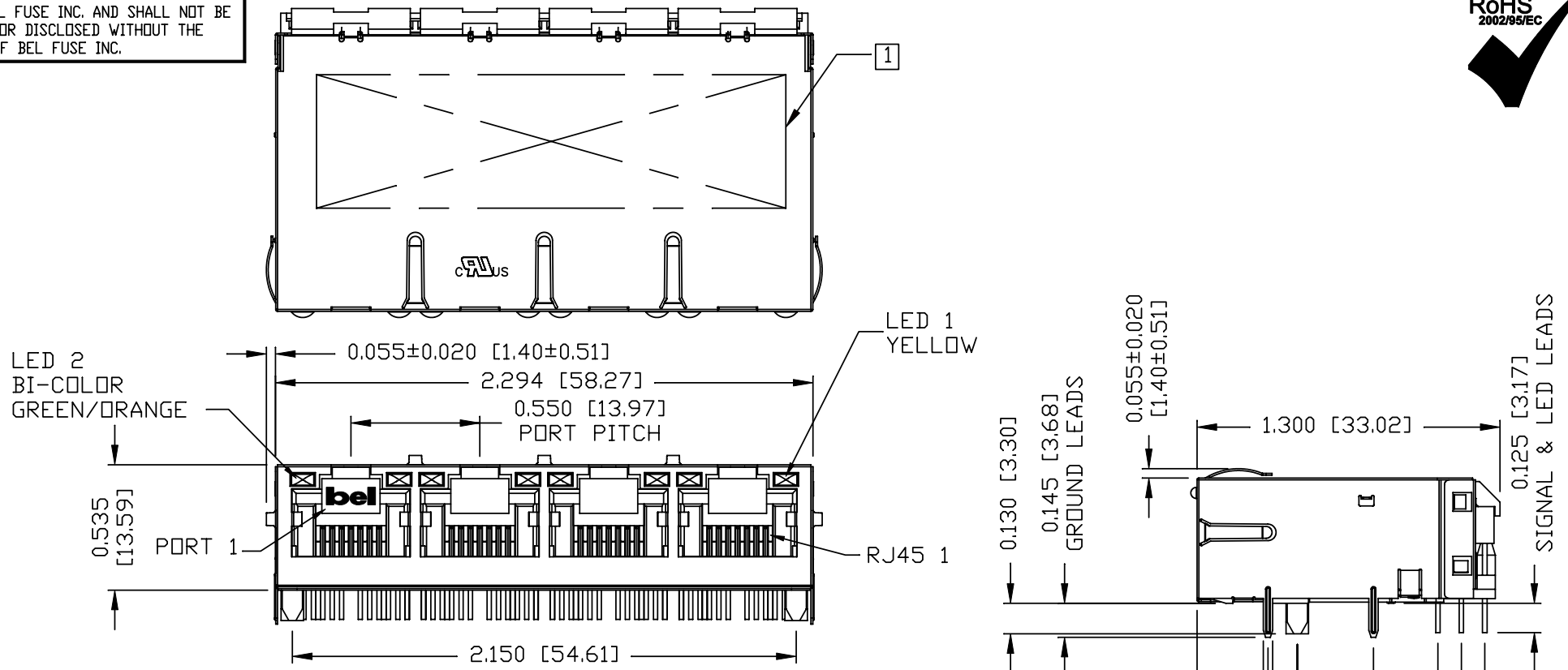

NOTES:

- PLASTIC HOUSING: THERMOPLASTIC PBT
FLAMMABILITY RATING UL 94V-0
- CONTACTS PLATING: 50 MICRO-INCH HARD GOLD PLATING
- PINS: TIN-COATED COPPER WIRE, DIA 0.018 INCH.
- METAL SHIELD: NICKEL PLATED ON COPPER ALLOY.
(ALL GROUND LEADS ARE SOLDER DIPPED)

[1] MARK PART WITH MFG LOGO, MFG NAME, PART NUMBER, DATE CODE.
AND "PATENTED" MARKING, THE PRODUCT IS PATENTED,
THE PATENTED NUMBER IS U.S. PAT. 5,736,910.
JACK CAVITY CONFORMS TO FCC RULES AND REGULATIONS.

USUL RECOGNIZED - FILE #E196366 AND E169987.
RoHS COMPLIANCE, PER EU DIRECTIVE 2002/95/EC.

ORIGINATED BY ZX HUANG	DATE 06-16-09	TITLE 1X4 gigabit MagJack® (12 cores, Tab Up) 0826-1X4T-23-F PATENTED	PART NO. / DRAWING NO. 08261X4T23-F	STANDARD DIM. TOL. IN INCH	[] METRIC DIM. AS REFERENCE		bel COMPONENTS FOR A CONNECTED PLANET	
DRAWN BY BL CHEN	DATE 06-16-09		FILE NAME 08261X4T23-F_F.DWG	.X .XX .XXX	±0.010	UNIT : INCH [mm] SCALE : N/A		REV. : F SIZE : A4 PAGE : 3

THE INFORMATION CONTAINED HEREIN IS CONSIDERED "PROPRIETARY" TO BEL FUSE INC. AND SHALL NOT BE COPIED, REPRODUCED OR DISCLOSED WITHOUT THE WRITTEN APPROVAL OF BEL FUSE INC.

RoHS
2002/95/EC



PORT ASSIGNMENT
(COMPONENT SIDE VIEW)

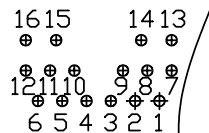
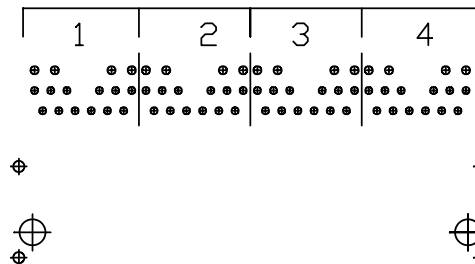

PIN-OUT INFORMATION
(COMPONENT SIDE VIEW)

12	TRCT1		
11	TRD1+		
10	TRD1-		
9	TRD4-		
8	TRD4+		
7	TRCT2		
6	TRCT2		
5	TRD2-		
4	TRD2+	16	ORG (-) GRN (+)
3	TRD3+	15	ORG (+) GRN (-)
2	TRD3-	14	YELLOW (+)
1	TRCT3	13	YELLOW (-)

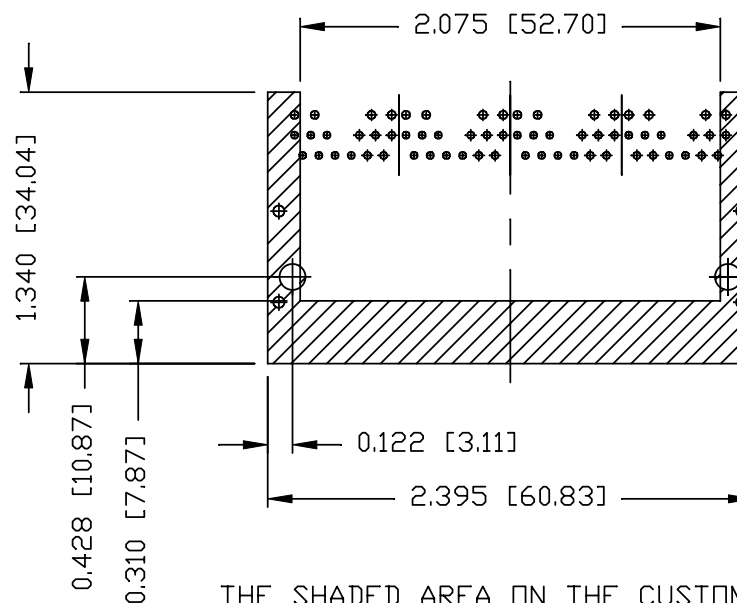

THE SHADED AREA ON THE CUSTOMER BOARD ARE RECOMMENDED TO BE CLEAR OFF ANY VIA HOLE OR COMPONENT PAD.

ORIGINATED BY	DATE	TITLE	PART NO. / DRAWING NO.	STANDARD DIM. TOL. IN INCH	[] METRIC DIM. AS REFERENCE	REV. :
ZX HUANG	06-16-09	1X4 gigabit MagJack® (12 cores, Tab Up) 0826-1X4T-23-F PATENTED	08261X4T23-F	.X	UNIT : INCH [mm]	F
DRAWN BY	DATE		FILE NAME	.XX	SCALE : N/A	SIZE : A4
BL CHEN	06-16-09		08261X4T23-F_F.DWG	.XXX ±0.004	SCALE : N/A	PAGE : 4



THE INFORMATION CONTAINED HEREIN IS CONSIDERED "PROPRIETARY" TO BEL FUSE INC. AND SHALL NOT BE COPIED, REPRODUCED OR DISCLOSED WITHOUT THE WRITTEN APPROVAL OF BEL FUSE INC.

RoHS
2002/95/EC

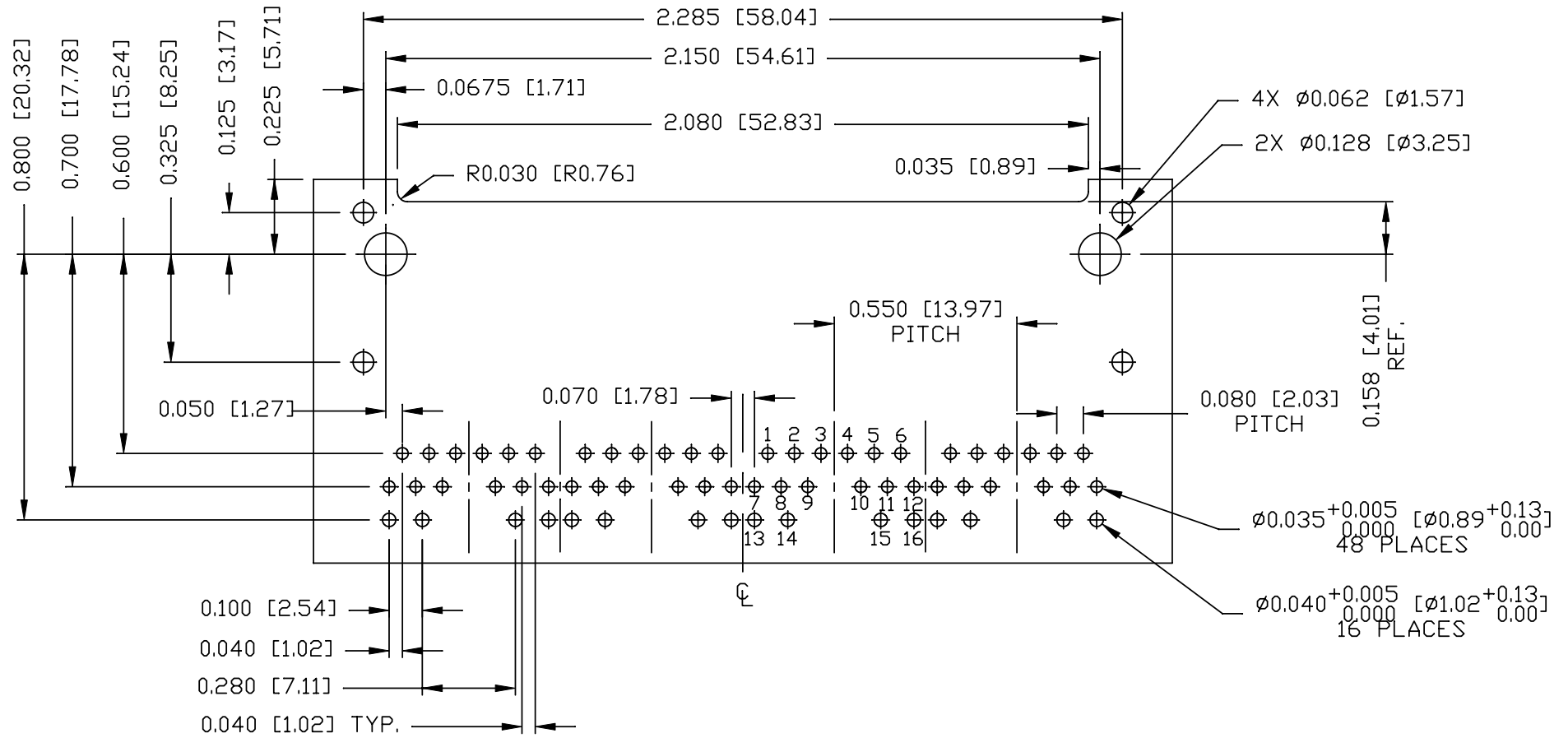

RECOMMENDED PCB FOOTPRINT

COMPONENT SIDE VIEW

ORIGINATED BY	DATE	TITLE 1X4 gigabit MagJack® (12 cores, Tab Up) 0826-1X4T-23-F PATENTED	PART NO. / DRAWING NO.	STANDARD DIM.	[] METRIC DIM. AS REFERENCE		
ZX HUANG	06-16-09		08261X4T23-F	TOL. IN INCH	UNIT : INCH [mm]	REV. : F	
DRAWN BY	DATE		FILE NAME	.X	SCALE : N/A	SIZE : A4	
BL CHEN	06-16-09		08261X4T23-F_F.DWG	.XX	±0.004	⊕	PAGE : 5
				.XXX			



THE INFORMATION CONTAINED HEREIN IS CONSIDERED "PROPRIETARY" TO BEL FUSE INC. AND SHALL NOT BE COPIED, REPRODUCED OR DISCLOSED WITHOUT THE WRITTEN APPROVAL OF BEL FUSE INC.

RoHS
2002/95/EC



SUGGESTED PANEL OPENING

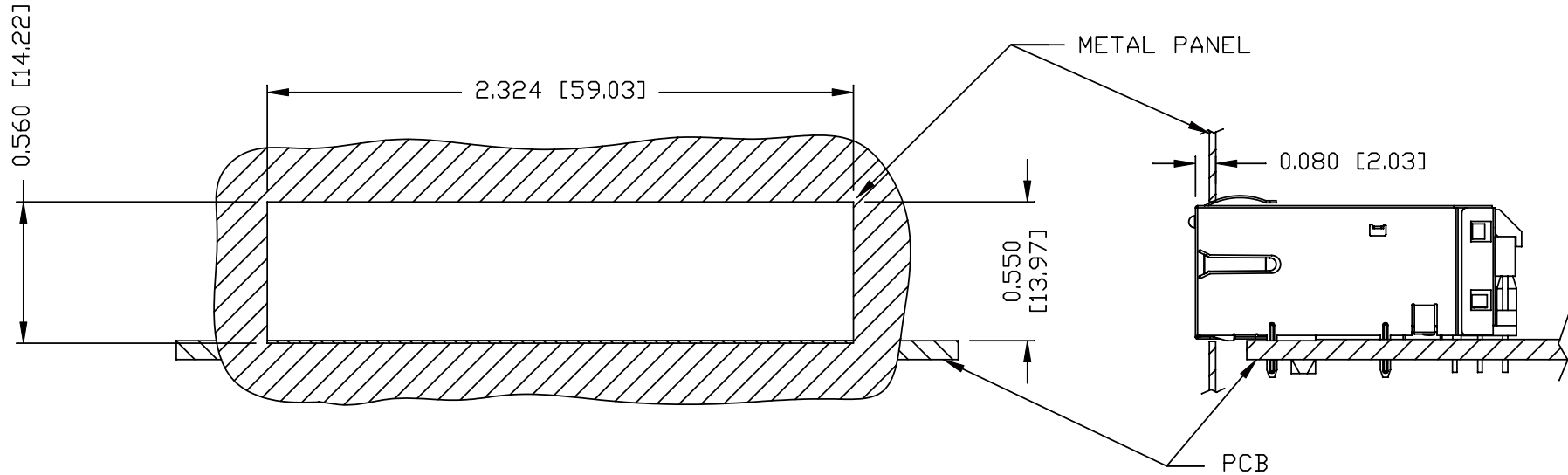

NOTES:

THE DISTANCE OF PANEL INSIDE SURFACE RELATIVE TO FRONT SURFACE OF PART IS ONLY A SUGGESTION. IN CASE THIS DISTANCE IS DIFFERENT, THE REQUIRED PANEL OPENING DIMENSIONS CHANGE ACCORDINGLY.

PACKING INFORMATION

PACKING TRAY : 0200-9999-B4 (TOP)
0200-9999-B5 (BOTTOM)

PACKING QUANTITY : 24 PCS FINISHED GOODS PER TRAY
10 TRAYS (240 PCS FINISHED GOODS) PER CARTON BOX

NOTE : CARDBOARDS ARE PLACED BETWEEN LAYERS OF PACKING TRAY INSIDE CARTON BOX
(INCLUDE THE UPPERMOST AND LOWERMOST TRAY)

ORIGINATED BY ZX HUANG	DATE 06-16-09	TITLE 1X4 gigabit MagJack® (12 cores, Tab Up)	PART NO. / DRAWING NO. 08261X4T23-F	STANDARD DIM. TOL. IN INCH		[] METRIC DIM. AS REFERENCE		bel
				.X		UNIT : INCH [mm]	REV. : F	
DRAWN BY BL CHEN	DATE 06-16-09	0826-1X4T-23-F PATENTED	FILE NAME 08261X4T23-F_F.DWG	.XX		SCALE : N/A	SIZE : A4	COMPONENTS FOR A CONNECTED PLANET
				.XXX	±0.004	⊕	PAGE : 6	