

ITEM #	PART #	QTY	DESCRIPTION
1	TJS-102-9	1	JACK ASSEMBLY
2	TP-102-20	1	CRIMP SLEEVE
3	TJ-102-6BL	1	SHELL

C TJ-102BL

NOTES:
 1) EACH PART SHALL BE MARKED WITH U-94A/U & M9177/3-1
 2) CRIMPING TOOLS: USE M22520/5-01 HAND TOOL W/CRIMP DIE M22520/5-29, M22520/5-35 OR M22520/5-55
 3) MATING CONNECTORS M9177/1-1, & M9177/2-1

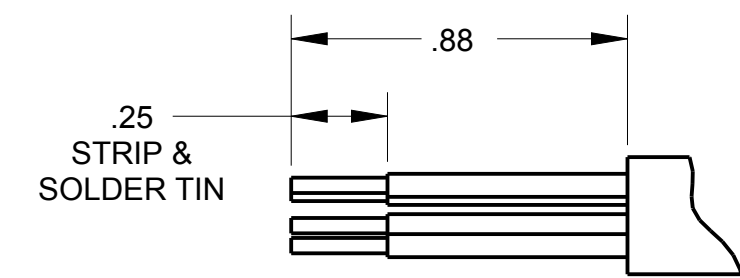
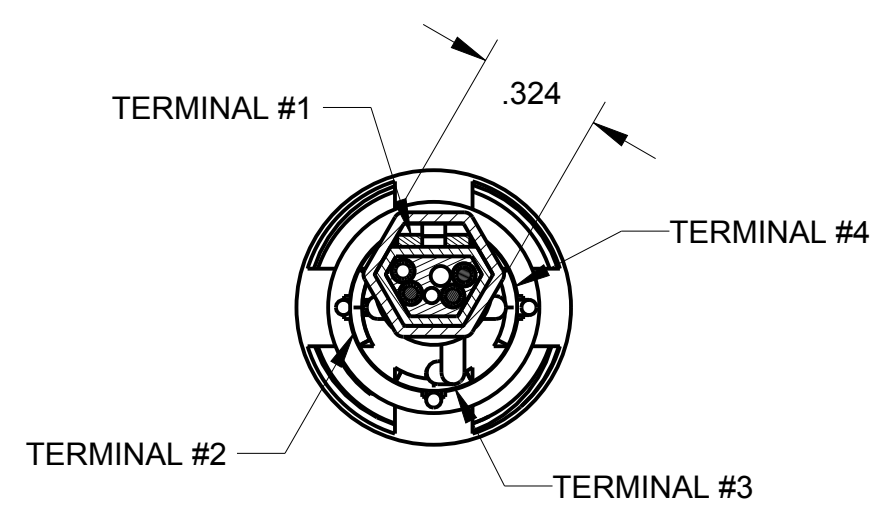
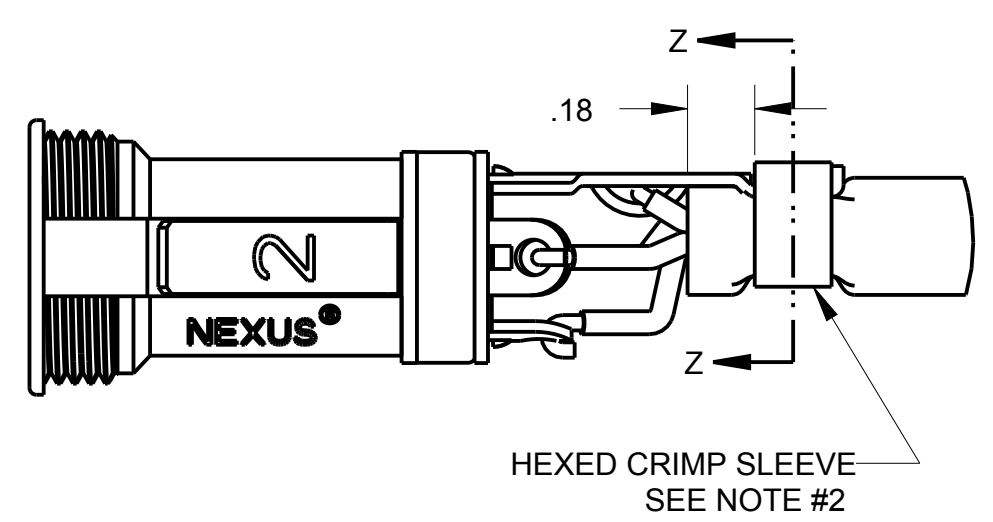
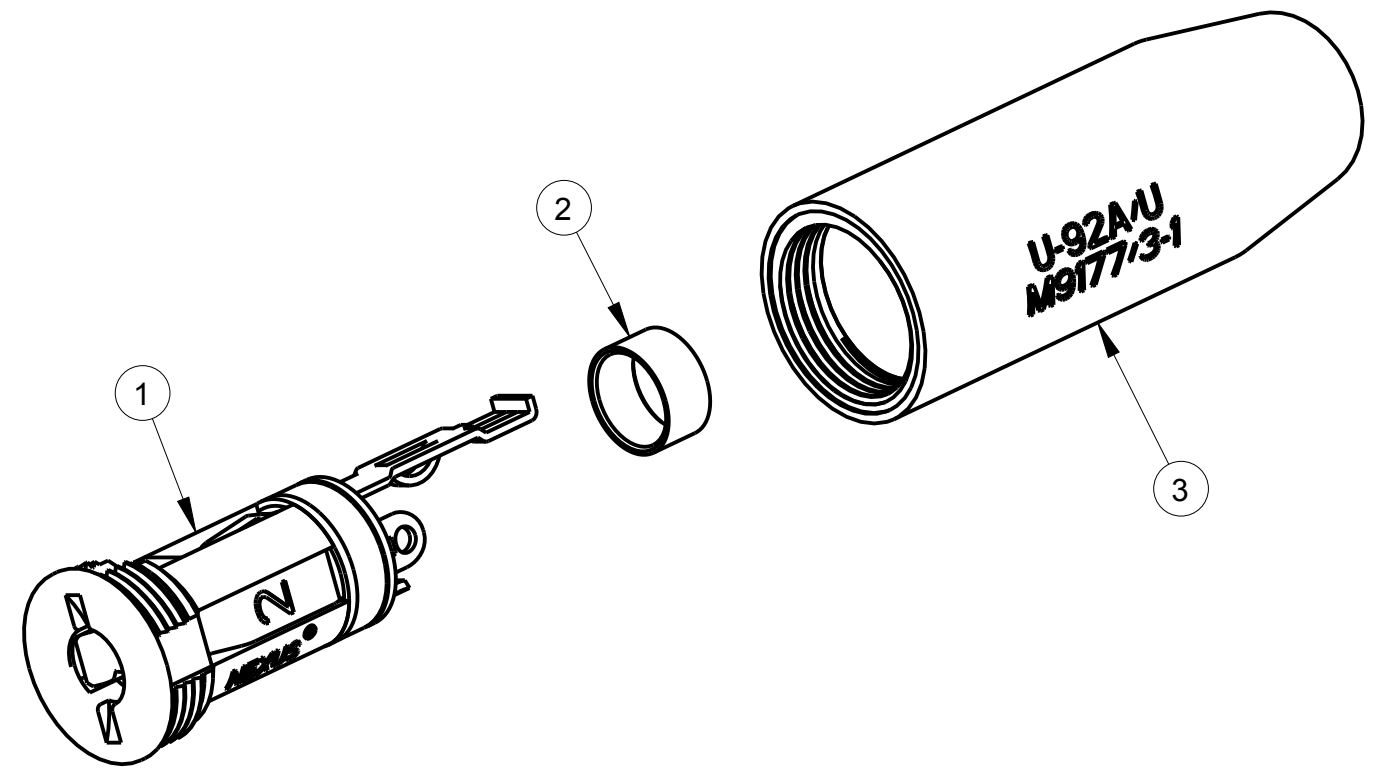
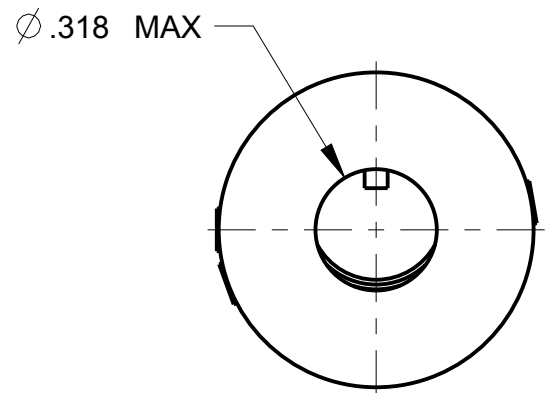
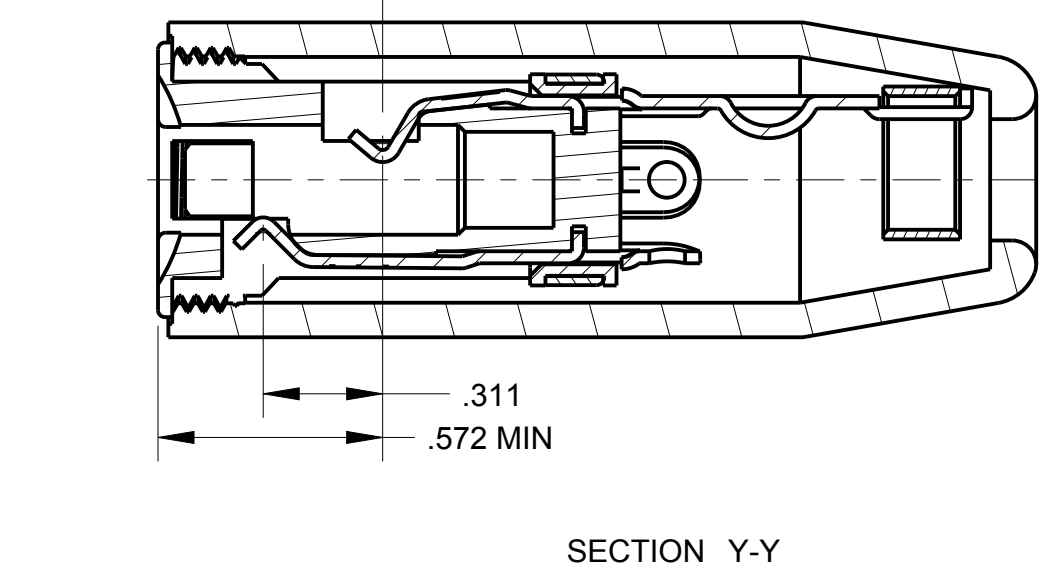
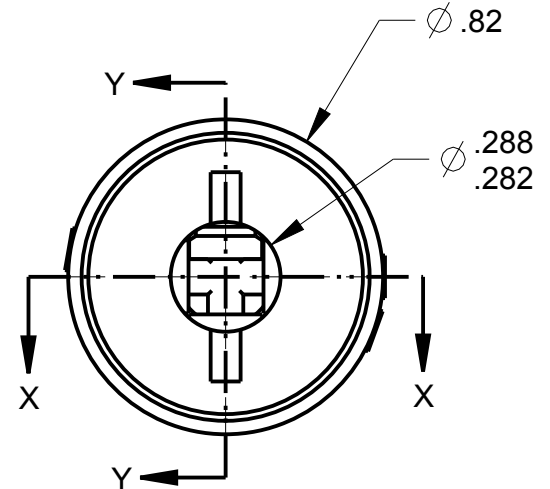
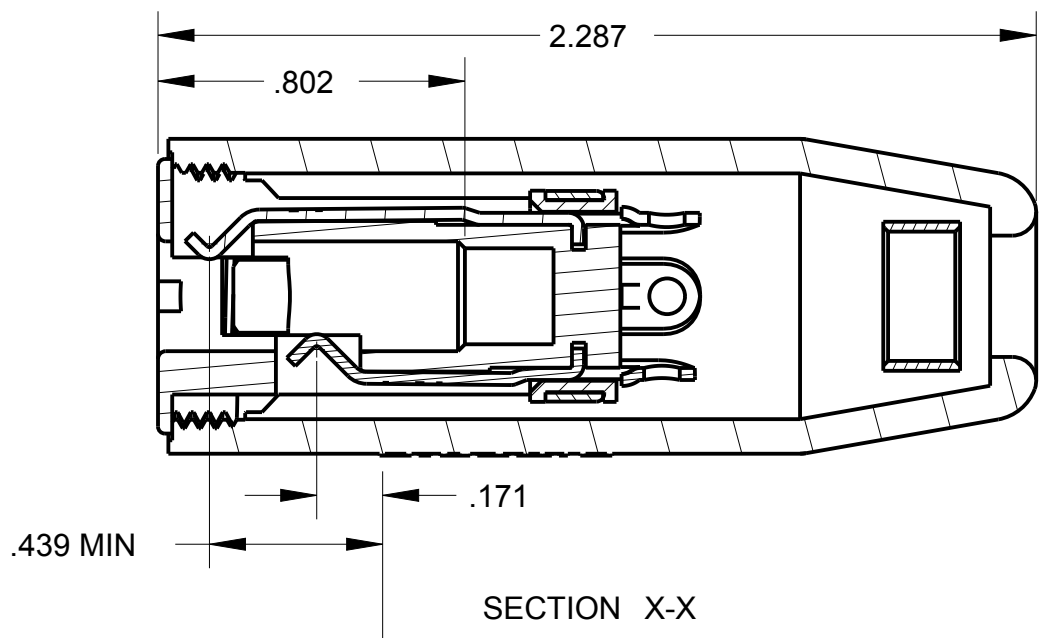

RECOMMENDED CABLE:
 WM-14/U (4-COND)
 FOR USE WITH U-94A/U

THIS DOCUMENT CONTAINS PROPRIETARY INFORMATION OF NEXUS, INCORPORATED AND SUCH INFORMATION MAY NOT BE DISCLOSED TO OTHERS FOR ANY PURPOSE OR USED FOR ANY PURPOSE WITHOUT THE WRITTEN CONSENT OF NEXUS.

DWN. BY		HR	DATE		5/11/15	MATERIAL	
CHECKED BY			DATE			FINISH	
APPR. BY			DATE			WEIGHT	SCALE = 4.00 :1
UNLESS OTHERWISE SPECIFIED DIMENSIONS ARE IN INCHES & OR (mm)						TITLE	
TOLERANCES:						TELEPHONE JACK	
DECIMAL:						NEXUS	
±.XX(X.X) ±.XXX(X.XX) ±.XXXX(X.XXX)						STAMFORD, CONN	
±.0X(0.X) ±.00X(0.0X) ±.000X(0.0XX)						SIZE	DWG. NO.
FRACTION: ±X/XX ±X/XX						C	TJ-102BL
ANGLES: ±X° ±X°						DO NOT SCALE DWG.	SHEET 1 OF 1

A	NEW RELEASE	222	5/11/2015	HR
LET.	REVISION	CN #	DATE	CHK