

SPECIFICATIONS

PARAMETERS	VALUES	UNITS
RESONANT FREQUENCY	7,000 ± 600	Hz
RESONANT IMPEDANCE (MAX)	1000	Ohm
MAX INPUT VOLTAGE	15	Vp-p
CAPACITANCE @ 1KHZ	10,000 ± 30%	pF
PLATE MATERIAL	BRASS	-
OPERATING TEMPERATURE	-20 ~ +80	°C
STORAGE TEMPERATURE	-20 ~ +80	°C

THIS DOCUMENT CONTAINS DATA PROPRIETARY TO PROJECTS UNLIMITED, INC. ANY USE OR REPRODUCTION, IN ANY FORM, WITHOUT PRIOR WRITTEN PERMISSION OF PROJECTS UNLIMITED, INC. IS PROHIBITED.
©2003, Projects Unlimited Inc.

REVISION HISTORY

LTR	DESCRIPTION	DATE	APPROVED
-	RELEASED FROM ENGINEERING	4/13/2013	

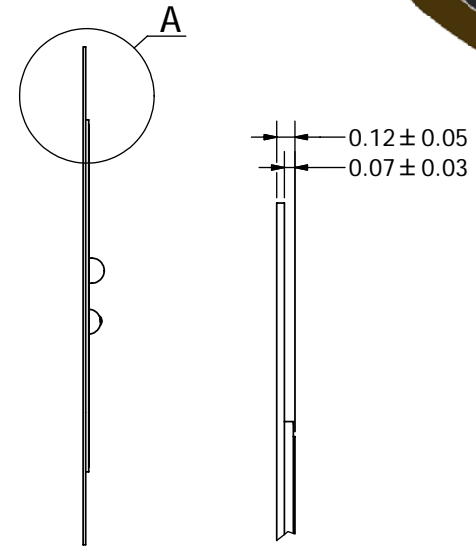
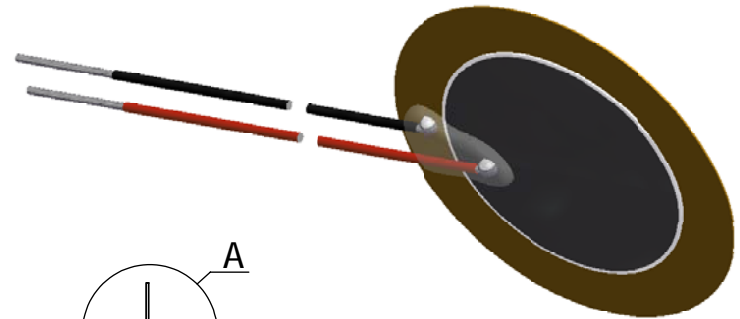
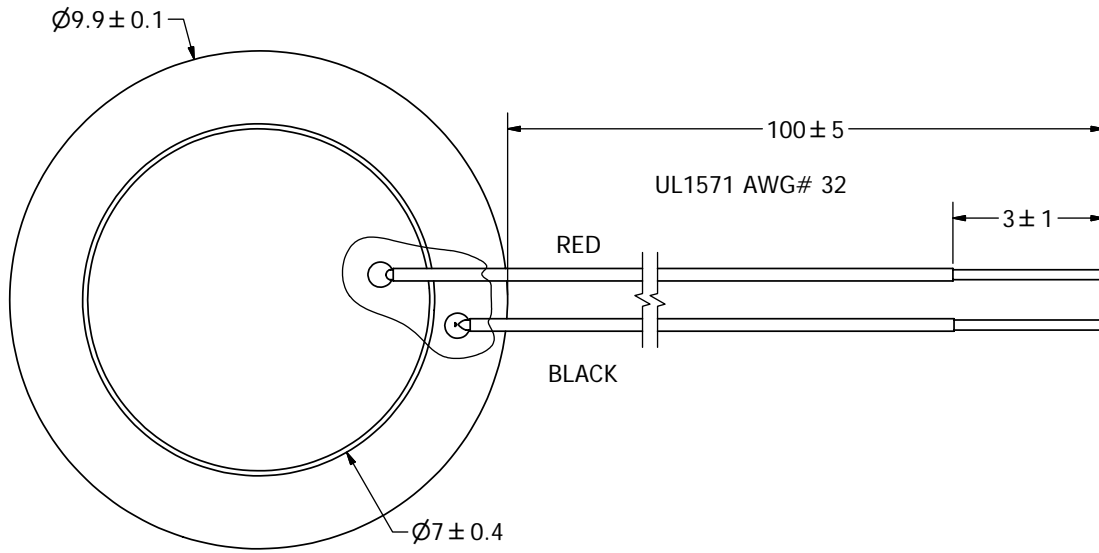

A (30 : 1)

NOTES:

1. ALL DIMENSIONS ARE IN MILLIMETERS.
2. SPECIFICATIONS SUBJECT TO CHANGE OR WITHDRAWAL WITHOUT NOTICE.
3. THIS PART IS RoHS 2011/65/EU COMPLIANT.

UNLESS OTHERWISE SPECIFIED: DIMENSIONS ARE IN MILLIMETERS, TOLERANCES ARE ±0.5 AND ANGLES ARE ±3°.	SIZE A3	Designed by	Date	Checked by	Date	Approved by	Date	Drawn Date
		J.D.	4/13/2013	C.W.	4/22/2013	B.R.	4/22/2013	4/13/2013
		 AB1070B-LW100-R						Edition
AB1070B-LW100-R.idw		Bender				-	1 / 1	