

Φ .006 @ V Z Y S
TYP AT POST TIPS

- 1 CONTACT AREA PLATED WITH .000030 MIN GOLD, SOLDER LEADS PLATED WITH .000150 TIN LEAD, ALL OVER .000050 NICKEL
- 2 POINT OF MEASUREMENT FOR GOLD THICKNESS
- 3 CIRCUIT IDENTIFICATION FEATURE OMITTED ON 8,10,12,& 14 POSITION HEADER ASSEMBLIES
- 4 DIMENSION APPLIES AT BASE OF SHROUD
- 5 THE NOTED DIMENSIONS APPLY AT THE INTERSECTION OF THE POST AND HOUSING
- 6 CONTACT AREA PLATED WITH .000030 MIN GOLD, SOLDER LEADS PLATED WITH .000150 TIN, ALL OVER .000050 NICKEL
- 7 FINISH: .000001 MIN GOLD ON GOLD PLATED AREA. .000150-.000250 MATTE TIN-LEAD ON TIN PLATED AREA. UNDER PLATING TO BE .000050-.000100 NICKEL ON ENTIRE CONTACT.
- 8 FINISH: .000001 MIN GOLD ON GOLD PLATED AREA. .000150-.000250 MATTE TIN ON TIN PLATED AREA. UNDER PLATING TO BE .000050-.000100 NICKEL ON ENTIRE CONTACT.
- 9 PRELIMINARY - NOT FOR PRODUCTION
- 10 OBSOLETE
- 11 OBSOLETE PARTS: OBSOLETE CIS STREAMLINING PER D.RENAUD/D.SINISI

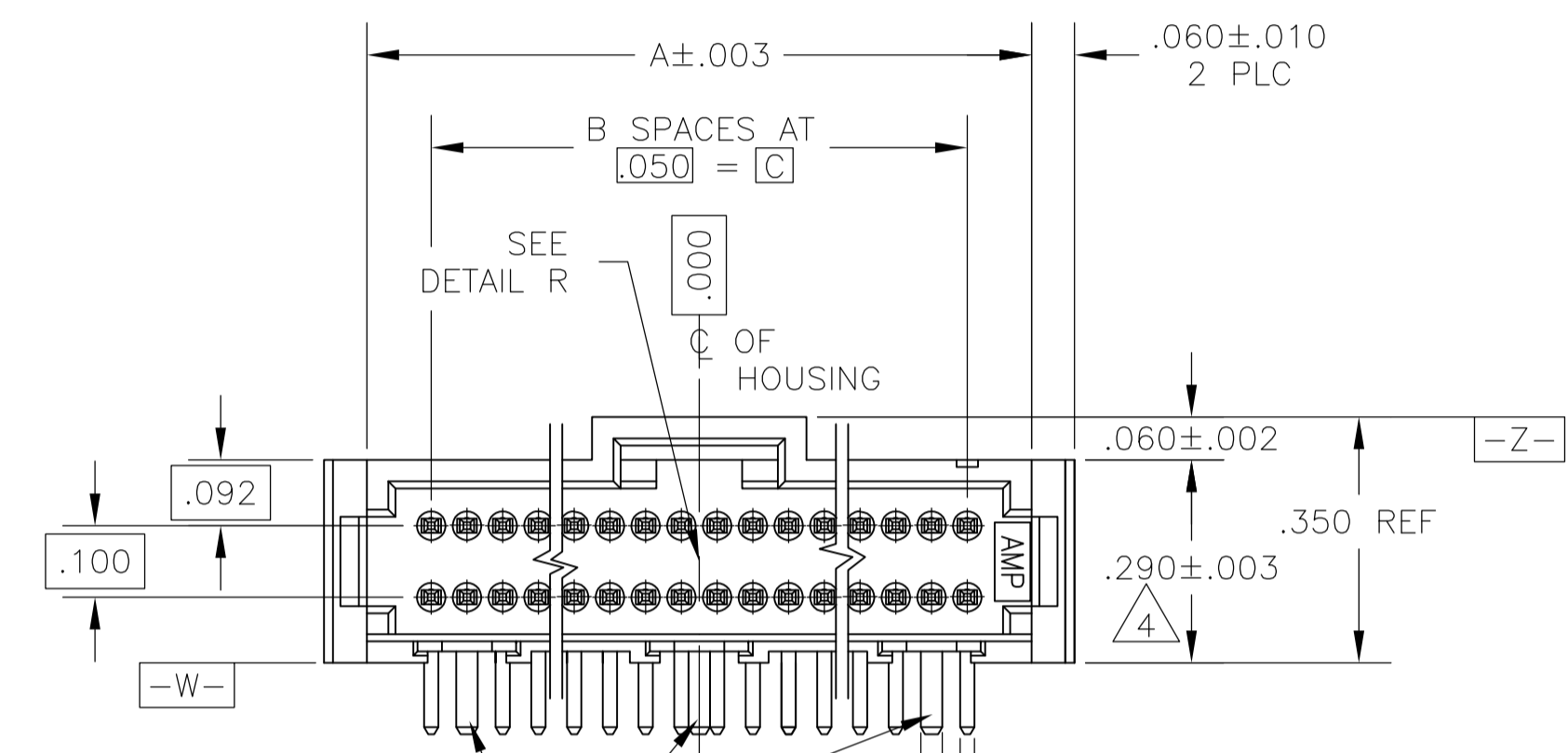

HOLD DOWN FEATURES LOCATED AS SHOWN FOR 16 THRU 100 POSN ASSEMBLIES (SEE TABLE)

HOLD DOWN FEATURES LOCATED AS SHOWN FOR 8 THRU 14 & 60 THRU 100 POSN ASSEMBLIES (SEE TABLE)

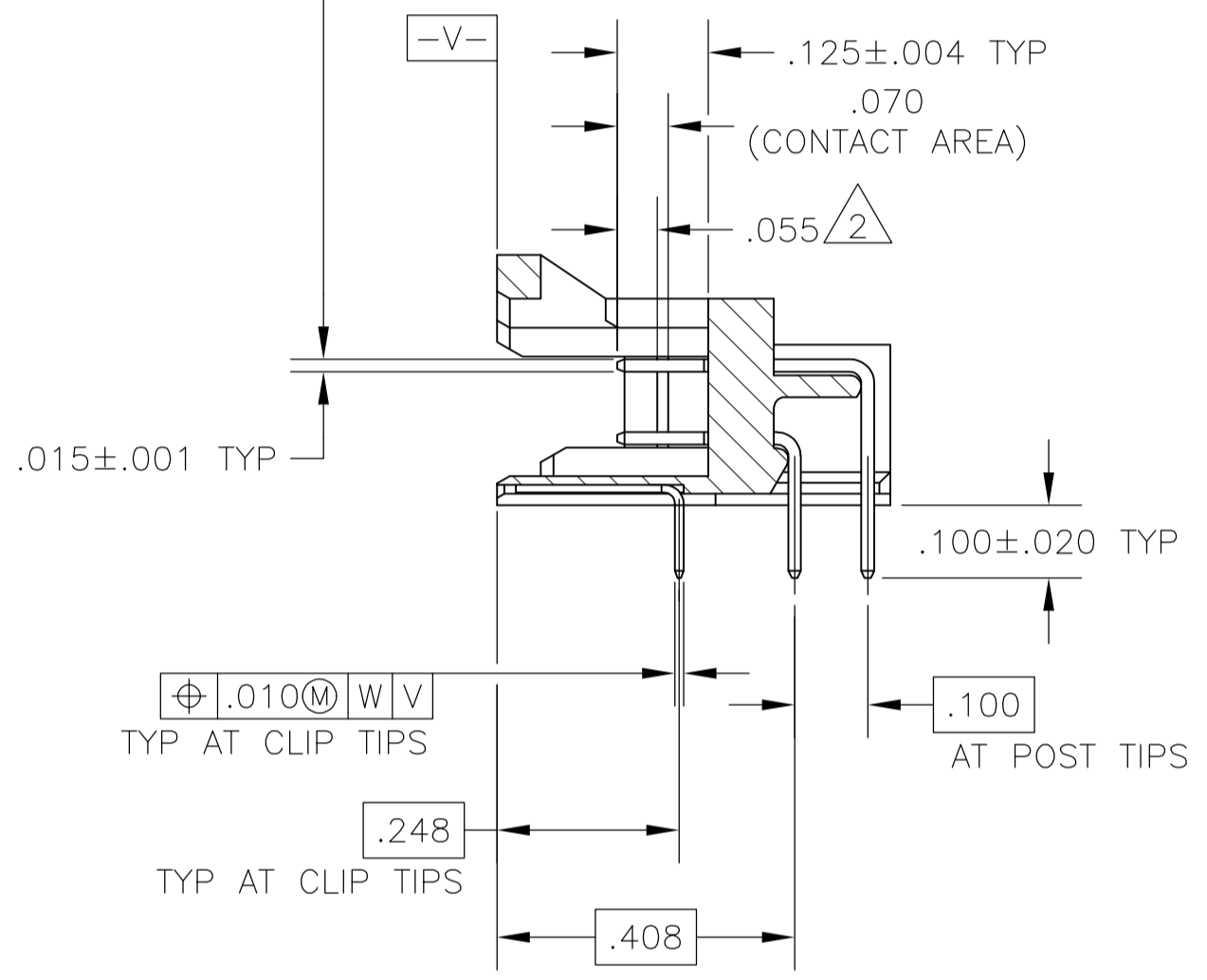

Φ .010 @ W V
TYP AT CLIP TIPS

Φ .010 @ W V Y S
TYP AT CLIP TIPS

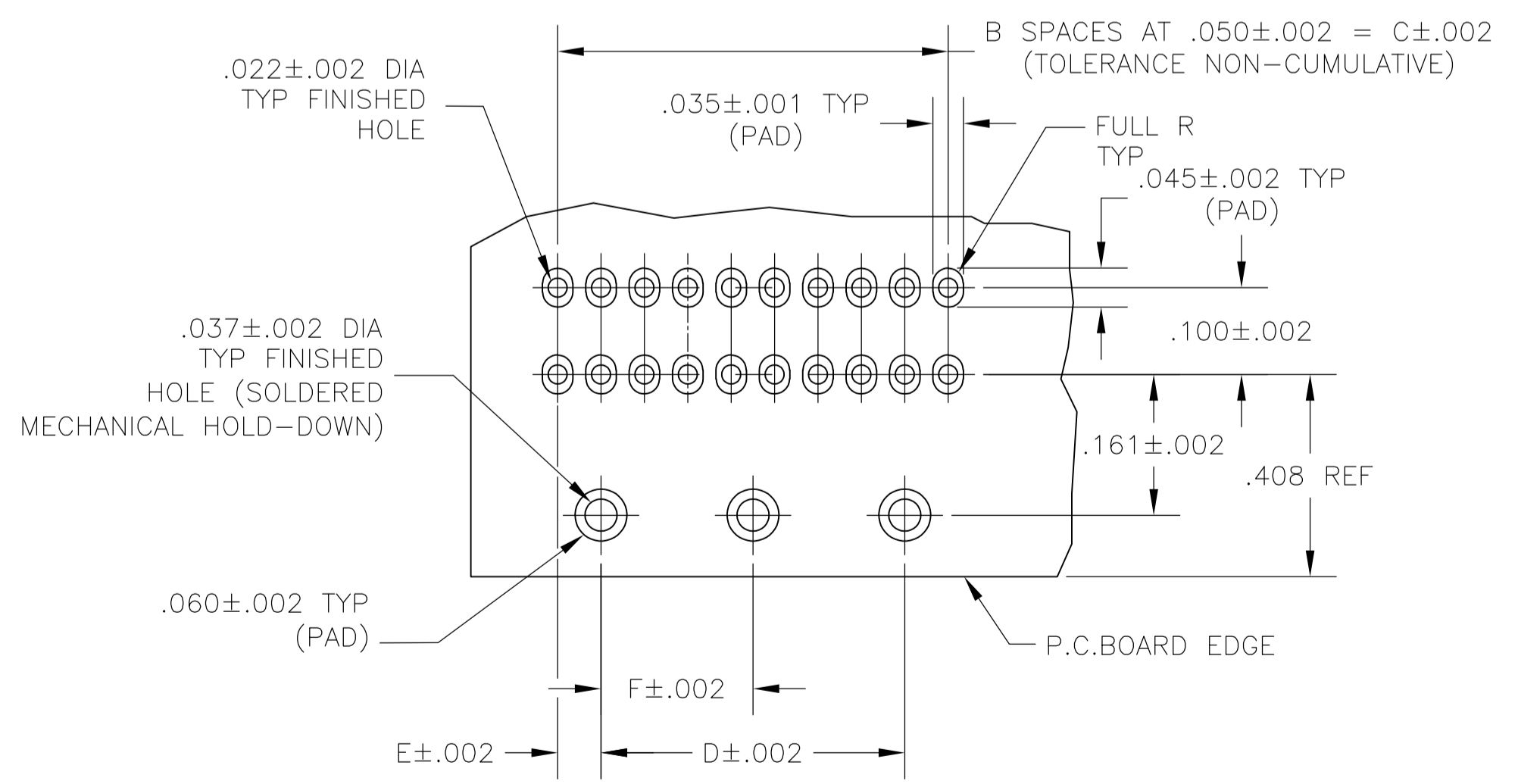

RECOMMENDED HOLE PATTERN

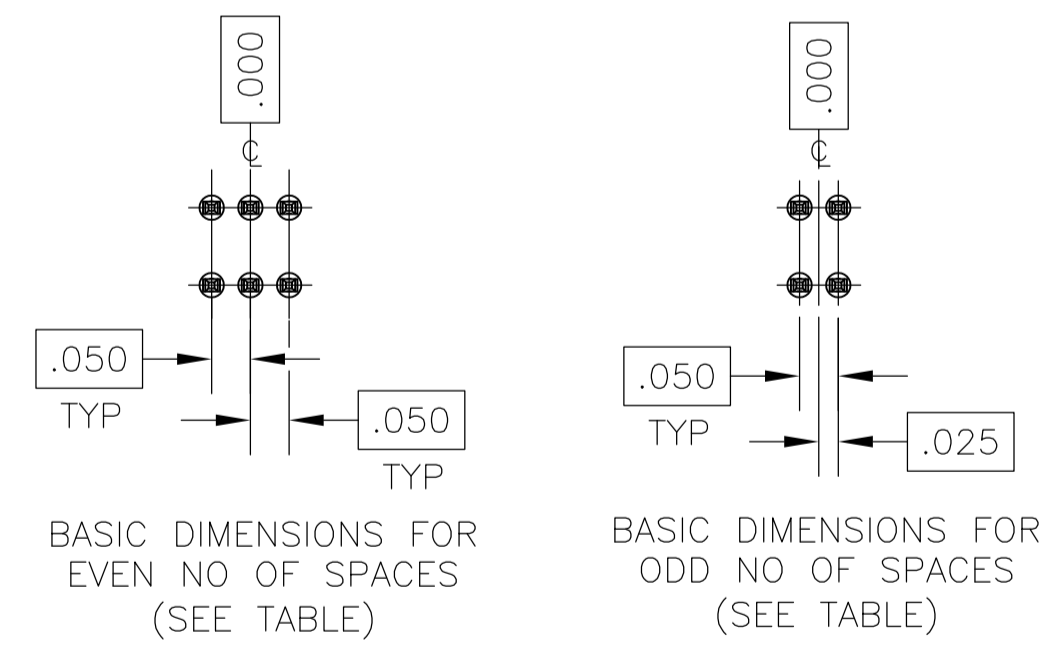

DETAIL R

7	.775	.050	1.550	1.650	33	1.830	68	3-104069-8
	1.175	.050	2.350	2.450	49	2.630	100	3-104069-7
	.825	.050	1.650	1.750	35	1.930	72	3-104069-6
	-	.050	.950	1.050	21	1.230	44	3-104069-5
	-	.050	.700	.800	16	.980	34	3-104069-4
	-	.050	.500	.600	12	.780	26	3-104069-3
	-	.050	.450	.550	11	.730	24	3-104069-2
	-	.050	.250	.350	7	.530	16	3-104069-1
	-	.150	-	.300	6	.480	14	3-104069-0
	-	.125	-	.250	5	.430	12	2-104069-9
	-	.075	-	.150	3	.330	8	2-104069-8
	.675	.050	1.350	1.450	29	1.630	60	2-104069-7
	-	.050	.850	.950	19	1.130	40	2-104069-6
	-	.050	.600	.700	14	.880	30	2-104069-5
	-	.100	-	.200	4	.380	10	2-104069-4
	11	.925	.050	1.850	1.950	39	2.130	80
-		.050	1.100	1.200	24	1.380	50	2-104069-2
-		.050	.350	.450	9	.630	20	2-104069-1
.775		.050	1.550	1.650	33	1.830	68	1-104069-8
1.175		.050	2.350	2.450	49	2.630	100	1-104069-7
.825		.050	1.650	1.750	35	1.930	72	1-104069-6
-		.050	.950	1.050	21	1.230	44	1-104069-5
-		.050	.700	.800	16	.980	34	1-104069-4
-		.050	.500	.600	12	.780	26	1-104069-3
-		.050	.450	.550	11	.730	24	1-104069-2
-		.050	.250	.350	7	.530	16	1-104069-1
-		.150	-	.300	6	.480	14	1-104069-0
-		.125	-	.250	5	.430	12	104069-9
-		.075	-	.150	3	.330	8	104069-8
.675		.050	1.350	1.450	29	1.630	60	104069-7
-		.050	.850	.950	19	1.130	40	104069-6
-	.050	.600	.700	14	.880	30	104069-5	
-	.100	-	.200	4	.380	10	104069-4	
.925	.050	1.850	1.950	39	2.130	80	104069-3	
-	.050	1.100	1.200	24	1.380	50	104069-2	
-	.050	.350	.450	9	.630	20	104069-1	

FINISH	F	E	D	C	B	A	NO OF POSN	PART NUMBER
--------	---	---	---	---	---	---	------------	-------------

THIS DRAWING IS A CONTROLLED DOCUMENT. **STE** TE Connectivity

DIMENSIONS: INCHES	TOLERANCES UNLESS OTHERWISE SPECIFIED:	DIN D. CLOUSER 10-3-88	APVD T. ZOLA 10-3-88
0 PLC ± -	1 PLC ± -	NAME T. ZOLA	PRODUCT SPEC 108-1093
2 PLC ± -	3 PLC ± .005	APPLICATION SPEC 114-25031	SIZE A1
4 PLC ± -	ANGLES ± -	WEIGHT -	CAGE CODE 00779
MATERIAL HOUSING:THERMOPLASTIC COLOR:BLACK CONTACT: COPPER ALLOY	FINISH SEE TABLE	CUSTOMER DRAWING	SCALE 4:1 SHEET 1 OF 2 REV AA

LOC		DIST		REVISIONS				
P	LTR	DESCRIPTION	DATE	DN	APVD			
-	-	SEE SHEET 1	-	-	-			

8	.775	.050	1.550	1.650	33	1.830	68	8-104069-8
	1.175	.050	2.350	2.450	49	2.630	100	8-104069-7
	.825	.050	1.650	1.750	35	1.930	72	8-104069-6
	-	.050	.950	1.050	21	1.230	44	8-104069-5
	-	.050	.700	.800	16	.980	34	8-104069-4
	-	.050	.500	.600	12	.780	26	8-104069-3
	-	.050	.450	.550	11	.730	24	8-104069-2
	-	.050	.250	.350	7	.530	16	8-104069-1
	-	.150	-	.300	6	.480	14	8-104069-0
	-	.125	-	.250	5	.430	12	7-104069-9
	-	.075	-	.150	3	.330	8	7-104069-8
	.675	.050	1.350	1.450	29	1.630	60	7-104069-7
	-	.050	.850	.950	19	1.130	40	7-104069-6
	-	.050	.600	.700	14	.880	30	7-104069-5
	-	.100	-	.200	4	.380	10	7-104069-4
	.925	.050	1.850	1.950	39	2.130	80	7-104069-3
	-	.050	1.100	1.200	24	1.380	50	7-104069-2
	-	.050	.350	.450	9	.630	20	7-104069-1
6	.775	.050	1.550	1.650	33	1.830	68	6-104069-8
	1.175	.050	2.350	2.450	49	2.630	100	6-104069-7
	.825	.050	1.650	1.750	35	1.930	72	6-104069-6
	-	.050	.950	1.050	21	1.230	44	6-104069-5
	-	.050	.700	.800	16	.980	34	6-104069-4
	-	.050	.500	.600	12	.780	26	6-104069-3
	-	.050	.450	.550	11	.730	24	6-104069-2
	-	.050	.250	.350	7	.530	16	6-104069-1
	-	.150	-	.300	6	.480	14	6-104069-0
	-	.125	-	.250	5	.430	12	5-104069-9
	-	.075	-	.150	3	.330	8	5-104069-8
	.675	.050	1.350	1.450	29	1.630	60	5-104069-7
	-	.050	.850	.950	19	1.130	40	5-104069-6
	-	.050	.600	.700	14	.880	30	5-104069-5
	-	.100	-	.200	4	.380	10	5-104069-4
	.925	.050	1.850	1.950	39	2.130	80	5-104069-3
	-	.050	1.100	1.200	24	1.380	50	5-104069-2
	-	.050	.350	.450	9	.630	20	5-104069-1
FINISH	F	E	D	C	B	A	NO OF POSN	PART NUMBER

THIS DRAWING IS A CONTROLLED DOCUMENT.		D. CLOUSER 10-3-88		 TE Connectivity	
DIMENSIONS: INCHES		TOLERANCES UNLESS OTHERWISE SPECIFIED:			
0 PLC ± - 1 PLC ± - 2 PLC ± - 3 PLC ± .005 4 PLC ± - ANGLES ± -		D. CLOUSER 10-3-88 T. ZOLA 10-3-88 NAME: T. ZOLA PRODUCT SPEC: 108-1093 APPLICATION SPEC: 114-25031		HEADER ASSEMBLY, RIGHT ANGLE, DOUBLE ROW, W/SIDE & END LATCHES, AMPMODU System 50	
MATERIAL		FINISH SEE TABLE		WEIGHT: - SIZE: A1 CASE CODE: 00779 DRAWING NO: 104069 RESTRICTED TO: -	
CUSTOMER DRAWING				SCALE: 4:1 SHEET 2 OF 2 REV AA	