

THIS DOCUMENT IS THE PROPERTY OF KEYSTONE ELECTRONICS CORP. AND SHALL NOT BE REPRODUCED, DISTRIBUTED OR USED AS A BASIS FOR MANUFACTURE WITHOUT PRIOR WRITTEN PERMISSION FROM KEYSTONE ELECTRONICS CORP.

RECOMMENDED SPACING FOR PC LUGS

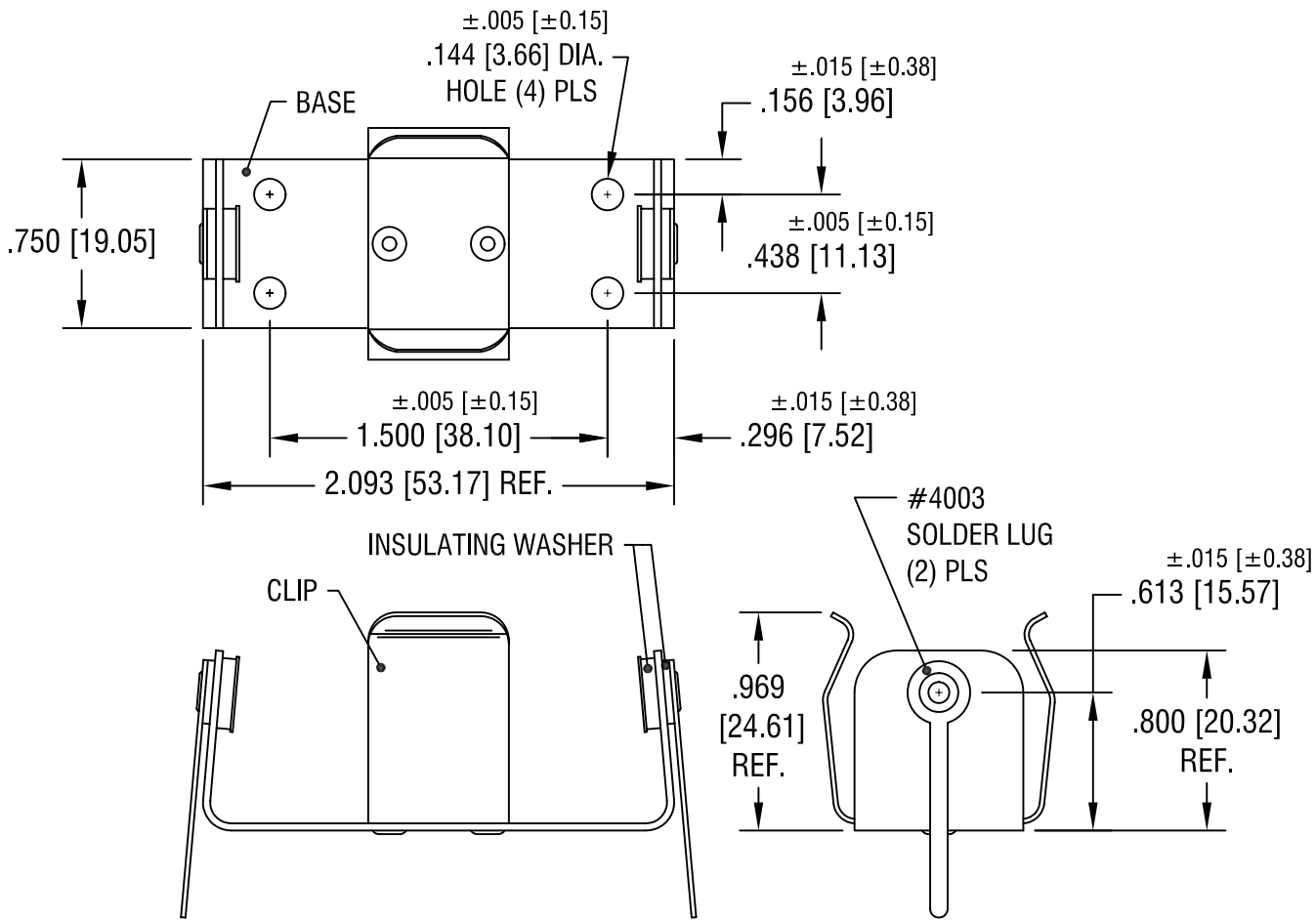
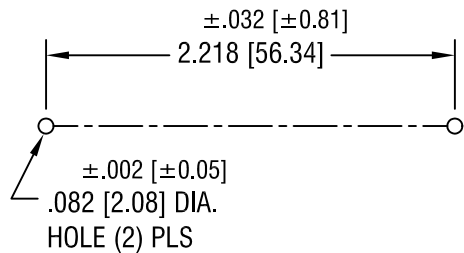

NOTES:

- 1. BASE: MAT'L - .032 [.81] TH'K ALUMINUM
- CLIP: MAT'L - .020 [.50] TH'K ALUMINUM
- SOLDER LUG: MAT'L - BRASS
- FINISH - TIN PLATE

12.2.04	CHANGE AS PER ECN 04-164	B
DATE	DESCRIPTION	REV.

KEYSTONE ELECTRONICS CORP.			
ASTORIA, N.Y. 11105-2017			
PART NAME			
BATTERY HOLDER (1) 'C'			
MATERIAL			
AS NOTED			
FINISH		DRN BY	DATE
AS NOTED		BOONE	1.12.82
		APPD	SCALE
		LN	1.2X
TOLERANCES	INCH	MM	CODE
DECIMAL	±.010	[± 0.25]	C
ANGULAR	± 1°		
UNLESS OTHERWISE SPECIFIED			DWG NO.
			2224