

UNCONTROLLED DOCUMENT

PART NUMBER		REV.
SSF-LXH109SYSUGW		A
REV.	E.C.N. NUMBER AND REVISION COMMENTS	DATE
A	E.C.N. #10991.	5.15.03

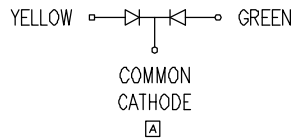
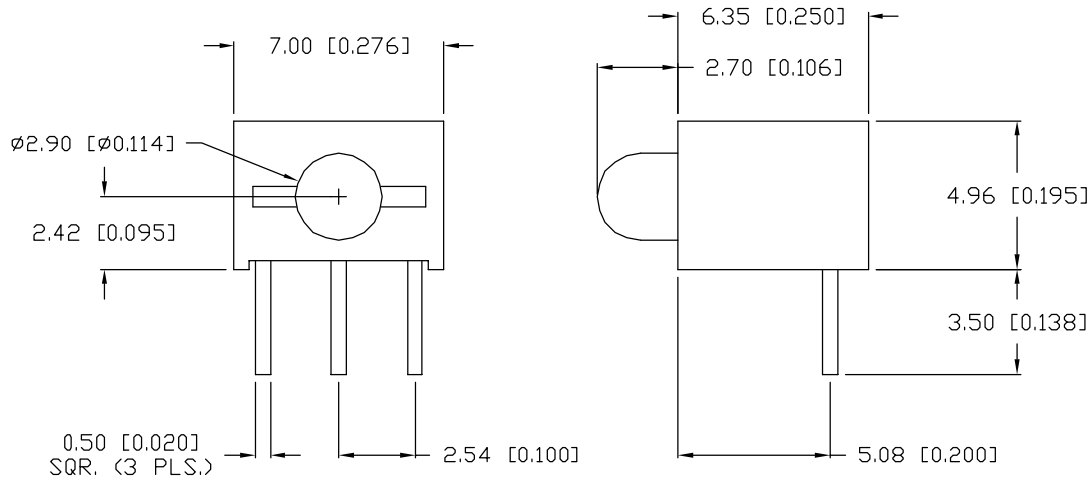

ELECTRO-OPTICAL CHARACTERISTICS $T_A=25^\circ\text{C}$ $I_f=20\text{mA}$

PARAMETER	MIN	TYP	MAX	UNITS	TEST COND
PEAK WAVELENGTH		590 (YELLOW)		nm	
		574 (GREEN)		nm	
FORWARD VOLTAGE (Y/G)		2.0/2.2	2.5/2.6	V_f	
REVERSE VOLTAGE	5.0			V_r	$I_r=100\mu\text{A}$
AXIAL INTENSITY (Y/G)		250/80		mcd	$I_f=20\text{mA}$
VIEWING ANGLE		60		2x theta	
EMITTED COLOR:	YELLOW/GREEN				
EPOXY LENS FINISH:	MILKY WHITE DIFFUSED				

LIMITS OF SAFE OPERATION AT 25°C

PARAMETER	COLORS	MAX	UNITS
PEAK FORWARD CURRENT*		150	mA
STEADY CURRENT	(Y/G)	30/25	mA
POWER DISSIPATION		105	mW
DERATE FROM 25°C		-1.2	mW/ $^\circ\text{C}$
OPERATING, STORAGE TEMP.		-40 TO +85	$^\circ\text{C}$
SOLDERING TEMP.		+260	$^\circ\text{C}$
2.0mm FROM BODY			3 SEC. MAX

* $t < 10\mu\text{s}$

*UNLESS OTHERWISE SPECIFIED TOLERANCES PER DECIMAL PRECISION ARE: X=±1 (±0.039), X.X=±0.5 (±0.020), X.XX=±0.25 (±0.010), X.XXX=±0.127 (±0.005). LEAD SIZE=±0.05 (±0.002), LEAD LENGTH=±0.75 (±0.030). MIN.=⁺DECIMAL PRECISION MAX.=⁺0.00
-DECIMAL PRECISION

UNCONTROLLED DOCUMENT

REV.	PART NUMBER
A	SSF-LXH109SYSUGW
T-3mm 3 LEADED BI-COLOR FAULT INDICATOR, 590nm SUPER YELLOW/574nm SUPER ULTRA GREEN, MILKY WHITE DIFFUSED LENS.	

CONFIDENTIAL INFORMATION
THE INFORMATION CONTAINED IN THIS DOCUMENT IS THE PROPERTY OF LUMEX INC. EXCEPT AS SPECIFICALLY AUTHORIZED IN WRITING BY LUMEX INC., THE HOLDER OF THIS DOCUMENT SHALL KEEP ALL INFORMATION CONTAINED HEREIN CONFIDENTIAL AND SHALL PROTECT SAME IN WHOLE OR IN PART FROM DISCLOSURE AND DISSEMINATION TO ALL THIRD PARTIES.

RELIABILITY NOTE
OUR MANY YEARS OF EXPERIENCE DATA ACCUMULATION INDICATE THAT SOLDER HEAT IS A MAJOR CAUSE OF EARLY AND FUTURE FAILURE. PLEASE PAY ATTENTION TO YOUR SOLDERING PROCESS.

		290 E. HELEN ROAD PALATINE, IL 60067-6976 PHONE: +1.847.359.2790 US WEB: www.lumex.com TW WEB: www.lumex.com.tw
DRAWN BY:	CHECKED BY:	APPROVED BY:
CT		
DATE:	PAGE:	SCALE:
4.1.02	1 OF 1	N/A