

## Product Specification

---

### Ultra-High Power Photodetector

---

### VPDV2120

#### PRODUCT FEATURES

- Operational up to 20 GHz
- $\geq 22$  dBm RF output power @ 10 GHz
- High Linearity ( $> 30$  dBm OIP3 @ 10GHz)
- No cooling required



#### APPLICATIONS

- Microwave Photonics
- Analog Photonic links
- Radio-over-fiber

The VPDV2120 is a compact module that is based on a modified uni-travelling carrier (MUTC) photodetector chip. The VPDV2120 is not matched to 50  $\Omega$ . For applying a bias voltage of -6 V, an external bias-Tee is required. It has a responsivity of 0.55 A/W (1550 nm) and a high saturation photocurrent of 150 mA @ 10 GHz. The Ultra-high power PD is capable of delivering  $\geq 22$  dBm RF output power @ 10 GHz. The device exhibits a high linearity with typical OIP3 values above 30 dBm at a frequency of 10 GHz.

#### I Ordering Information

<b>VPDV2120-VF-FA</b>
-----------------------

VF = V connector, female  
FP = FC/PC connector  
FA = FC/APC connector

## II Block Diagram

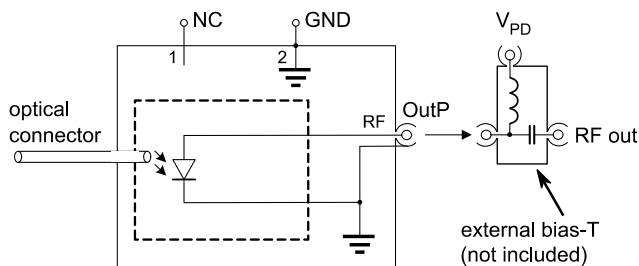

Figure 1: Block Diagram of VPDV2120

## III Absolute Maximum Ratings

Parameter	Symbol	Condition	Min.	Typ.	Max.	Unit
Photodiode bias voltage	V <sub>PD</sub>		-6.5		0	V
Average optical input power range	P <sub>OPT</sub>	continuous wave (CW)			27	dBm
Electro static discharge	V <sub>ESD</sub>	C=100 pF, R= 1.5 kΩ HBM	-250		250	V

## IV Environmental Conditions

Parameter	Symbol	Condition	Min.	Typ.	Max.	Unit
Storage temperature	T <sub>storage</sub>	non condensing	-40		+85	°C
Operating case temperature range	T <sub>case</sub>		0		+50	°C
Relative humidity range	RH	non condensing	5		85	%

## V Operating Conditions

Parameter	Symbol	Condition	Min.	Typ.	Max.	Unit
Operating wavelength range	λ		1520		1570	nm
Average optical input power range	P <sub>OPT</sub>				26	dBm
Photodiode bias voltage	V <sub>PD</sub>		-6	-5	-4	V

## VI Electro-Optical Specifications

Parameter	Symbol	Condition	Min.	Typ.	Max.	Unit
Photodiode DC responsivity	R	optimum polarization		0.55		A/W
Polarization dependent loss	PDL			0.1	0.3	dB
Optical return loss	ORL		30	40		dB
3dB cut-off frequency	f <sub>3dB</sub>	V <sub>PD</sub> = -5.0V, I <sub>PD</sub> = 100mA		11.5		GHz
RF output power	P <sub>out</sub>	10 GHz, V <sub>PD</sub> = -5.0V		22		dBm
Output 3 <sup>rd</sup> order intercept point	OIP3	10 GHz, V <sub>PD</sub> = -5.0V		25		dBm
Photodiode dark current	I <sub>dark</sub>	T <sub>case</sub> = 25°C		10	200	nA

## VII Typical Performance

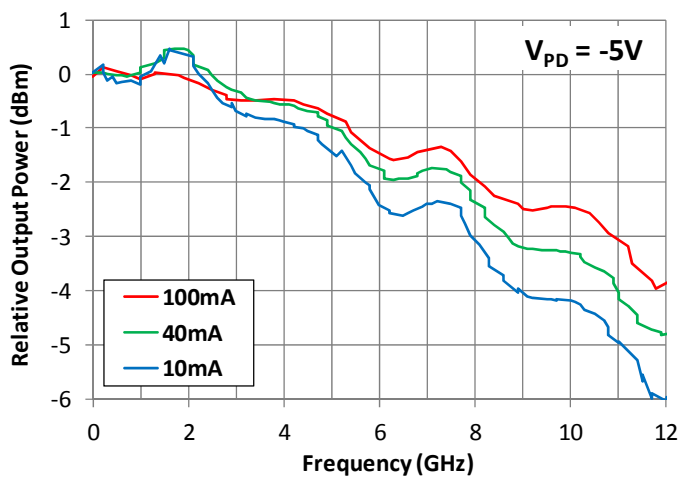

Figure 2: Frequency response of the VPDV2120 measured with a heterodyne signal

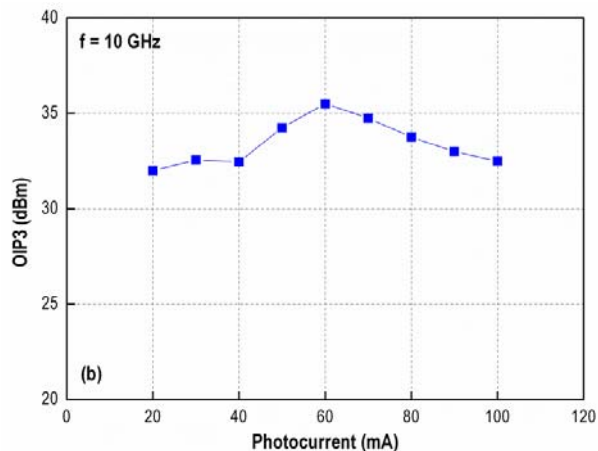

Figure 4: Output IP3 at a frequency of 10 GHz versus photocurrent.

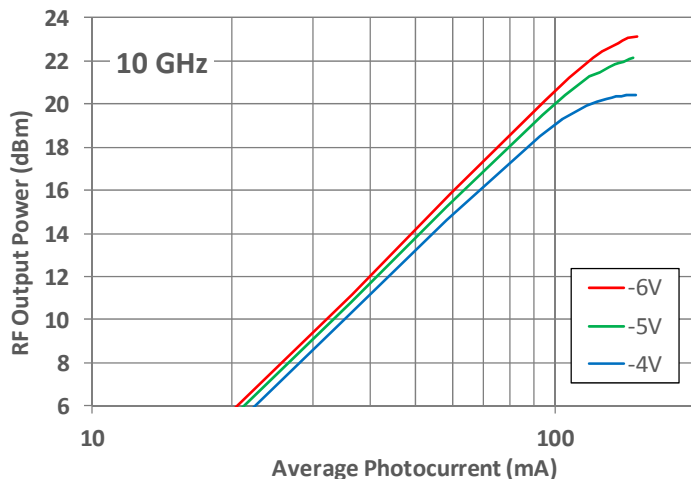

Figure 3: RF output power as a function of the photocurrent at a frequency of 10 GHz

## VIII Mechanical Specifications

All dimensions are in mm.

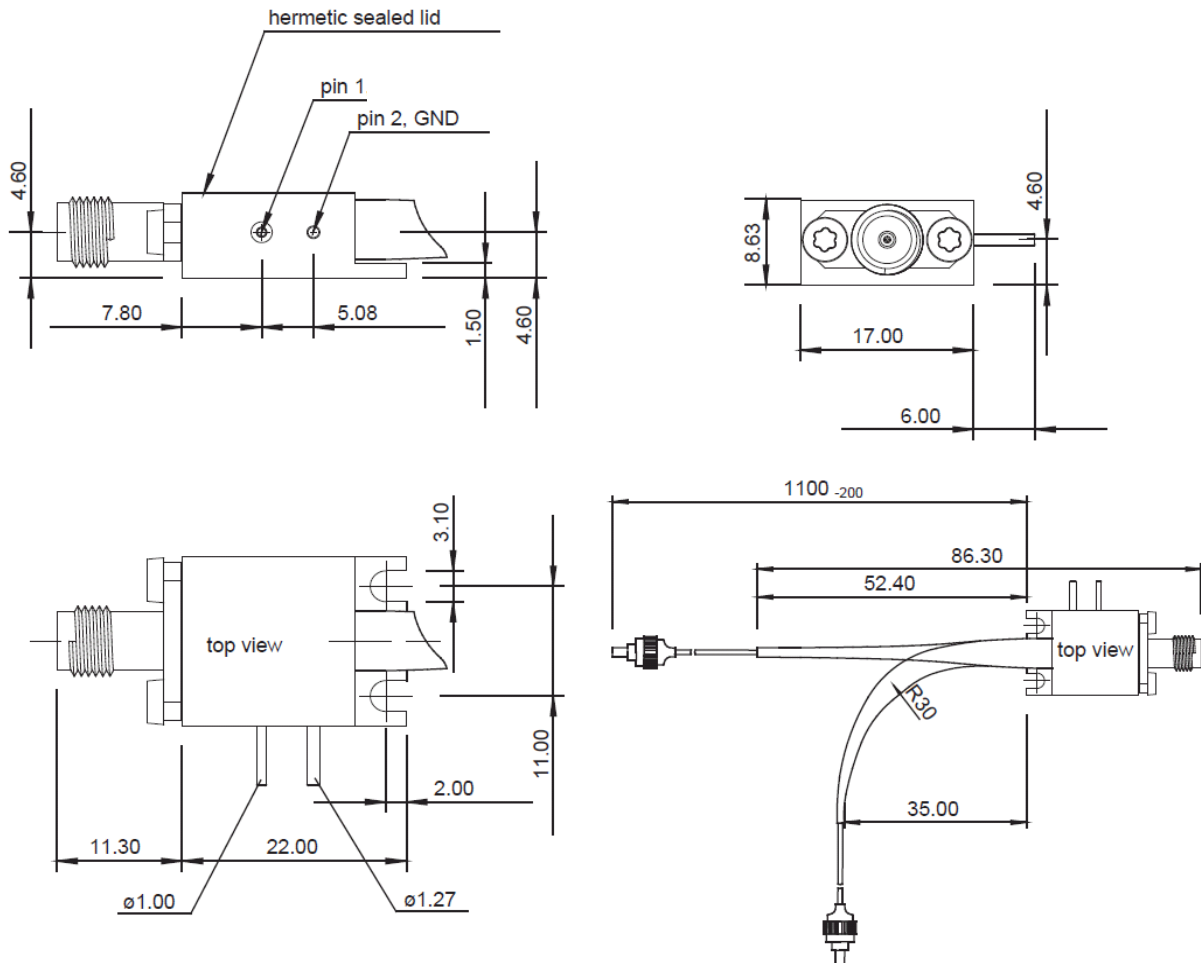

Figure 5: Mechanical dimensions of VPDV2120

## IX General Notices



**Class 1  
ESD sensitive device**  
according to TR-NWT-000870



### Notice

Stresses greater than those listed under “Absolute Maximum Ratings” may cause permanent damage to the device. This is a stress rating only and functional operation of the device at these or any other conditions above those indicated in the operations section for extended periods of time may affect reliability.

The inherent design of this component causes it to be sensitive to electrostatic discharge (ESD). To prevent ESD-induced damage and/or degradation to equipment, take normal ESD precautions when handling this product

## X Notes

Any trademarks used in this document are properties of their respective owners. Finisar Corporation reserves the right to make changes without notice.

## XI Revision History

Document Number: \_

Revision	Date	Description
A00	2016-10-14	Initial Release.
A02	2017-07-19	Updated parameters according to alpha samples

## XII For More Information

Finisar Corporation  
1389 Moffett Park Drive  
Sunnyvale, CA 94089-1133  
Tel: +1-408-548-1000  
Fax: +1-408-541-6138  
[high-speed-detectors@finisar.com](mailto:high-speed-detectors@finisar.com)  
[sales@finisar.com](mailto:sales@finisar.com)  
[www.finisar.com](http://www.finisar.com)