

spec ref	-	dr	Sunny2 Liu	2016/06/28	projection	MM	size	A2	scale	4:1	
tolerance std	ASME Y14.5	eng	Sunny2 Liu	2016/09/23			ecn no	-	rel level	Released	
TOLERANCES UNLESS OTHERWISE SPECIFIED		chr	Terris Liu	2016/09/23							
surface	linear	0.X	±0.50		product family		HPCE		title HPCE VT RECET 8LP20S OMITTED 2LP cat. no.	dwg no 10139839	rev A
		0.XX	±0.25		Product - Customer Drw		sheet 1 of 4				
	angular	0°	±2°		STATUS:Released		Printed: Sep 23, 2016				

CONTACT TYPE	TOP LAYER DESCRIPTION	TABLE 1 (HPCE / SOLDER TAILS) PLATED THROUGH-HOLE REQUIREMENTS				
		DRILLED HOLE DIAMETER	COPPER THICKNESS	TIN-LEAD THICKNESS	TIN THICKNESS	FINISHED HOLE DIAMETER(ØA)
POWER & SIGNAL	TIN-LEAD	1.10-1.16 (1.15 DRILL)	0.025 - 0.050	0.005 - 0.015	--	0.94 - 1.10
	IMMERSION TIN	1.10-1.16 (1.15 DRILL)	0.025 - 0.050	--	0.9 - 1.5um	0.94 - 1.10
	COPPER	1.10-1.16 (1.15 DRILL)	0.025 - 0.050	--	--	0.94 - 1.10

CONTACT TYPE	TOP LAYER DESCRIPTION	TABLE 2 (HPCE / PRESS-FIT TAILS) PLATED THROUGH-HOLE REQUIREMENTS				
		DRILLED HOLE DIAMETER	COPPER THICKNESS	TIN-LEAD THICKNESS	TIN THICKNESS	FINISHED HOLE DIAMETER(ØA)
POWER & SIGNAL	TIN-LEAD	0.81-0.86 (0.85 DRILL)	0.025 - 0.050	0.005 - 0.015	--	0.65 - 0.80
	IMMERSION TIN	0.81-0.86 (0.85 DRILL)	0.025 - 0.050	--	0.9 - 1.5um	0.70 - 0.80
	COPPER	0.81-0.86 (0.85 DRILL)	0.025 - 0.050	--	--	0.70 - 0.80

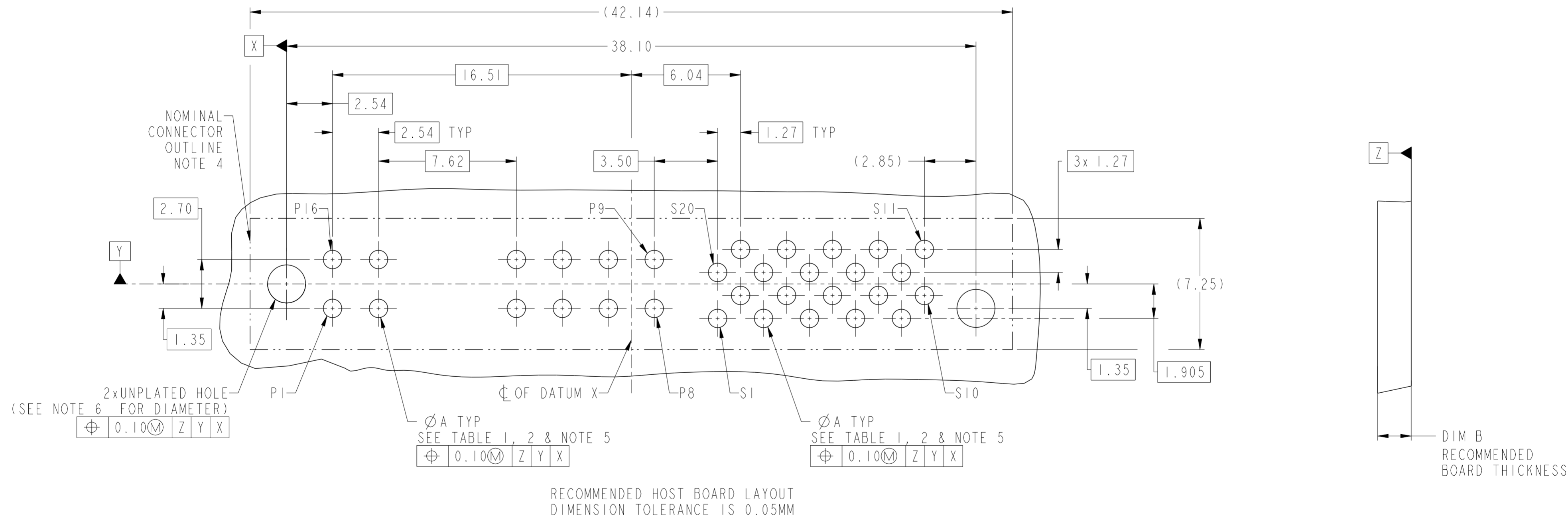

RECOMMENDED HOST BOARD LAYOUT  
DIMENSION TOLERANCE IS 0.05MM

Amphenol FCI

© 2016 AFCI

spec ref	-	dr	Sunny2 Liu	2016/06/28	projection	MM	size	A2	scale	1:1
tolerance std	ASME Y14.5	eng	Sunny2 Liu	2016/09/23			ecn no	-	rel level	Released
TOLERANCES UNLESS OTHERWISE SPECIFIED		chr	Terris Liu	2016/09/23						
surface		appr	Pei-Ming Zheng	2016/09/23						
linear	0.X ±0.50 0.XX ±0.25 0.XXX ±0.10	Amphenol FCI		HPCE VT RECET 8LP20S OMITTED 2LP		cat. no.	-	Product - Customer Drw	sheet 2 of 4	
angular	0° ±2°	Title		10139839		rev	A			

PDS: Rev :A

STATUS:Released

Printed: Sep 23, 2016

A

B

C

D

E

F

A

B

C

D

E

F

Amphenol  
FCi

© 2016 AFci

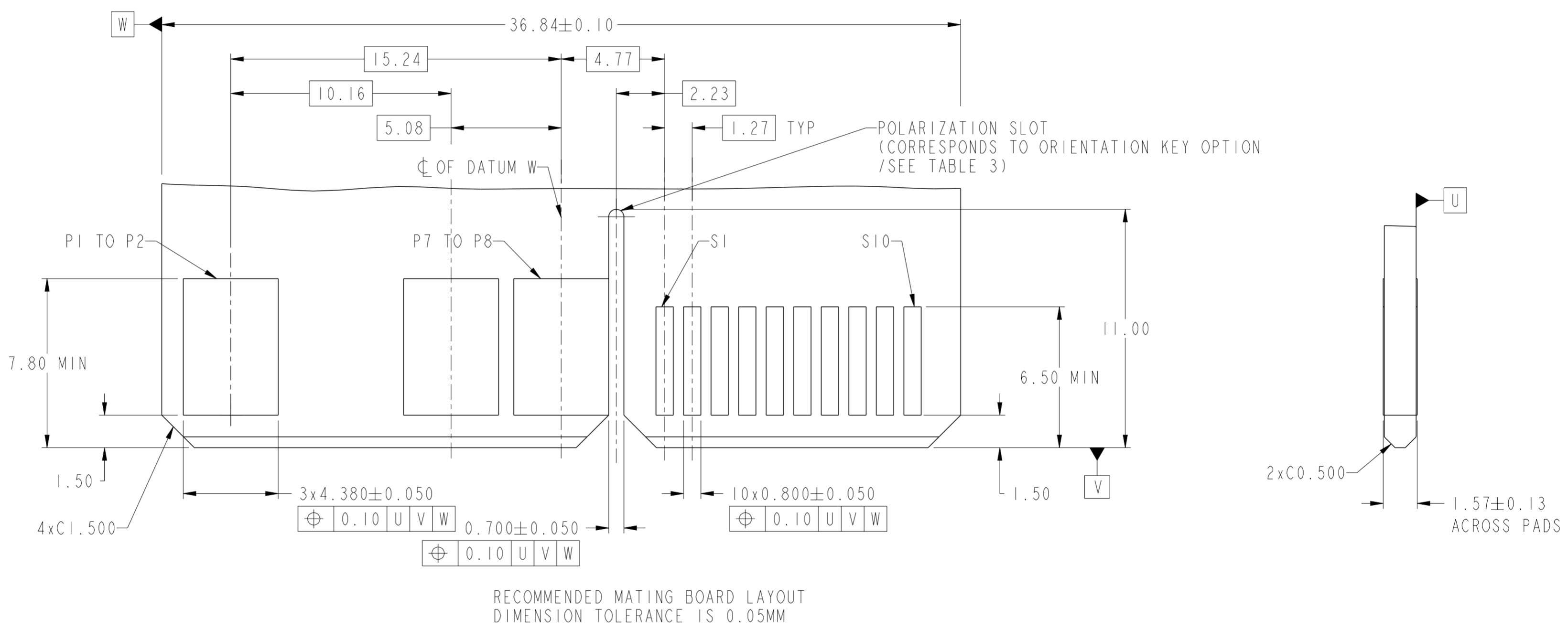

spec ref	-	dr	Sunny2 Liu	2016/06/28	projection	MM	size	A2	scale	1:1
tolerance std	ASME Y14.5	eng	Sunny2 Liu	2016/09/23			ecn no	-	rel level	Released
TOLERANCES UNLESS OTHERWISE SPECIFIED		chr	Terris Liu	2016/09/23						
surface	linear	0.X	±0.50		HPCE VT RECET 8LP20S OMITTED 2LP	cat. no.	Product - Customer Drw	sheet 3 of 4	rev A	
		0.XX	±0.25							
		0.XXX	±0.10							
	angular	0°	±2°							

PDS: Rev :A

STATUS:Released

Printed: Sep 23, 2016

HPCE PART NUMBER (TABLE 3)

PART NUMBER	TAIL TYPE	ORIENTATION KEY	TAIL LENGTH	DIM B RECOMMENDED BOARD THICKNESS
10139839-001LF	SOLDER	YES	3.17 ±0.25	2.36±0.13
10139839-002LF		NO		
10139839-003LF	PRESS FIT	YES		1.57 MIN
10139839-004LF		NO		

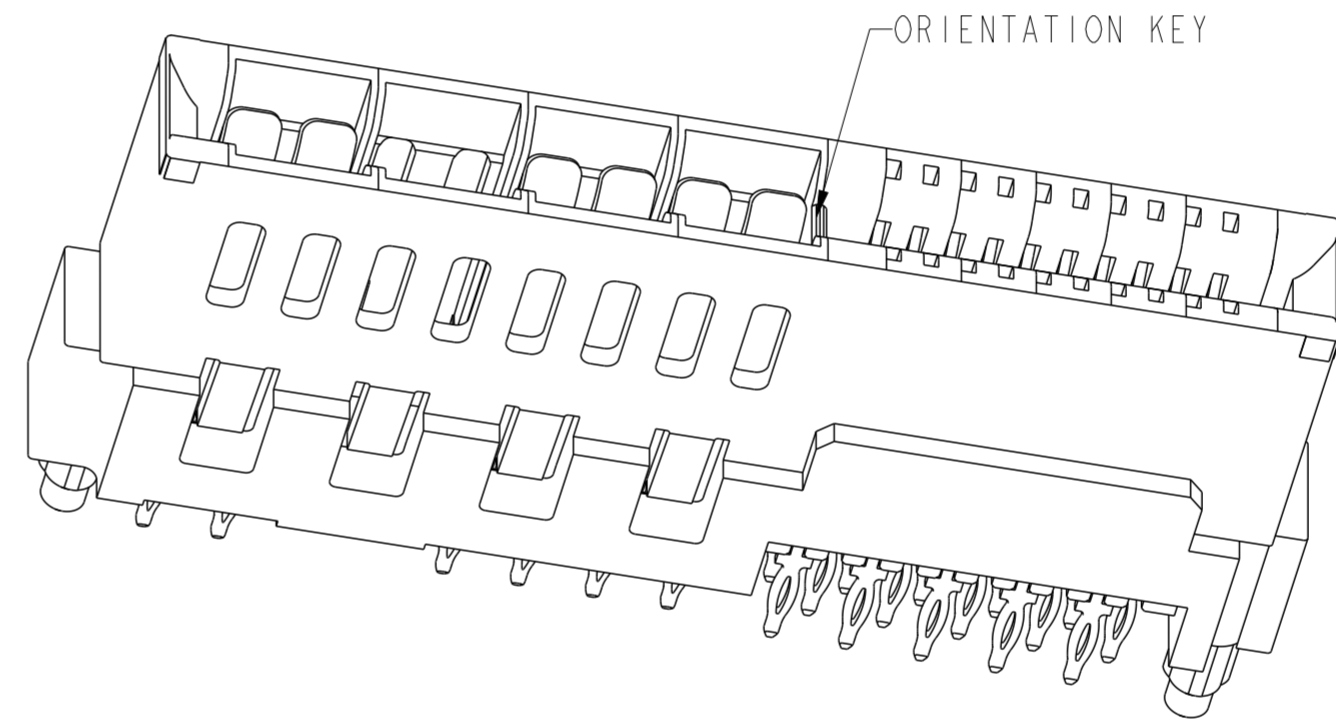

NOTES:

- 1) PRODUCT MARK:  
PART NUMBER AND DATE CODE TO BE MARKED ON THIS SURFACE .  
THE MARK CAN BE OMITTED IF THERE IS NOT ENOUGH SPACE ON THIS SURFACE.
- 2) MATERIALS:  
-HOUSING : HIGH TEMPERATURE THERMOPLASTIC WITH GLASS FIBER, UL94V-0, BLACK.  
-CONTACT : COPPER ALLOY.
- 3) CONTACT FINISH REF: GS-12-604 SECTION 5.2.
- 4) DENOTES CONNECTOR KEEP OUT ZONE.
- 5) ALL HOLE DIAMETERS ARE FINISHED HOLE SIZES.
- 6) MOUNTING HOLES ARE UNPLATED  
 $\varnothing 2.18 \pm 0.03$  FOR SOLDER TAILS  
 $\varnothing 2.40 \pm 0.1$  FOR PRESS FIT TAILS
- 7) THE HOUSING WILL WITHSTAND EXPOSURE TO 245°C PEAK TEMPERATURE FOR 10 SECONDS IN A WAVE SOLDER PROCESS.
- 8) THIS PRODUCT MEETS EUROPEAN UNION DIRECTIVES AND OTHER COUNTRY REGULATIONS AS DESCRIBED IN GS-47-0004.
- 9) PRODUCT SPECIFICATION : GS-12-604.  
APPLICATION SPECIFICATION : GS-20-128.  
PACKAGING SPECIFICATION: GS-14-937.
- 10) PRESS FIT APPLICATION TOOL DRAWING:10119453.

spec ref	-	dr	Sunny2 Liu	2016/06/28	projection	MM	size	A2	scale	4:1												
tolerance std	-	eng	Sunny2 Liu	2016/09/23			ecn no	-	rel level	Released												
ASME Y14.5	TOLERANCES UNLESS OTHERWISE SPECIFIED	chr	Terris Liu	2016/09/23																		
surface	<table border="1"> <tr> <td>linear</td> <td>0.X</td> <td>±0.50</td> </tr> <tr> <td></td> <td>0.XX</td> <td>±0.25</td> </tr> <tr> <td></td> <td>0.XXX</td> <td>±0.10</td> </tr> <tr> <td>angular</td> <td>0°</td> <td>±2°</td> </tr> </table>	linear	0.X	±0.50		0.XX	±0.25		0.XXX	±0.10	angular	0°	±2°	appr	Pei-Ming Zheng	2016/09/23	product family	HPCE	cat. no.	-	Product - Customer Drw	sheet 4 of 4
linear	0.X	±0.50																				
	0.XX	±0.25																				
	0.XXX	±0.10																				
angular	0°	±2°																				
ASME Y14.5		Amphenol FCI	title	HPCE VT RECET 8LP20S OMITTED 2LP	dwg no	10139839	rev	A														