

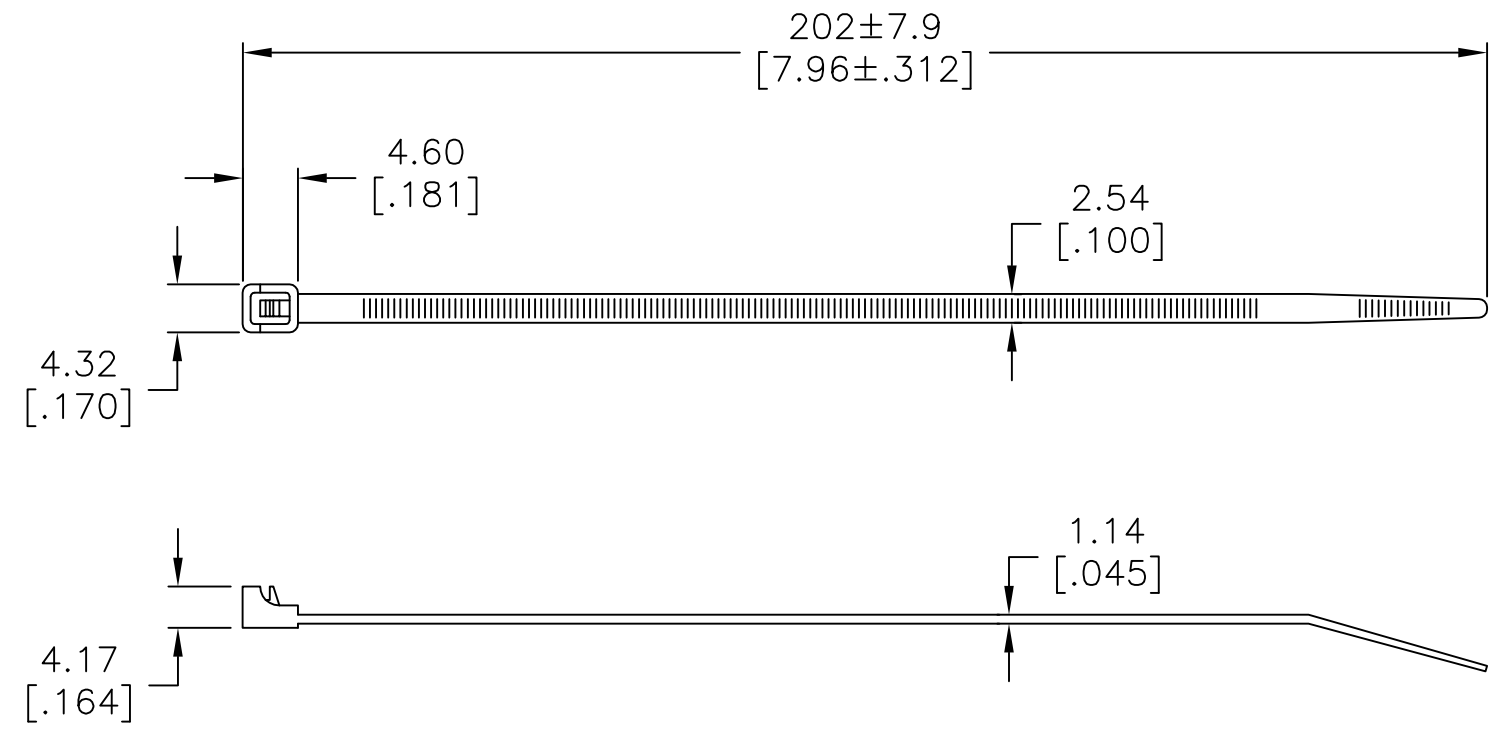

THIS DRAWING IS UNPUBLISHED. RELEASED FOR PUBLICATION
 © COPYRIGHT - By - ALL RIGHTS RESERVED.

REVISIONS					
P	LTR	DESCRIPTION	DATE	DWN	APVD
	G2	REVISED PER ECO-13-004228	08JUN13	KH	DR
	G3	REVISED PER ECO-17-014337	06OCT2017	RS	DR

- 1 PACKAGED IN A HEAT SEALED 3 MIL POLYBAG.
- 2 MAXIMUM BUNDLE DIAMETER: $\phi 50.8$ [$\phi 2.0$].
- 3 MINIMUM TENSILE STRENGTH: 8.165 KG [18 LBS].
- 4 MEETS MIL NO. MS3367-4 REQUIREMENTS.

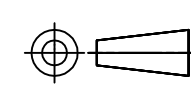

1000	BLACK	2-608687-0
1000	NATURAL	2-608687-9
100	BLACK	1-608687-0
100	NATURAL	1-608687-9
QUANTITY/BAG	COLOR	PART NUMBER

THIS DRAWING IS A CONTROLLED DOCUMENT.		DWN JR RUTH 12MAR10	 TE Connectivity NAME CABLE TIE, RELEASABLE, 8 INCHES				
DIMENSIONS: mm [INCHES]		CHK T MICHELUTTI 12MAR10				APVD T MICHELUTTI 12MAR10	RESTRICTED TO
		PRODUCT SPEC				SIZE	
TOLERANCES UNLESS OTHERWISE SPECIFIED:		APPLICATION SPEC				CAGE CODE	
MATERIAL NYLON 6/6		FINISH -		WEIGHT -	DRAWING NO A3 00779 C-608687		
		CUSTOMER DRAWING		SCALE NONE	SHEET 1 OF 1		
				REV G3			