

APPROVAL SHEET

WW18X

±1%, ±5%

Low ohmic power chip resistors

Size 1218

Customer : _____

Approval No : _____

Issue Date : _____

Customer Approval :



FEATURE

1. High power rating and compact size
2. High reliability and stability
3. Reduced size of final equipment
4. Lead free termination upon customer requested

APPLICATION

- Power supply
- PDA
- Digital meter
- Computer
- Automotives
- Battery charger
- DC-DC power converter

DESCRIPTION

The resistors are constructed in a high grade ceramic body (aluminum oxide). Internal metal electrodes are added at each end and connected by a resistive paste that is applied to the top surface of the substrate. The composition of the paste is adjusted to give the approximate resistance required and the value is trimmed to nominated value within tolerance which controlled by laser trimming of this resistive layer.

The resistive layer is covered with a protective coat. Finally, the two external end terminations are added. For ease of soldering the outer layer of these end terminations is a Lead-tin or Tin (lead free) alloy.

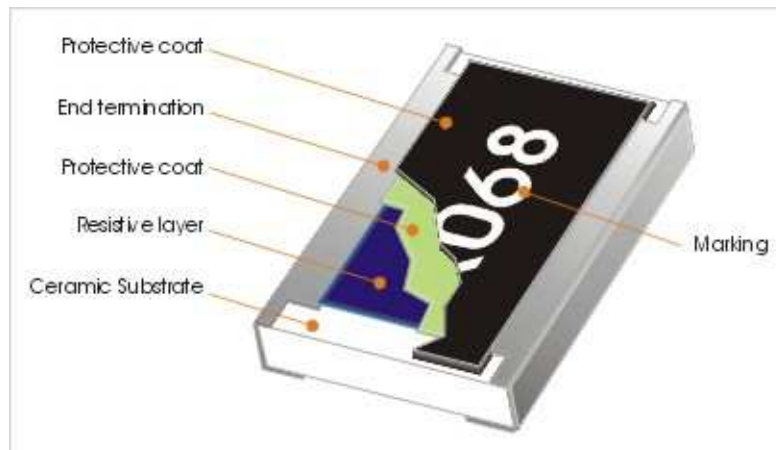

Fig 1. Construction of a 1218 Chip-R

**QUICK REFERENCE DATA**

Item	General Specification	
Series No.	WW18X	
Size code	1218(3248)	
Resistance Tolerance	±5% (E24)	±1% (E96)
Resistance Range	0.02Ω ~ 0.91Ω	0.02Ω ~ 0.976Ω
TCR (ppm/°C)		
0.02Ω ≤ Rn < 0.05Ω	≤ 1500 ppm/°C	
0.05Ω ≤ Rn < 0.10Ω	≤ 1000 ppm/°C	
0.10Ω ≤ Rn < 0.50Ω	≤ 500 ppm/°C	
0.50Ω ≤ Rn < 1Ω	≤ 300 ppm/°C	
Max. dissipation at T _{amb} =70°C	1 W	
Max. Operation Voltage (DC or RMS)	200V	
Climatic category (IEC 60068)	55/155/56	

Note :

1. This is the maximum voltage that may be continuously supplied to the resistor element, see "IEC publication 60115-8"
2. Max. Operation Voltage : So called RCWV (Rated Continuous Working Voltage) is determined by

$$RCWV = \sqrt{\text{Rated Power} \times \text{Resistance Value}}$$
or Max. RCWV listed above, whichever is lower.
3. Tolerance of TCR=±200ppm/°C
4. Resistance value will be changed by soldering condition and design of soldering pad, please design products in consideration of this change of resistance value.

MECHANICAL DATA

Symbol	Dimensions (mm)
L	3.05±0.15
W	4.60±0.20
T	0.55±0.10
Tt	0.45±0.25
Tb	0.50±0.25

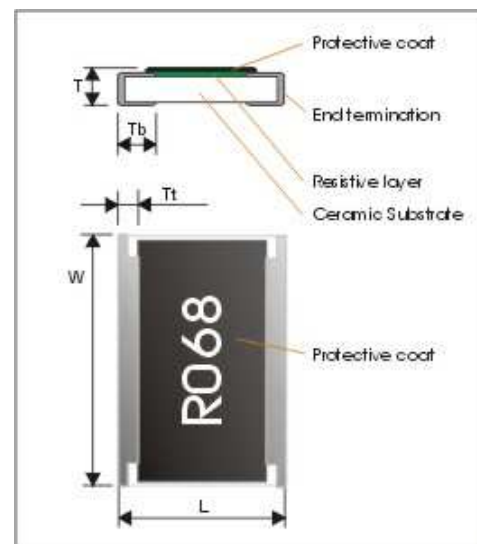
**MARKING**

Each resistor is marked with a four-digit code on the protective coating to designate the nominal resistance value.

Example:

$$R010 = 0.01\Omega, R510 = 0.51\Omega$$



FUNCTIONAL DESCRIPTION

Product characterization

Standard values of nominal resistance are taken from the E96 & E24 series for resistors with a tolerance of $\pm 5\%$ & $\pm 1\%$. The values of the E24/E96 series are in accordance with "IEC publication 60063".

Derating curve

The power that the resistor can dissipate depends on the operating temperature; see Fig.2

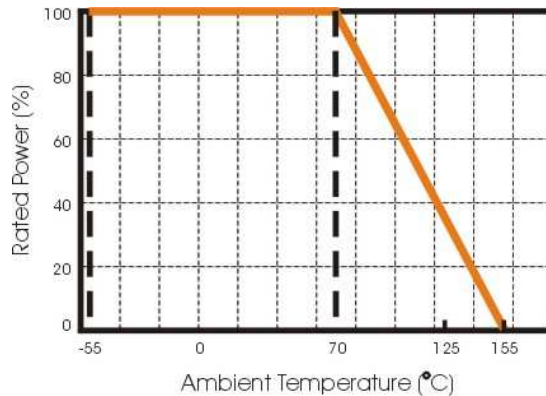

Fig.2 Maximum dissipation in percentage of rated power As a function of the ambient temperature

MOUNTING

Due to their rectangular shapes and small tolerances, Surface Mountable Resistors are suitable for handling by automatic placement systems.

Chip placement can be on ceramic substrates and printed-circuit boards (PCBs).

Electrical connection to the circuit is by individual soldering condition.

The end terminations guarantee a reliable contact.

SOLDERING CONDITION

The robust construction of chip resistors allows them to be completely immersed in a solder bath of 260°C for 10 seconds. Therefore, it is possible to mount Surface Mount Resistors on one side of a PCB and other discrete components on the reverse (mixed PCBs).

Surface Mount Resistors are tested for solderability at 245°C during 3 seconds. The test condition for no leaching is 260°C for 30 seconds. Typical examples of soldering processes that provide reliable joints without any damage are given in Fig 3.

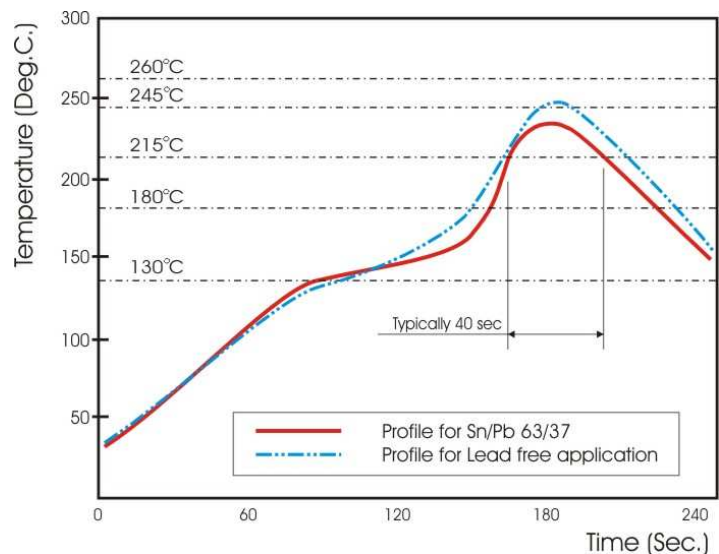

Fig 3. Infrared soldering profile for Chip Resistors WW18X

CATALOGUE NUMBERS

The resistors have a catalogue number starting with .

WW18	X	R100	J	T	L
Size code WW18: 1218	Type code X : Thick film,	Resistance code – 4 digits R100 = 0.1 OHM R976 = 0.976 OHM	Tolerance J: $\pm 5\%$ F: $\pm 1\%$	Packaging code T: 10" Reeled taping	Termination code L = Sn base (lead free)

- Reeled tape packaging : paper taping 3000pcs per 10" reel.

TEST AND REQUIREMENTS(JIS C 5201-1 : 1998)

Essentially all tests are carried out according to the schedule of IEC publication 115-8, category **LCT/UCT/56**(rated temperature range : **L**ower **C**ategory **T**emperature, **U**pper **C**ategory **T**emperature; damp heat, long term, 56 days). The testing also meets the requirements specified by EIA, EIAJ and JIS.

The tests are carried out in accordance with IEC publication 68, "Recommended basic climatic and mechanical robustness testing procedure for electronic components" and under standard atmospheric conditions according to IEC 60068-1, subclause 5.3. Unless otherwise specified, the following value supplied :

Temperature: 15°C to 35°C.

Relative humidity: 45% to 75%.

Air pressure: 86kPa to 106 kPa (860 mbar to 1060 mbar).

All soldering tests are performed with mildly activated flux.

TEST	PROCEDURE	REQUIREMENT
Temperature Coefficient of Resistance(T.C.R) Clause 4.8	Natural resistance change per change in degree centigrade. $\frac{R_2 - R_1}{R_1(t_2 - t_1)} \times 10^6 \text{ (ppm/}^\circ\text{C)}$ $t_1 : 20^\circ\text{C}+5^\circ\text{C}-1^\circ\text{C}$ R ₁ : Resistance at reference temperature R ₂ : Resistance at test temperature	Refer to "QUICK REFERENCE DATA"
Short time overload (S.T.O.L) Clause 4.13	Permanent resistance change after a 5second application of a voltage 2.5 times RCWV or the maximum overload voltage specified in the above list, whichever is less.	ΔR/R max. ±(2%+0.005Ω)
Resistance to soldering heat(R.S.H) IEC 60068-2-58: 2004	Un-mounted chips completely immersed for 10±1second in a SAC solder bath at 255°C ±5°C	no visible damage Δ R/R max. ±(1%+0.005Ω)
Solderability IEC 60068-2-58: 2004	Un-mounted chips completely immersed for 3±0.3second in a SAC solder bath at 245°C ±5°C	good tinning (>95% covered) no visible damage
Temperature cycling Clause 4.19	30 minutes at -55°C±3°C, 2~3 minutes at 20°C+5°C-1°C, 30 minutes at +155°C±3°C, 2~3 minutes at 20°C+5°C-1°C, total 5 continuous cycles	no visible damage ΔR/R max. ±(1%+0.005Ω)
Load life (endurance) Clause 4.25	1000 +48/-0 hours, loaded with RCWV or Vmax in chamber controller 70±2°C, 1.5 hours on and 0.5 hours off	ΔR/R max. ±(3%+0.005Ω)
Load life in Humidity Clause 4.24	1000 +48/-0 hours, loaded with RCWV or Vmax in humidity chamber controller at 40°C±2°C and 90~95% relative humidity, 1.5hours on and 0.5 hours off	ΔR/R max. ±(3%+0.005Ω)
Bending strength Clause 4.33	Resistors mounted on a 90mm glass epoxy resin PCB(FR4); bending : 2 mm, once for 10 seconds	ΔR/R max. ±(1%+0.005Ω)
Adhesion Clause 4.32	Pressurizing force: 5N, Test time: 10±1sec.	No remarkable damage or removal of the terminations
Insulation Resistance JISC5201-1:1998 Clause 4.6	Apply the maximum overload voltage (DC) for 1minutes	R ≥ 10GΩ
Dielectric Withstand Voltage JISC5201-1:1998 Clause 4.7	Apply the maximum overload voltage (AC) for 1 minutes	No breakdown or flashover



PACKAGING

Plastic Tape specifications (unit :mm)

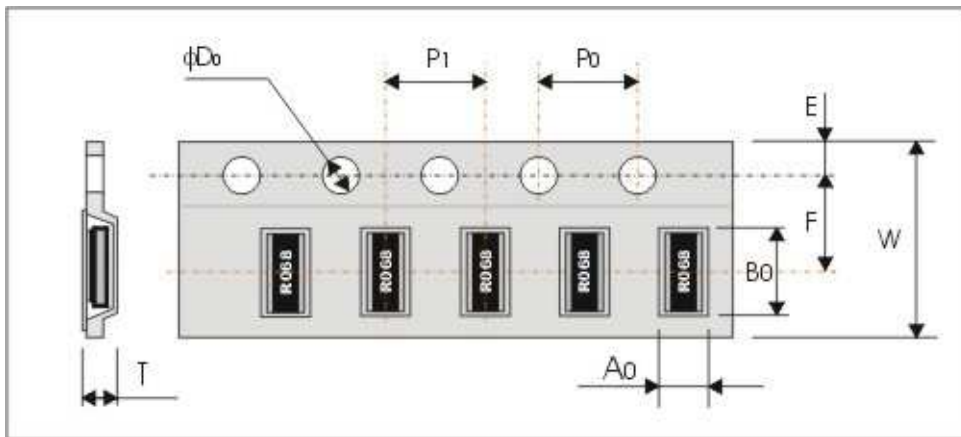

Symbol	A_0	B_0	W	F	E
Dimensions	3.55 ± 0.30	4.90 ± 0.20	12.00 ± 0.20	5.50 ± 0.05	1.75 ± 0.10

Symbol	P_1	P_0	ϕD	T
Dimensions	8.00 ± 0.10	8.00 ± 0.10	$\phi 1.55^{+0.1}_{-0.0}$	1.30 ± 0.20

Reel dimensions

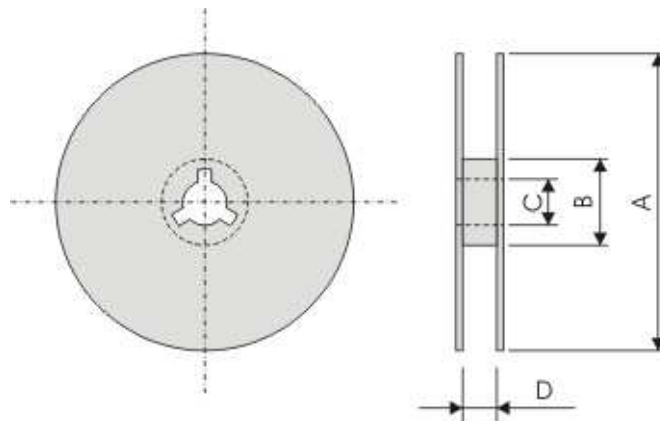

Symbol	A	B	C	D
(unit : mm)	$\phi 178.0 \pm 2.0$	$\phi 60.0 \pm 1.0$	13.0 ± 0.2	14.0 ± 0.2

Taping quantity

- Chip resistors 3,000 pcs per reel.